

IoT Online Energy Monitoring Cloud Solution

IoT based, Online Energy Monitoring, 4G/WiFi Cloud based, 1-phase&3-phase

Ver. Date: July,6th 2023

Acrel Co., Ltd.

No.253 Yulv Road, Jiading
District, Shanghai, China



0. Application Scenario

(1) A typical building power system is a comprehensive system consisted of 3-phase & 1-phase power system. And 3-phase & 1-phase system are obviously consisted of the 3-phase & 1-phase circuits. And all the loads in this building are powered by all these circuits. Thus, the aim of Building Online Energy Monitoring for all the monitoring loads in a certain building was to first confirm and all the 3-phase & 1-phase circuits' monitoring point and deploy compatible energy meter and paired CTs if requested on them for energy monitoring. And then select compatible IoT gateway or Wireless energy meter for data uploading to a Online IoT Energy Monitoring System.

(2) The key of whether select the combination for IoT Gateway + Energy Meter or Wireless Energy Meter, was whether the energy meter could be of **centralized installation** or **separate installation**. This will decide which plan will be more economic and convenient to deploy.

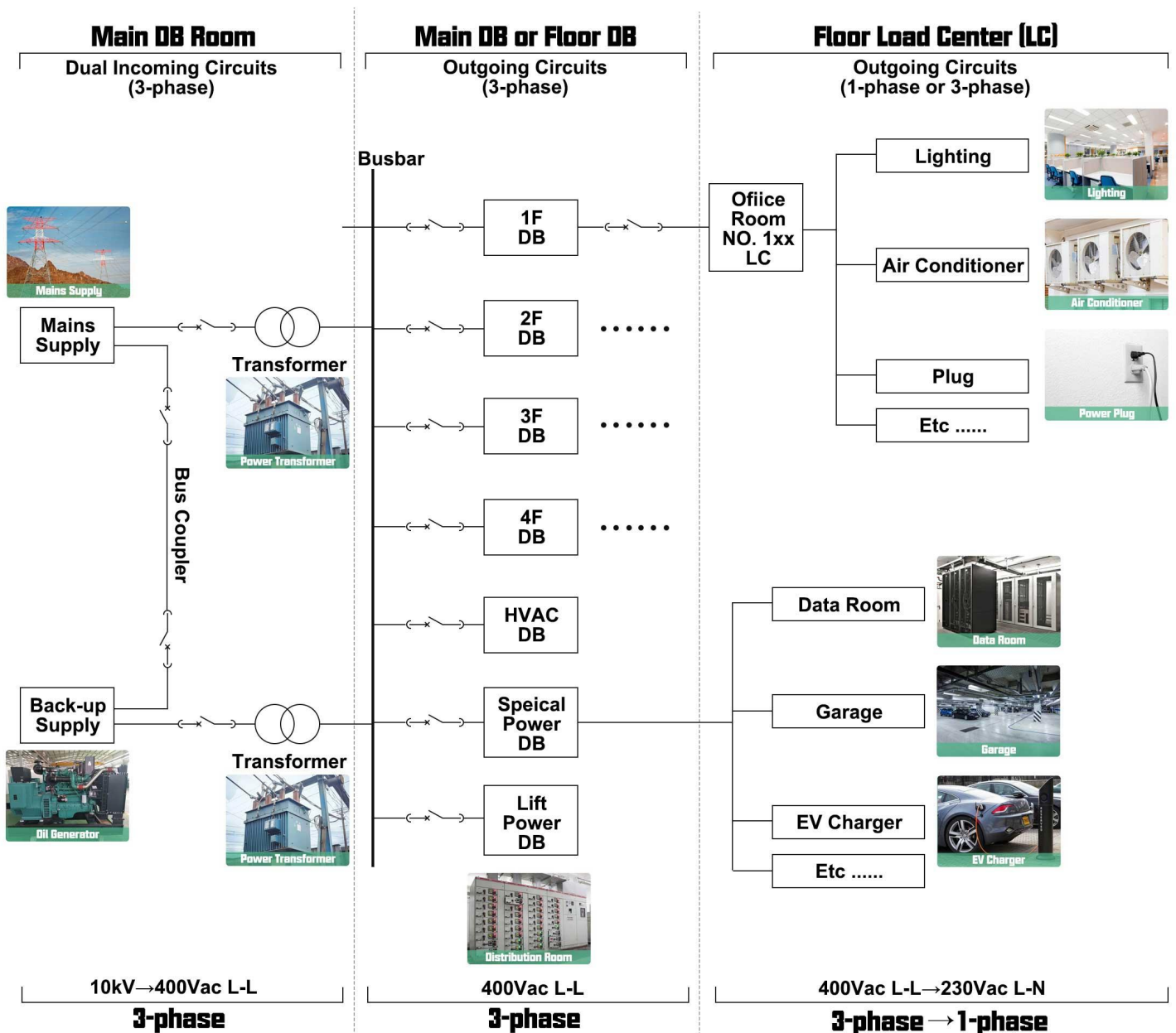

0. Basic Solution Selection Logic

Three key factor will influence our solution on dicisionng of hardware module selection.

- (1) **Type** of monitoring circuit. [Either **1-phase** or **3-phase** monitoring circuit]
- (2) **Centralized** monitoring or **separate** monitoring [Energy meter will be of **centralized** or **separate** installation]
- (3) **Network Comms.** which more stable and convenient to acquire. [**4G** or **WiFi**]

And judging by these 3 factor, there will be **9** basic solution branches in total for guiding us to use the compatible solutions for the different situation of Building Online Energy Monitoring:

- 3-phase, Centralized, 4G based Solution [3-phase Energy Meter plus 4G Gateway Plan]
- 3-phase, Centralized, WiFi based Solution [3-phase Energy Meter plus WiFi Gateway Plan]
- 3-phase, Separate,4G based Solution [3-phase 4G Wireless Energy Meter Plan]
- 3-phase, Separate, WiFi based Solution [3-phase WiFi Wireless Energy Meter Plan]
- 1-phase, Centralized, 4G based Solution [1-phase Energy Meter plus 4G Gateway Plan]
- 1-phase, Centralized, WiFi based Solution [1-phase Energy Meter plus WiFi Gateway Plan]
- 1-phase, Separate,4G based Solution [1-phase 4G Wireless Energy Meter Plan]
- 1-phase, Separate, WiFi based Solution [1-phase WiFi Wireless Energy Meter Plan]

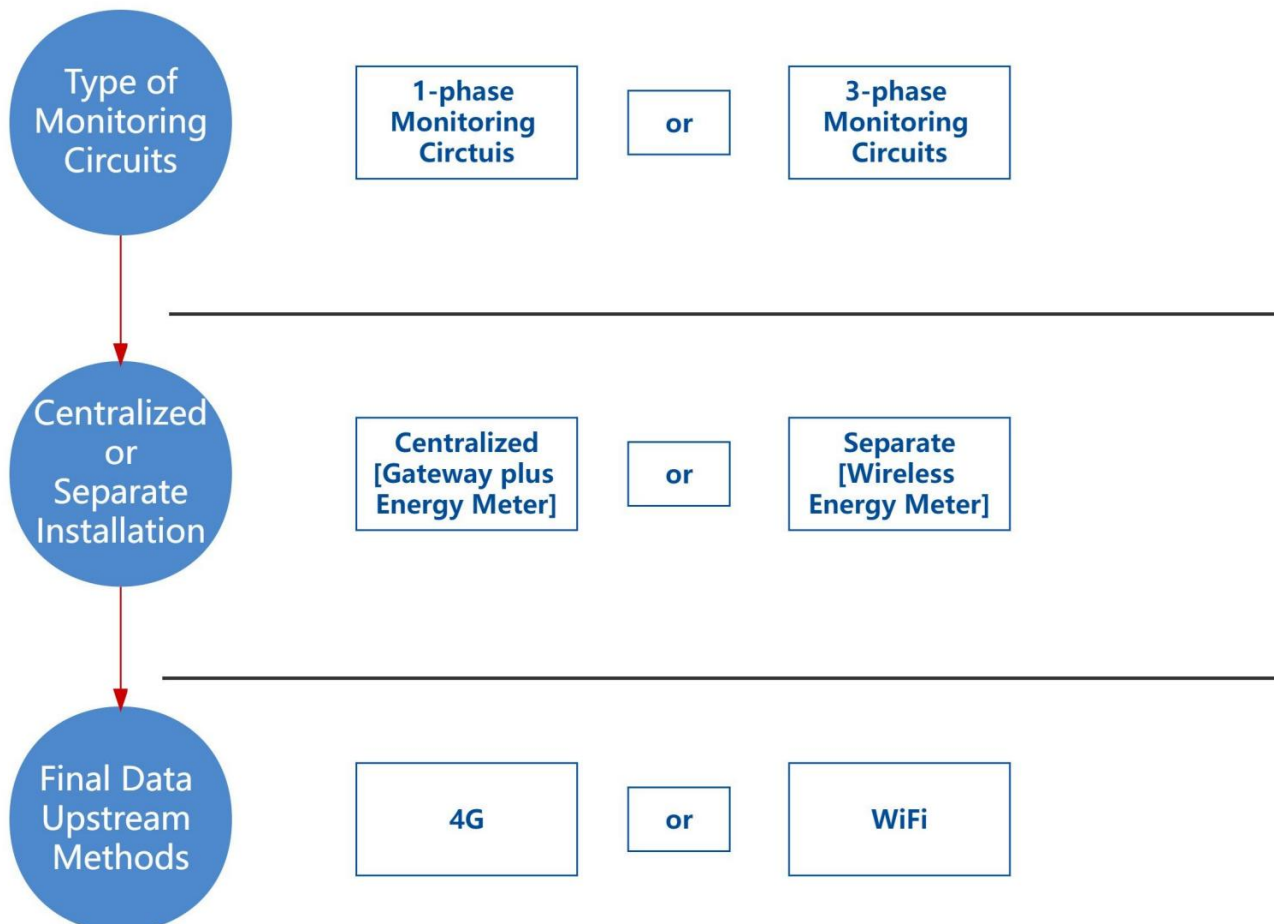

1. Scenario Preset [3-phase, Centralized, 4G based Solution]

- (1) There are 10 Areas with 3-phase Power System needed to be monitored
- (2) Each area has 20 circuits 3-phase needed to be monitored, circuits' rated voltage is 3x400Vac L-L and 3x230Vac L-N, circuit's rated current is 100A AC.
- (3) For the place that we gonna install energy meter and 4G gateway, it was covered by stable 4G signal.
- (4) All 3-phase energy meter will be of partial centralized installation in each area, which make it possible for 1 AWT100-4GHW 4G IoT gateway to support 20 (max 25, recommend 20) ADL400/C 3-phase Energy Meters using RS485 wired communication in a close range within 300m.

2. Devices Deployment Plan [3-phase, Centralized, 4G based Solution]

Area #1 - Power Circuit [3-phase] #1-1 ~ #1-20:

- 1* AWT100-4GHW IoT 4G Gateway [Support energy meter in Area #1 for 4G Data Upstream]
- 1* AWT100-POW Power Supply Module [For 85~265Vac/Vdc power supply of AWT100-4GHW]
- 20* ADL400/C 3-phase DIN-rail Energy Meter [For monitoring Power Circuit #1-1 ~ #1-20]
- 60* AKH-0.66/K K- 24 150/5 Split-core Current Transformer [Paired with ADL400/C for current input]

Area #10 - Power Circuit [3-phase] #10-1 ~ #10-20:

- 1* AWT100-4GHW IoT 4G Gateway [Support energy meter in Area #10 for 4G Data Upstream]
- 1* AWT100-POW Power Supply Module [For 85~265Vac/Vdc power supply of AWT100-4GHW]
- 20* ADL400/C 3-phase DIN-rail Energy Meter [For monitoring Power Circuit #10-1 ~ #10-20]
- 60* AKH-0.66/K K- 24 150/5 Split-core Current Transformer [Paired with ADL400/C for current input]

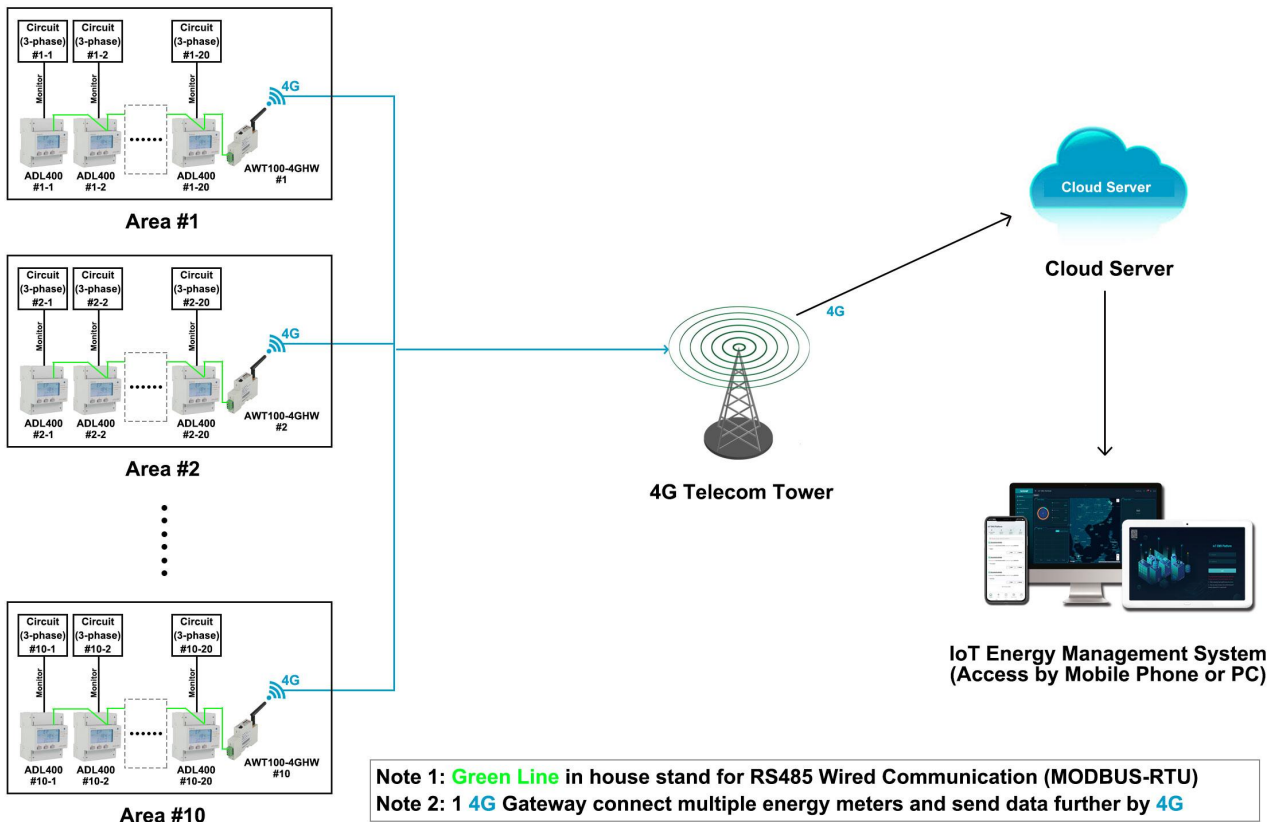

2. Communication Structure&Logic - [3-phase, Centralized, 4G based Solution]

- (1) 4G Communication could be served as one of the final data upstream methods by sending the data to cloud server deployed in Internet so that Acrel IoT System could be interact with these data collected by bottom metering devices like Energy Meter
- (2) AWT100-4GHW gateway support upstream of 4G communication with MQTT and MODBUS-TCP protocol and downstream of RS485 communication based on MODBUS-RTU protocol. ADL400/C support upstream communication of RS485 communication based on MODBUS-RTU protocol.
- (3) Based on the communication described in item (2), Acrel AWT100-4GHW gateway could receive the data from ADL400/C energy meter using RS485 communication while sending the data further to cloud server using 4G upstream communication. Thus accomplish a complete communication from bottom metering devices to top system software.

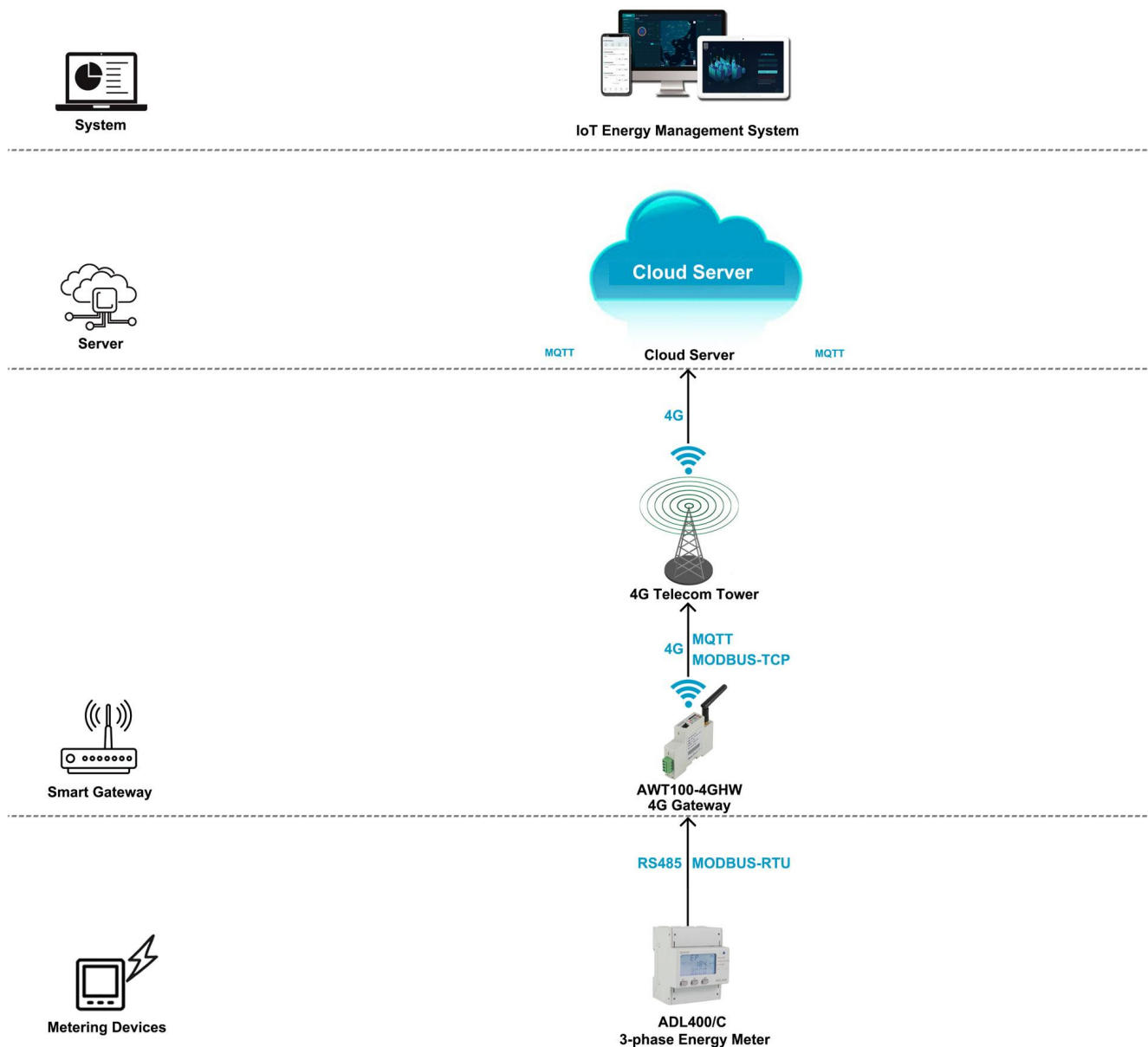

4. Hardware Devices Overview - [3-phase, Centralized, 4G based Solution]

Model 1: AWT1000-4GHW IoT 4G Smart Gateway

- Upstream Comms.: 4G LTE [MQTT, MODBUS Protocol]
- Downstream Comms.: RS485 [MODBUS-RTU Protocol]
- Support: Up to 25 Downstream Devices via RS485.
- Auxiliary Power Supply: 85~265Vac [via AWT100-POW]
- Certificate&Standard: CE; CE-RED; IEC

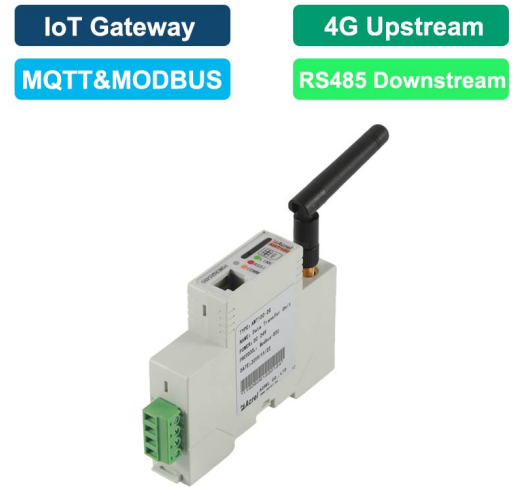

Model 2: AWT100-POW Power Supply Module

- Input: 85~265Vac
- Output: 12Vdc
- Application: Paired with AWT100-4GHW for 85~265Vac Power Supply Input [via PIN L & PIN N]
- Certificate&Standard: CE

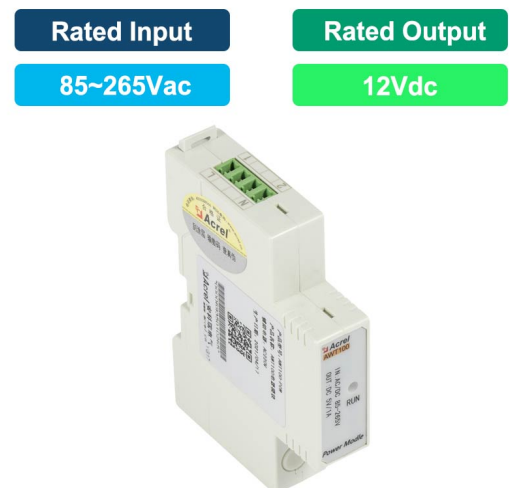

Model 2: ADL400 3-phase AC DIN-rail Energy Meter

- Monitoring: Up 1 circuits 3-phase [AC Metering]
- Rated Voltage: 3x380~456Vac L-L & 220~264Vac L-N
- Rated Current: 3x1(6)A AC (via paired CT)
- Wired Comms: RS485 Interface, MODBUS-RTU Protocol
- Certificate&Standard: CE; CE-MID; EAC



3. Hardware Devices Overview - [3-phase, Centralized, 4G based Solution]

Model 2: AKH-0.66/K K- 24 150/5 Split-core Current Transformer

- Current Ratio: 150A/5A
- Primary Current: 150A
- Secondary Current: 5A
- Accuracy: Class 0.5 or 1.0
- Certificate&Standard: CE

AC

Split Core





60~400A

Class 0.5

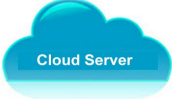

4. Overall Model Selection&Quotation - [3-phase, Centralized, 4G based Solution]

(1) This Quotation doesn't include freight charge. To gain a complete quotation, please refer the actual quantity that you want to request for the actual order, once we receiving it. We will issue a Official Proforma Invoice with Acrel Stamps on it for later procedure.

System Software					
Name	Description	System Price	Remark (Choose Host Service or Buy-out Service after 3-month Free Trial of Cloud IoT System)		
 Acrel Cloud IoT Energy Management System	1.System support all the meters across the country whose data has been sent to cloud server through 4G,WiFi or Ethernet . 2.Remote meter reading and data collection. 3.Provide IoT APP for mobile phone side and IoT WEB for PC side. 4.Generate energy data report of daily, monthly and annually period with year-on-yeay and period-on-period energy analysis. 5.Provide various alarm function to ensure a stable operation of the system and protect your property. 6.Offer 3-month free trial of system with full technical support as for a test phase or pilot project.	\$0 (recommended in pilot project)	3-month Free Trail (Users don't need to rent a cloud server)		
		\$xxxx/Year (For 200 Points) (Price for Host Service Only, recommended in pilot project)	\$xx to buy Hosting Service for 1 monitoring points connected to the system 1 year (Users don't need to rent a cloud server)		
		\$xxxxPermanent (Limitless Points) (Price for Buy-out Service Only,recommended in late project)	1-time charging of \$xxxx for Buy-out Service of permanent use (Limitless monitoring points and a cloud server need to be rent by users)		
Cloud Server					
Name	Description	Server Renting Price (For Reference Only)	Remark		
 Cloud Server	1.Cloud Server could be rent on the cloud server provider like Amazon Cloud. 2.Users of Cloud IoT Energy Management System only need to rent cloud server when they choose buy-out service of our Cloud IoT System . And if they are using hosting service or 3-month free trial of our Cloud IoT System , we will use our own cloud server which has been rent on Amazon so that users don't need to rent a cloud server. 3.The quotation of Cloud Server is only a reference price that we have rent on Amazon Cloud.	According to Specs of Rented Cloud Server	Below cloud server specs could support 1000~2000 monitoings points connected to the system (Server: 8 core 16G Operation System: windows server 2016)		
4G Smart Gateway					
Overview Picture	USAGE&MODULE NAME	DESCRIPTION & SPECIFICATION	QUANTITY	FOB UNIT PRICE (USD)	AMOUNT (USD)
	4G Smart Gateway AWT100-4GHW	Upstream: 4G (MQTT&MODBUS-TCP Protocol) Downstream: RS485 (MODBUS-RTU) Support: up to 20~25 Energy Meters within 400m using RS485 Wired Communication Power Supply: 85~265Vac/Vdc	10 pcs	/	/
	Power Supply Module AWT100-POW	Input: 85~265Vac/Vdc Output: 24Vdc Application: paired with AWT100 Series gateway for 85~265Vac/Vdc power supply input	10 pcs	/	/
3-phase Energy Meter					
Overview Picture	USAGE&MODULE NAME	DESCRIPTION & SPECIFICATION	QUANTITY	FOB UNIT PRICE (USD)	AMOUNT (USD)
	3-phase DIN-rail Energy Meter ADL400	Communication: RS485 (MODBUS-RTU) Harmonic: Total and 2nd-31st harmonic Multi-rates(Optional): 4 Tariff Rates and etc. Rated Voltage: 3x380~456Vac L-L & 3x220~264Vac L-N (45~65Hz) Rated Current: or 3x1(6)A AC (via CTs)	200 pcs	/	/
Paired CTs					
	Split-core Current Trasformer AKH-0.66/K K-φ24	Current Ratio: 150/5A AC Aperture: φ24mm (diameter) Accuracy: Class 1.0 Application: Paired with ADL400/C for current input, suitable for primary current below 150A AC.	600 pcs	/	/

1. Scenario Preset - [3-phase, Centralized, WiFi based Solution]

- (1) There are 10 Areas with 3-phase Power System needed to be monitored
- (2) Each MDB has 20 circuits 3-phase needed to be monitored, circuits' rated voltage is 3x400Vac L-L and 3x230Vac L-N, circuit's rated current is 100A AC.
- (3) For the place that we gonna install energy meter and WiFi gateway, it was covered by stable WiFi signal.
- (4) All 3-phase energy meter will be of partial centralized installation in each MDB, which make it possible for 1 AWT100-WiFiHW WiFi IoT gateway to support 20 (max 25, recommend 20) ADL400/C 3-phase Energy Meters using RS485 wired communication in a close range within 300m.

2. Devices Deployment Plan - [3-phase, Centralized, WiFi based Solution]

Area #1 - Power Circuit [3-phase] #1-1 ~ #1-20:

- 1* AWT100-WiFiHW IoT WiFi Gateway [Support energy meter in Area #1 for WiFi Data Upstream]
- 1* AWT100-POW Power Supply Module [For 85~265Vac/Vdc power supply of AWT100-WiFiHW]
- 20* ADL400/C 3-phase DIN-rail Energy Meter [For monitoring Power Circuit #1-1 ~ #1-20]
- 60* AKH-0.66/K K- 24 150/5 Split-core Current Transformer [Paired with ADL400/C for current input]

Area #10 - Power Circuit [3-phase] #10-1 ~ #10-20:

- 1* AWT100-WiFiHW IoT WiFi Gateway [Support energy meter in Area #10 for WiFi Data Upstream]
- 1* AWT100-POW Power Supply Module [For 85~265Vac/Vdc power supply of AWT100-WiFiHW]
- 20* ADL400/C 3-phase DIN-rail Energy Meter [For monitoring Power Circuit #10-1 ~ #10-20]
- 60* AKH-0.66/K K- 24 150/5 Split-core Current Transformer [Paired with ADL400/C for current input]

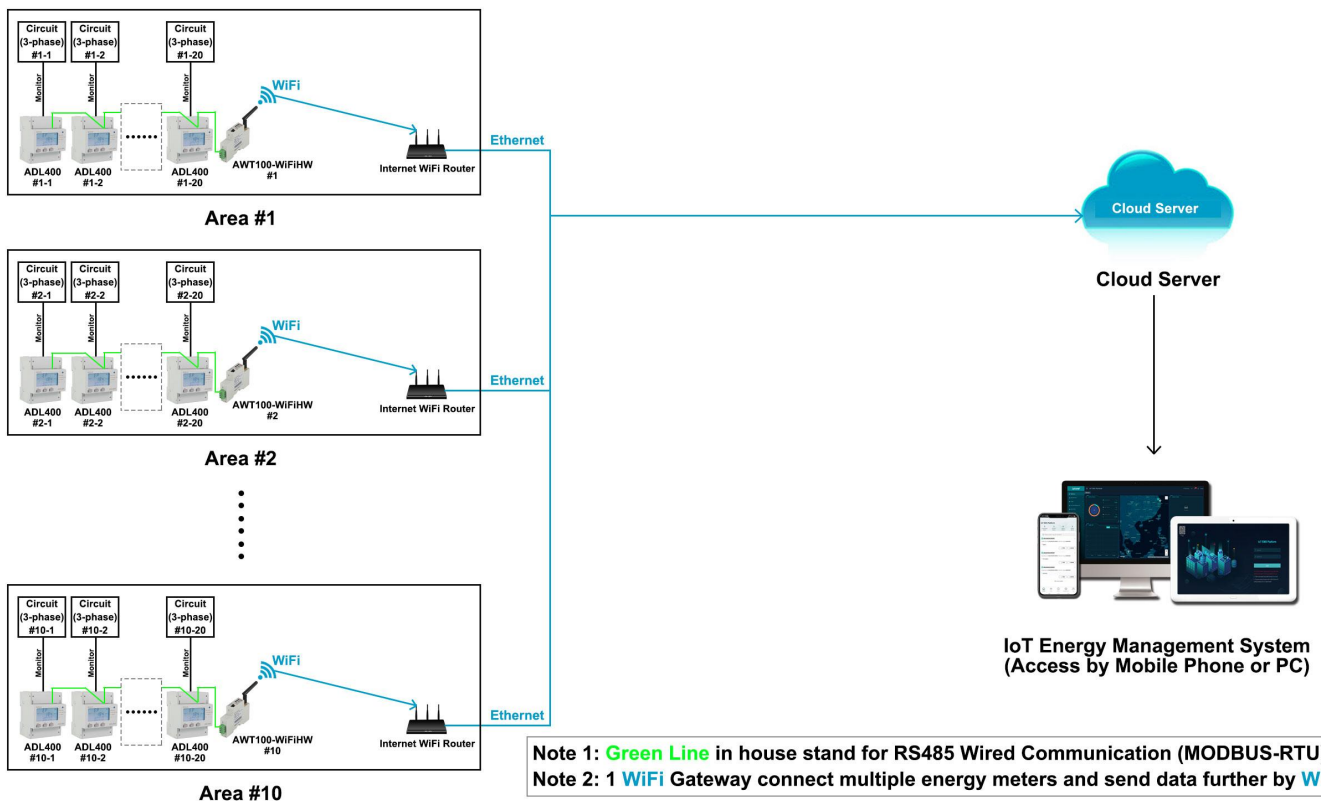

3. Communication Structure&Logic - [3-phase, Centralized, WiFi based Solution]

(1) WiFi Communication could be served as one of the final data upstream methods by sending the data to cloud server deployed in Internet so that Acrel IoT System could be interact with these data collected by bottom metering devices like Energy Meter

(2) AWT100-WiFiHW gateway support upstream of WiFi communication with MQTT and MODBUS-TCP protocol and downstream of RS485 communication based on MODBUS-RTU protocol. ADL400/C support upstream communication of RS485 communication based on MODBUS-RTU protocol.

(3) Based on the communication described in item (2), Acrel AWT100-WiFiHW gateway could receive the data from ADL400/C energy meter using RS485 communication while sending the data further to cloud server using WiFi upstream communication. Thus accomplish a complete communication from bottom metering devices to top system software.

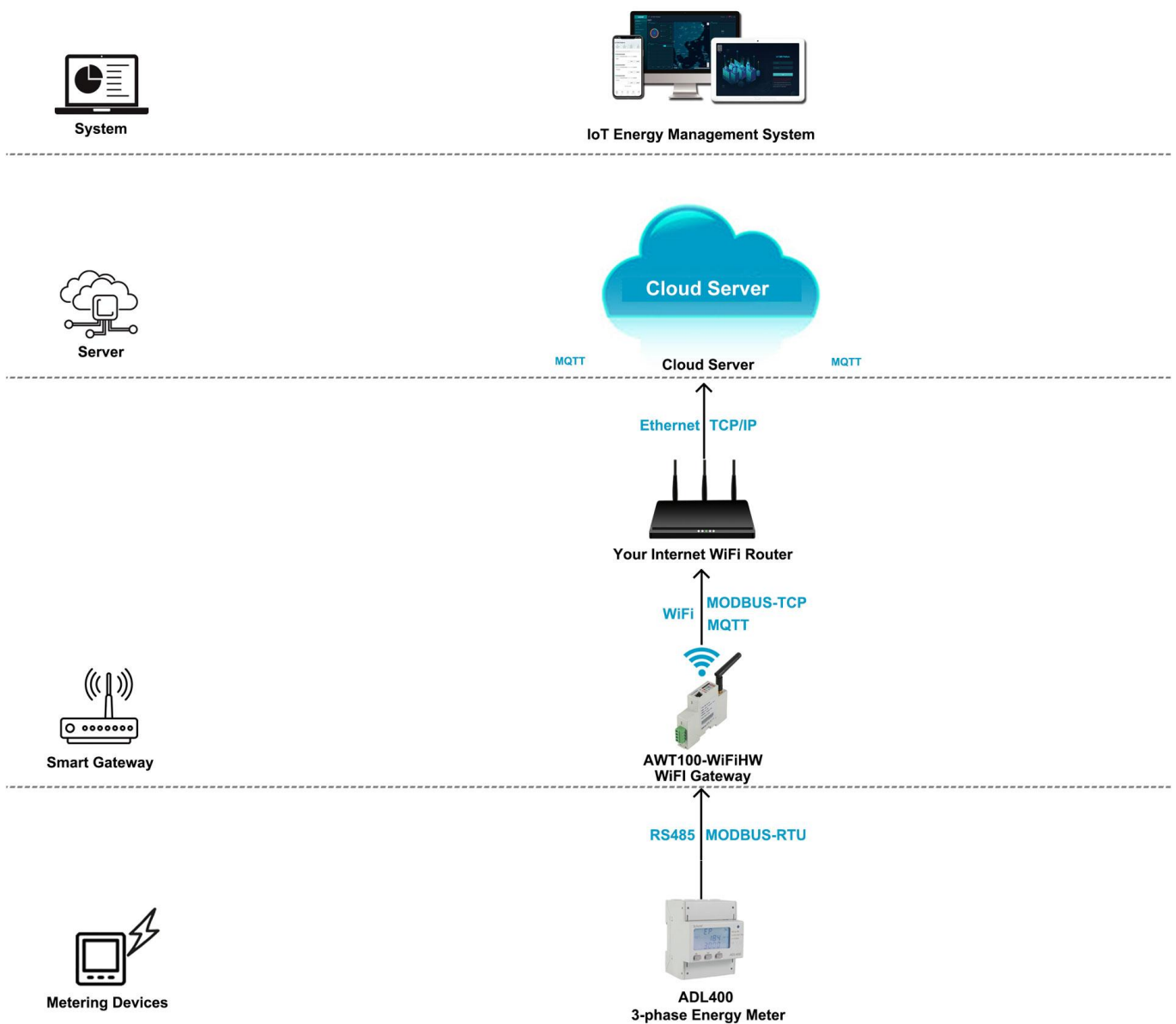

4. Hardware Devices Overview - [3-phase, Centralized, WiFi based Solution]

Model 1: AWT100-WiFiHW IoT WiFi Smart Gateway

- Upstream Comms.: WiFi [MQTT, MODBUS Protocol]-
- Downstream Comms.: RS485 [MODBUS-RTU Protocol]-
- Support: Up to 25 Downstream Devices via RS485.
- Auxiliary Power Supply: 85~265Vac [via AWT100-POW]
- Certificate&Standard: CE; CE-RED; IEC

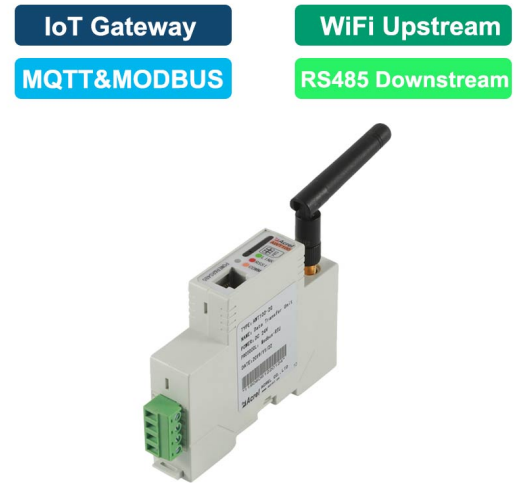

Model 2: AWT100-POW Power Supply Module

- Input: 85~265Vac
- Output: 12Vdc
- Application: Paired with AWT100-4GHW for 85~265Vac Power Supply Input [via PIN L & PIN N]
- Certificate&Standard: CE

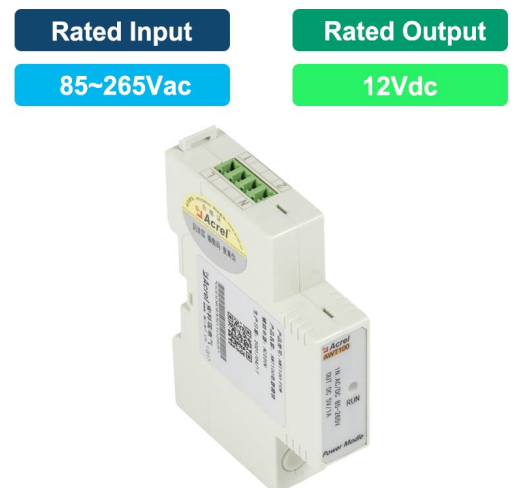

Model 2: ADL400 3-phase AC DIN-rail Energy Meter

- Monitoring: Up 1 circuits 3-phase [AC Metering]
- Rated Voltage: 3x380~456Vac L-L & 3x220~264Vac L-N
- Rated Current: 3x1(6)A AC (via paired CT)
- Wired Comms: RS485 Interface, MODBUS-RTU Protocol
- Certificate&Standard: CE; CE-MID; EAC



3. Hardware Devices Overview - [3-phase, Centralized, WiFi based Solution]

Model 2: AKH-0.66/K K- 24 150/5 Split-core Current Transformer

- Current Ratio: 150A/5A
- Primary Current: 150A
- Secondary Current: 5A
- Accuracy: Class 0.5 or 1.0
- Certificate&Standard: CE

AC

60~400A





Split Core

Class 0.5

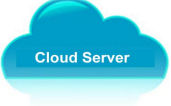

4. Overall Model Selection&Quotation - [3-phase, Centralized, WIFI based Solution]

(1) This Quotation doesn't include freight charge. To gain a complete quotation, please refer the actual quantity that you want to request for the actual order, once we receiving it. We will issue a Official Proforma Invoice with Acrel Stamps on it for later procedure.

System Software					
Name	Description	System Price	Remark (Choose Host Service or Buy-out Service after 3-month Free Trial of Cloud IoT System)		
 Acrel Cloud IoT Energy Management System	1.System support all the meters across the country whose data has been sent to cloud server through 4G,WIFI or Ethernet . 2.Remote meter reading and data collection. 3.Provide IoT APP for mobile phone side and IoT WEB for PC side. 4.Generate energy data report of daily, monthly and annually period with year-on-yeay and period-on-period energy analysis. 5.Provide various alarm function to ensure a stable operation of the system and protect your property. 6.Offer 3-month free trial of system with full technical support as for a test phase or pilot project.	\$0 (recommended in pilot project)	3-month Free Trail (Users don't need to rent a cloud server))		
		\$xxxx/Year (For 200 Points) (Price for Host Service Only, recommended in pilot project)	\$xx to buy Hosting Service for 1 monitoring points connected to the system 1 year (Users don't need to rent a cloud server)		
		\$xxxxPermanent (Limitless Points) (Price for Buy-out Service Only,recommended in late project)	1-time charging of \$xxxx for Buy-out Service of permanent use (Limitless monitoring points and a cloud server need to be rent by users)		
Cloud Server					
Name	Description	Server Renting Price (For Reference Only)	Remark		
 Cloud Server	1.Cloud Server could be rent on the cloud server provider like Amazon Cloud. 2.Users of Cloud IoT Energy Management System only need to rent cloud server when they choose buy-out service of our Cloud IoT System . And if they are using hosting service or 3-month free trial of our Cloud IoT System, we will use our own cloud server which has been rent on Amazon so that users don't need to rent a cloud server. 3.The quotation of Cloud Server is only a reference price that we have rent on Amazon Cloud.	According to Specs of Rented Cloud Server	Below cloud server specs could support 1000~2000 monitoings points connected to the system (Server: 8 core 16G Operation System: windows server 2016)		
WiFi Smart Gateway					
Overview Picture	USAGE&MODULE NAME	DESCRIPTION & SPECIFICATION	QUANTITY	FOB UNIT PRICE (USD)	AMOUNT (USD)
	WiFi Smart Gateway AWT100-WIFIHW	Upstream: WiFi (2.4&5GHz, support MQTT&MODBUS-TCP Protocol) Downstream: RS485 (MODBUS-RTU) Support: up to 20~25 Energy Meters within 400m using RS485 Wired Communication Power Supply: 85~265Vac/Vdc	10 pcs	/	/
	Power Supply Module AWT100-POW	Input: 85~265Vac/Vdc Output: 24Vdc Application: paired with AWT100 Series gateway for 85~265Vac/Vdc power supply input	10 pcs	/	/
3-phase Energy Meter					
Overview Picture	USAGE&MODULE NAME	DESCRIPTION & SPECIFICATION	QUANTITY	FOB UNIT PRICE (USD)	AMOUNT (USD)
	3-phase DIN-rail Energy Meter ADL400	Communication: RS485 (MODBUS-RTU) Harmonic: Total and 2nd-31st harmonic Multi-rates(Optional): 4 Tariff Rates and etc. Rated Voltage: 3x380~456Vac L-L & 3x220~264Vac L-N (45~65Hz) Rated Current: or 3x1(6)A AC (via CTs)	200 pcs	/	/
Paired CTs					
	Split-core Current Transformer AKH-0.66/K K-φ24	Current Ratio: 150/5A AC Aperture: φ24mm (diameter) Accuracy: Class 1.0 Application: Paired with ADL400/C for current input, suitable for primary current below 150A AC.	600 pcs	/	/

0. Scenario Preset - [3-phase, Separate,4G based Solution]

- (1) There are 10 Areas which are far from each other or are hard for RS485 Comms. wiring.
- (2) Each Area has 1 circuit 3-phase that needed to be monitored.
- (3) Each circuit are with rated voltage of 400Vac L-L&230Vac L-N, and with rated current of 150A AC.
- (4) Circuits' current are carried by cable, of which the size was suitable for 24mm aperture. (diameter)
- (5) For the places that we gonna install the wireless energy meter, it's covered by stable 4G signal for 4G communications. All the 4G energy meters will be of separate installation and directly send data to IoT system.

1. Devices Deployment Plan - [3-phase, Separate,4G based Solution]

Area #1 - Power Circuit [3-phase] #1:

- 1* ADW300-4GHW/C 4G 3-phase Energy Meter [For monitoring Power Circuit #1 and 4G Upstream]
- 3* AKH-0.66/K K- 24 150/5 Split-core Current Transformer [For current input of ADW300-4GHW/C]

Area #10 - Power Circuit [3-phase] #10:

- 1* ADW300-4GHW/C 4G 3-phase Energy Meter [For monitoring Power Circuit #10 and 4G Upstream]
- 3* AKH-0.66/K K- 24 150/5 Split-core Current Transformer [For current input of ADW300-4GHW/C]

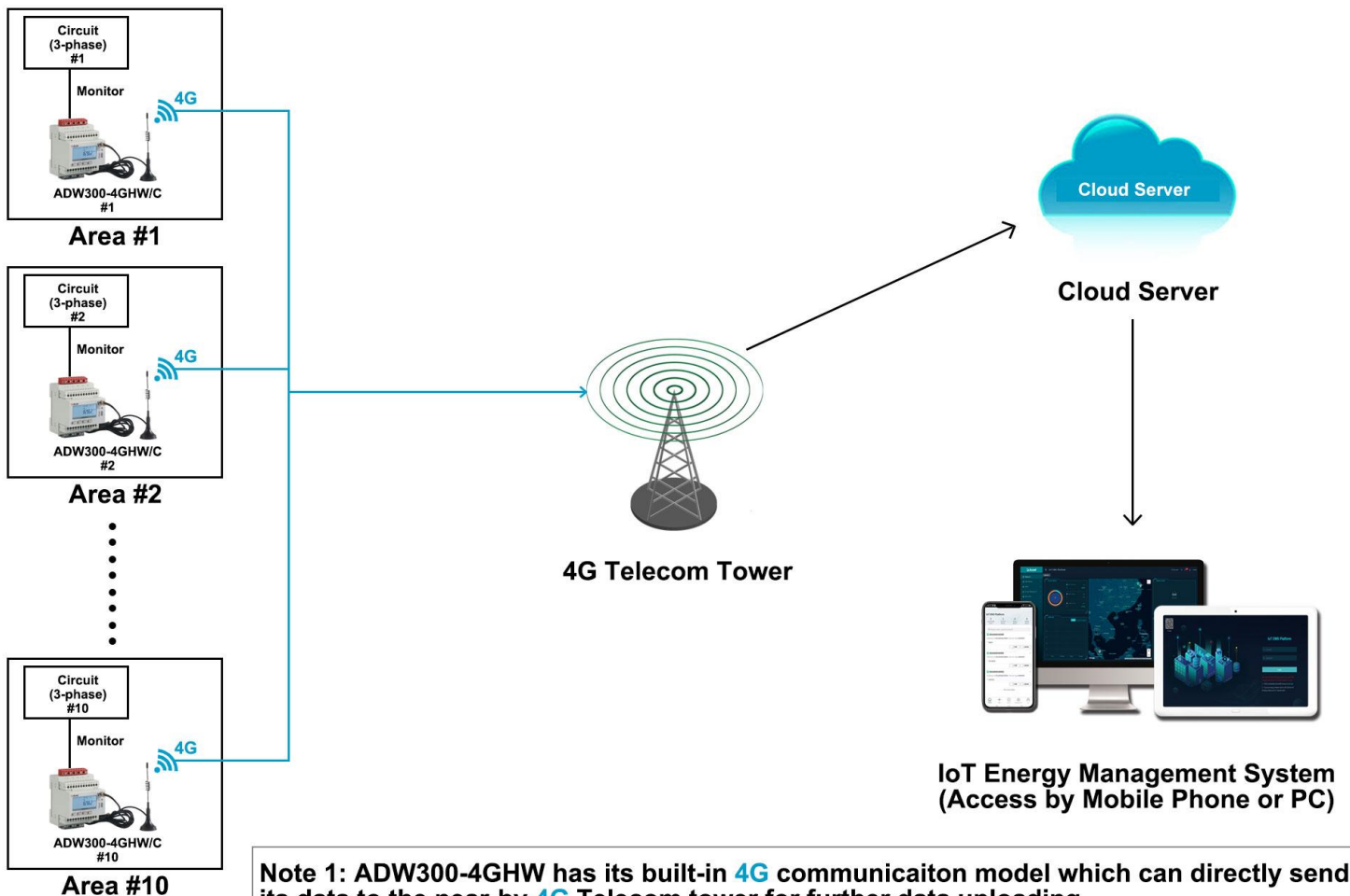

2. Communication Structure&Logic - [3-phase, Separate,4G based Solution]

- (1) 4G Communication could be served as one of the final data upstream methods by sending the data to cloud server deployed in Internet so that Acrel IoT System could be interact with these data collected by bottom metering devices like Energy Meter
- (2) ADW300-4GHW/C Wireless 4G 3-phase Energy Meter has a built-in 4G communication module which allow it to directly send data to local 4G telecom tower through 4G signal based on MQTT and MODBUS-TCP protocol without using a extra 4G IoT Gateway.
- (3) Each ADW300-4GHW/C has a 4G card tray for installing the 4G sim card which could be bought from your local 4G service provider.
- (4) ADW300-4GHW/C also have a RS485 communication normally used for devices adjustment with Acrel ADW300 adjustment software.

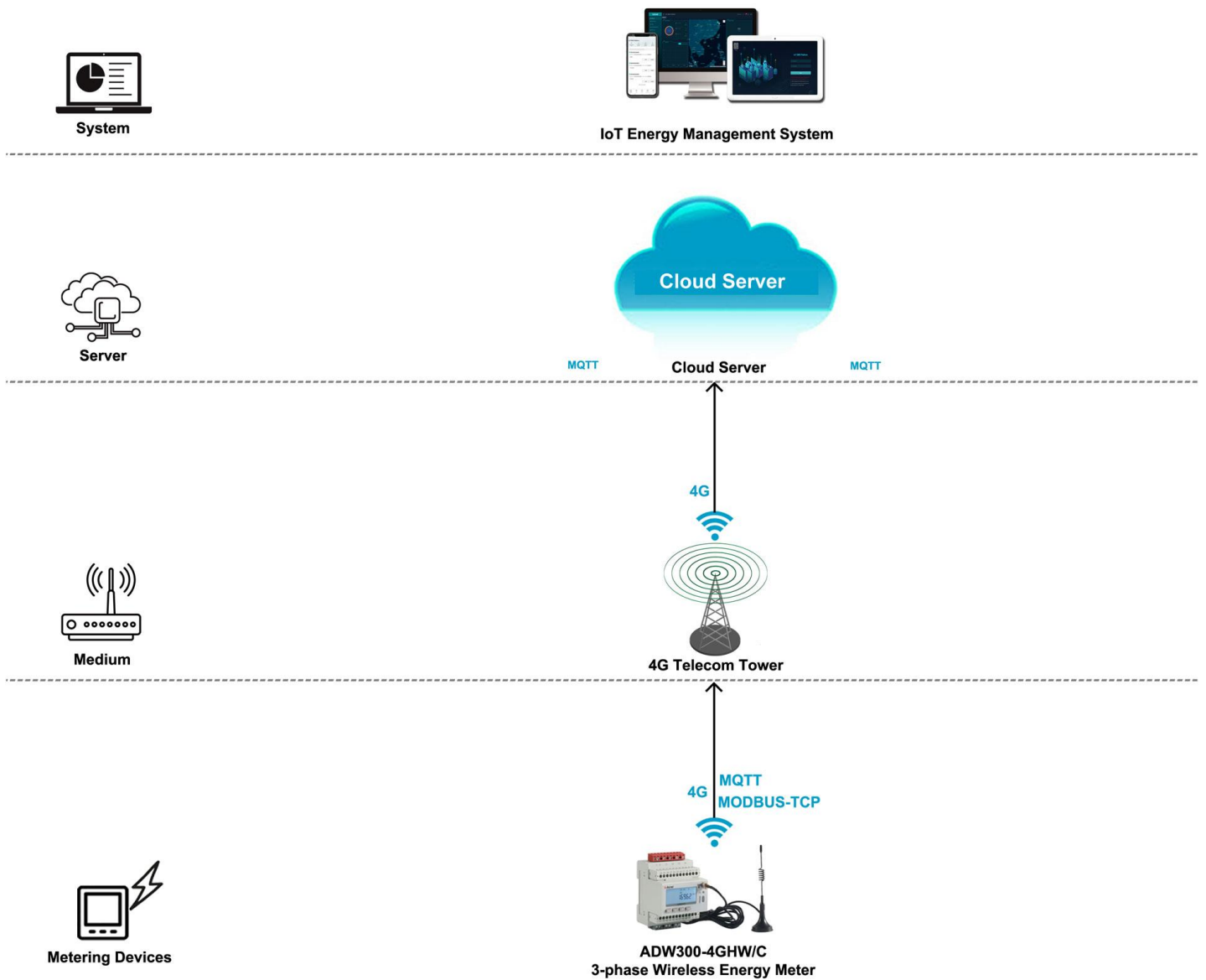

4. Overall Model Selection & Quotation - [3-phase, Separate, 4G based Solution]

(1) This Quotation doesn't include freight charge. To gain a complete quotation, please refer the actual quantity that you want to request for the actual order, once we receiving it. We will issue a Official Proforma Invoice with Acrel Stamps on it for later procedure.

System Software

Name	Description	System Price	Remark (Choose Host Service or Buy-out Service after 3-month Free Trial of Cloud IoT System)
 Acrel Cloud IoT Energy Management System	1. System support all the meters across the country whose data has been sent to cloud server through 4G, WiFi or Ethernet . 2. Remote meter reading and data collection. 3. Provide IoT APP for mobile phone side and IoT WEB for PC side. 4. Generate energy data report of daily, monthly and annually period with year-on-year and period-on-period energy analysis. 5. Provide various alarm function to ensure a stable operation of the system and protect your property. 6. Offer 3-month free trial of system with full technical support as for a test phase or pilot project.	\$0 (recommended in pilot project)	3-month Free Trail (Users don't need to rent a cloud server))
		\$xxx/Year (For 10 Points) (Price for Host Service Only, recommended in pilot project)	\$xx to buy Hosting Service for 1 monitoring points connected to the system 1 year (Users don't need to rent a cloud server)
		\$xxxxPermanent (Limitless Points) (Price for Buy-out Service Only, recommended in late project)	1-time charging of \$xxxx for Buy-out Service of permanent use (Limitless monitoring points and a cloud server need to be rent by users)

Cloud Server

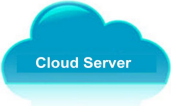
Name	Description	Server Renting Price (For Reference Only)	Remark
 Cloud Server	1. Cloud Server could be rent on the cloud server provider like Amazon Cloud. 2. Users of Cloud IoT Energy Management System only need to rent cloud server when they choose buy-out service of our Cloud IoT System . And if they are using hosting service or 3-month free trial of our Cloud IoT System, we will use our own cloud server which has been rent on Amazon so that users don't need to rent a cloud server. 3. The quotation of Cloud Server is only a reference price that we have rent on Amazon Cloud.	According to Specs of Rented Cloud Server	Below cloud server specs could support 1000~2000 monitoring points connected to the system (Server: 8 core 16G Operation System: windows server 2016)

4G Wireless Energy Meter

Overview Picture	USAGE&MODULE NAME	DESCRIPTION & SPECIFICATION	QUANTITY	FOB UNIT PRICE (USD)	AMOUNT (USD)
	3-phase 4G Wireless Energy Meter ADW300-4GHW/C	Communication: 4G Wireless Communication (with 4G SIM card)&RS485 (MODBUS-RTU) Rated Voltage: 3x380~456Vac L-L or 3x660Vac L-L (45~65Hz) Rated Current: 3x1(6)A AC (via CTs) Auxiliary Power Supply: 85~265Vac	10pcs	/	/

Paired Split-core CT

Overview Picture	USAGE&MODULE NAME	DESCRIPTION & SPECIFICATION	QUANTITY	FOB UNIT PRICE (USD)	AMOUNT (USD)
	Split-core Current Transformer AKH-0.66/K K-φ24	Current Ratio: 150A/5A AC Aperture: φ24mm (diameter) Accuracy: Class 1.0	30pcs	/	/

1. Scenario Preset - [3-phase, Separate, WiFi based Solution]

- (1) There are 10 Area which are far from each other or are hard for RS485 wiring.
- (2) Each Area has only 1 circuit 3-phase that needed to be monitored online.
- (3) Each circuit are with rated voltage of 400Vac L-L&230Vac L-N, and with rated current of 150A AC.
- (4) Circuits' current are carried by cable, of which the size was suitable for 24mm aperture. (diameter)
- (5) For the places that we gonna install the wireless energy meter, it's covered by stable WiFi signal for WiFi communications. All the WiFi energy meters will be of separate installation and directly send data to IoT system.

2. Devices Deployment Plan - [3-phase, Separate, WiFi based Solution]

Area #1 - Power Circuit [3-phase] #1:

- 1* ADW300-WF/C WiFi 3-phase Energy Meter [For monitoring Power Circuit #1 & WiFi Data Upstream]
- 3* AKH-0.66/K K- 24 150/5 Split-core Current Transformer [For current input of ADW300-WF/C]

Area #10 - Power Circuit [3-phase] #10:

- 1* ADW300-WF/C WiFi 3-phase Energy Meter [For monitoring Power Circuit #10 & WiFi Data Upstream]
- 3* AKH-0.66/K K- 24 150/5 Split-core Current Transformer [For current input of ADW300-WF/C]

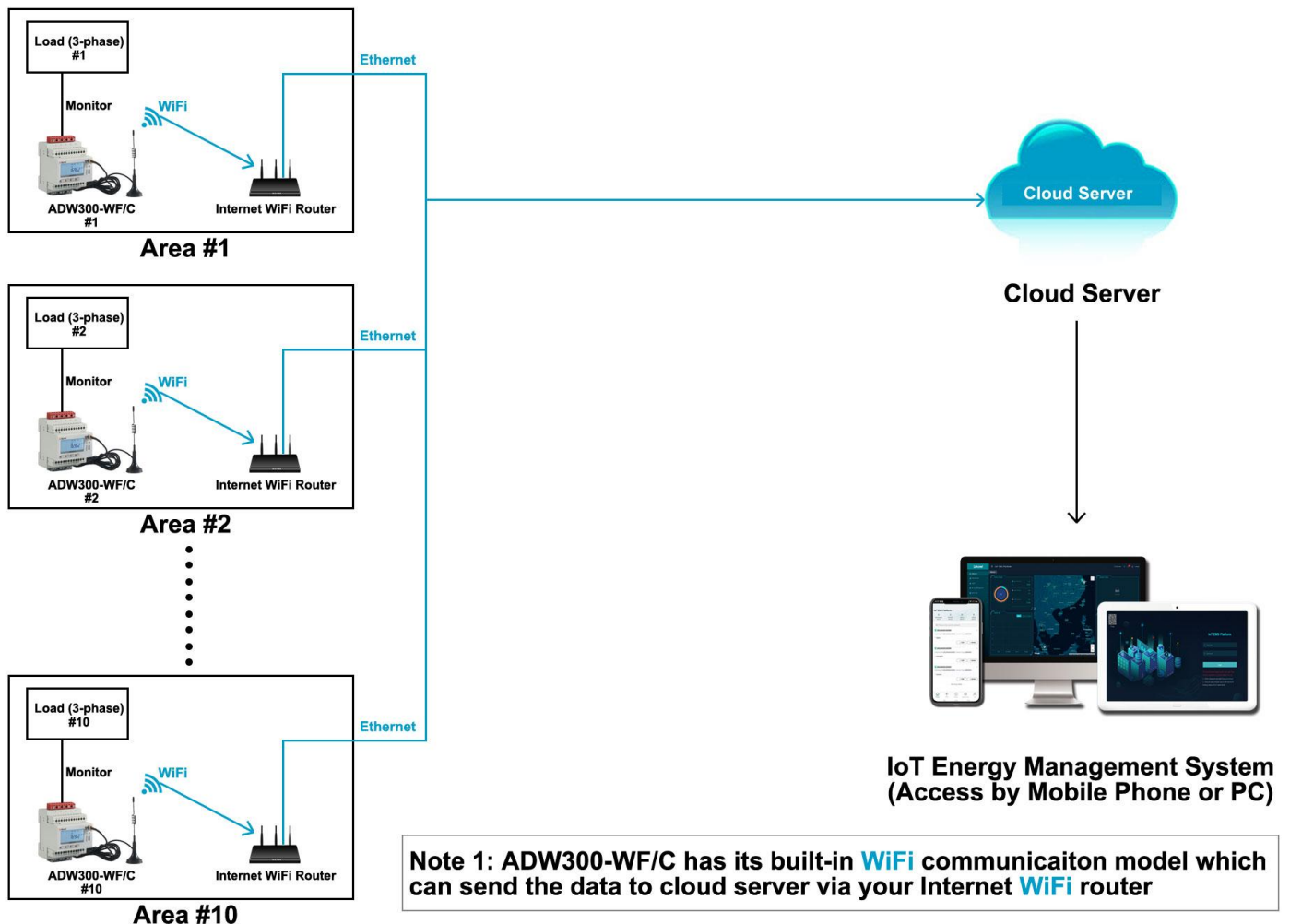

2. Communication Structure&Logic - [3-phase, Separate, WiFi based Solution]

- (1) WiFi Communication could be served as one of the final data upstream methods by sending the data to cloud server deployed in Internet via your WiFi Internet Router so that Acrel IoT System could be interact with these data collected by bottom metering devices like Energy Meter
- (2) ADW300-WF/C Wireless WiFi 3-phase Energy Meter has a built-in WiFi communication module which allow it to directly send data to your Internet WiFi Router using MQTT and MODBUS-TCP protocol without using a extra WiFi IoT Gateway. Then your WiFi router will send the data further to internet for a final data upstreaming.
- (3) In the factory manufacturing stage, we can set the WiFi configuration (WiFi SSID and password) in ADW300-WF/C so that users don't need to set WiFi configuration again.
- (4) ADW300-WF/C also have a RS485 communication normally used for devices adjustment with Acrel ADW300 adjustment software. For example, setting like WiFi configuration could be done.

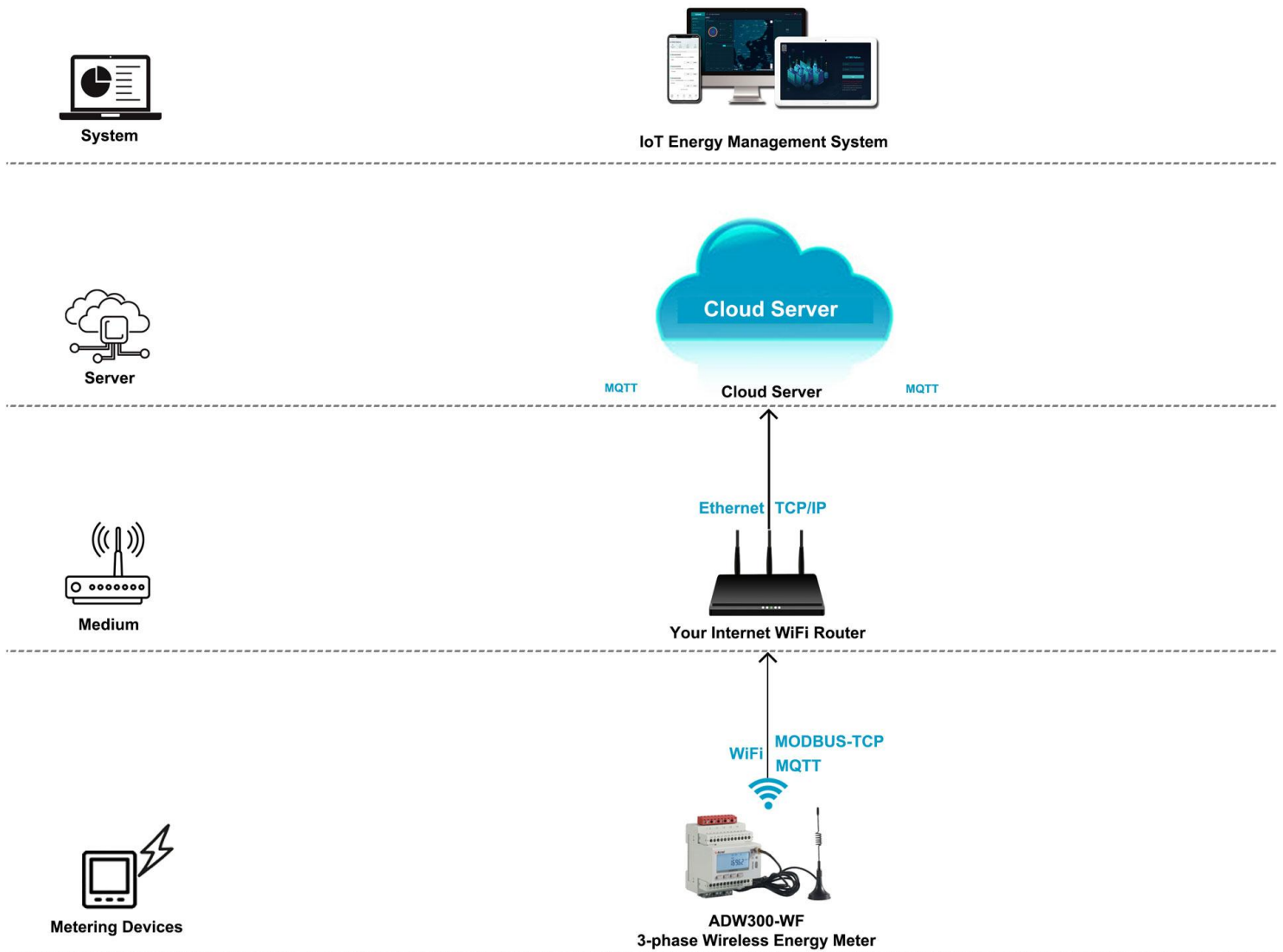

3. Hardware Devices Overview - [3-phase, Separate, WiFi based Solution]

Model 1: ADW300-WF/C WiFi 3-phase IoT Energy Meter

Monitoring: Up to 1 circuits 3-phase [AC Metering]

- Wireless Comms.: WiFi [MQTT, MODBUS Protocol]
- Wired Comms.: RS485 [MODBUS-RTU Protocol]
- Rated Current: 3x1(6)A AC [via -/5A CTs.]
- Rated Voltage: Up to 3x660Vac L-L
- Certificate&Standard: CE, CE-RED





Model 2: AKH-0.66/K K- 24 150/5 Split-core Current Transformer

- Current Ratio: 150A/5A
- Primary Current: 150A
- Secondary Current: 5A
- Accuracy: Class 0.5 or 1.0
- Certificate&Standard: CE

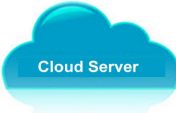

3. Overall Model Selection&Quotation - [3-phase, Separate, WiFi based Solution]

(1) This Quotation doesn't include freight charge. To gain a complete quotation, please refer the actual quantity that you want to request for the actual order, once we receiving it. We will issue a Official Proforma Invoice with Acrel Stamps on it for later procedure.

System Software					
Name	Description	System Price	Remark (Choose Host Service or Buy-out Service after 3-month Free Trial of Cloud IoT System)		
 Acrel Cloud IoT Energy Management System	1.System support all the meters across the country whose data has been sent to cloud server through 4G,WiFi or Ethernet . 2.Remote meter reading and data collection. 3.Provide IoT APP for mobile phone side and IoT WEB for PC side. 4.Generate energy data report of daily, monthly and annually period with year-on-yeay and period-on-period energy analysis. 5.Provide various alarm function to ensure a stable operation of the system and protect your property. 6.Offer 3-month free trial of system with full technical support as for a test phase or pilot project.	\$0 (recommended in pilot project)	3-month Free Trail (Users don't need to rent a cloud server))		
		\$xxx/Year (For 10 Points) (Price for Host Service Only, recommended in pilot project)	\$xx to buy Hosting Service for 1 monitoring points connected to the system 1 year (Users don't need to rent a cloud server)		
		\$xxxxPermanent (Limitless Points) (Price for Buy-out Service Only,recommended in late project)	1-time charging of \$xxxx for Buy-out Service of permanent use (Limitless monitoring points and a cloud server need to be rent by users)		
Cloud Server					
Name	Description	Server Renting Price (For Reference Only)	Remark		
 Cloud Server	1.Cloud Server could be rent on the cloud server provider like Amazon Cloud. 2.Users of Cloud IoT Energy Management System only need to rent cloud server when they choose buy-out service of our Cloud IoT System . And if they are using hosting service or 3-month free trial of our Cloud IoT System , we will use our own cloud server which has been rent on Amazon so that users don't need to rent a cloud server. 3.The quotation of Cloud Server is only a reference price that we have rent on Amazon Cloud.	According to Specs of Rented Cloud Server	Below cloud server specs could support 1000~2000 monitoings points connected to the system (Server: 8 core 16G Operation System: windows server 2016)		
WiFi Wireless Energy Meter					
Overview Picture	USAGE&MODULE NAME	DESCRIPTION & SPECIFICATION	QUANTITY	FOB UNIT PRICE (USD)	AMOUNT (USD)
	3-phase WiFi Wireless Energy Meter ADW300-WF/C	Communication: WiFi Wireless Communication (2.4GHz)&RS485 (MODBUS-RTU) Rated Voltage: 3x380~456Vac L-L or 3x660Vac L-L (45~65Hz) Rated Current: 3x1(6)A AC (via CTs) Auxiliary Power Supply: 85~265Vac	10 pcs	/	/
Paired Split-core CT					
Overview Picture	USAGE&MODULE NAME	DESCRIPTION & SPECIFICATION	QUANTITY	FOB UNIT PRICE (USD)	AMOUNT (USD)
	Split-core Current Transformer AKH-0.66/K K-φ24	Current Ratio: 150/5A AC Aperture: φ24mm (diameter) Accuracy: Class 1.0 Application: For current input of ADW300-WF/C	30 pcs	/	/

0. Scenario Preset - [1-phase, Centralized, 4G based Solution]

- (1) There are 10 Area with 1-phase Power System needed to be monitored.
- (2) Each area has 20 monitoring circuits 1-phase needed to be monitored online.
- (3) Rated voltage of monitoring circuit is 230Vac L-N, rated current of monitoring circuit is 80A AC.
- (4) All 1-phase energy meter will be of partial centralized installation in each area, which make it possible for 1 AWT100-4GHW 4G IoT gateway to support 20 ADL200/C 1-phase Energy Meters using RS485 wired communication in a close range. (1 AWT100-4GHW can support max 25 ADL200/C energy meters if distance allowed (within 400m) and all 25 Energy Meters were of centralized installation along with this 1 AWT100-4GHW)

1. Devices Deployment Plan - [1-phase, Centralized, 4G based Solution]

Area #1 - Power Circuit [1-phase] #1-1 ~ #1-20:

- 1* AWT100-4GHW IoT 4G Gateway [Support 20* Energy Meters in Area #1 for 4G Data Upstream]
- 1* AWT100-POW Power Supply Module [For 85~265Vac/Vdc power supply of AWT100-4GHW]
- 20* ADL200/C 1-phase DIN-rail Energy Meter [For monitoring Power Circuit #1-1 ~ #1-20]

Area #10 - Power Circuit [1-phase] #10-1 ~ #10-20:

- 1* AWT100-4GHW IoT 4G Gateway [Support 20* Energy Meters in Area #10 for 4G Data Upstream]
- 1* AWT100-POW Power Supply Module [For 85~265Vac/Vdc power supply of AWT100-4GHW]
- 20* ADL200/C 1-phase DIN-rail Energy Meter [For monitoring Power Circuit #10-1 ~ #10-20]

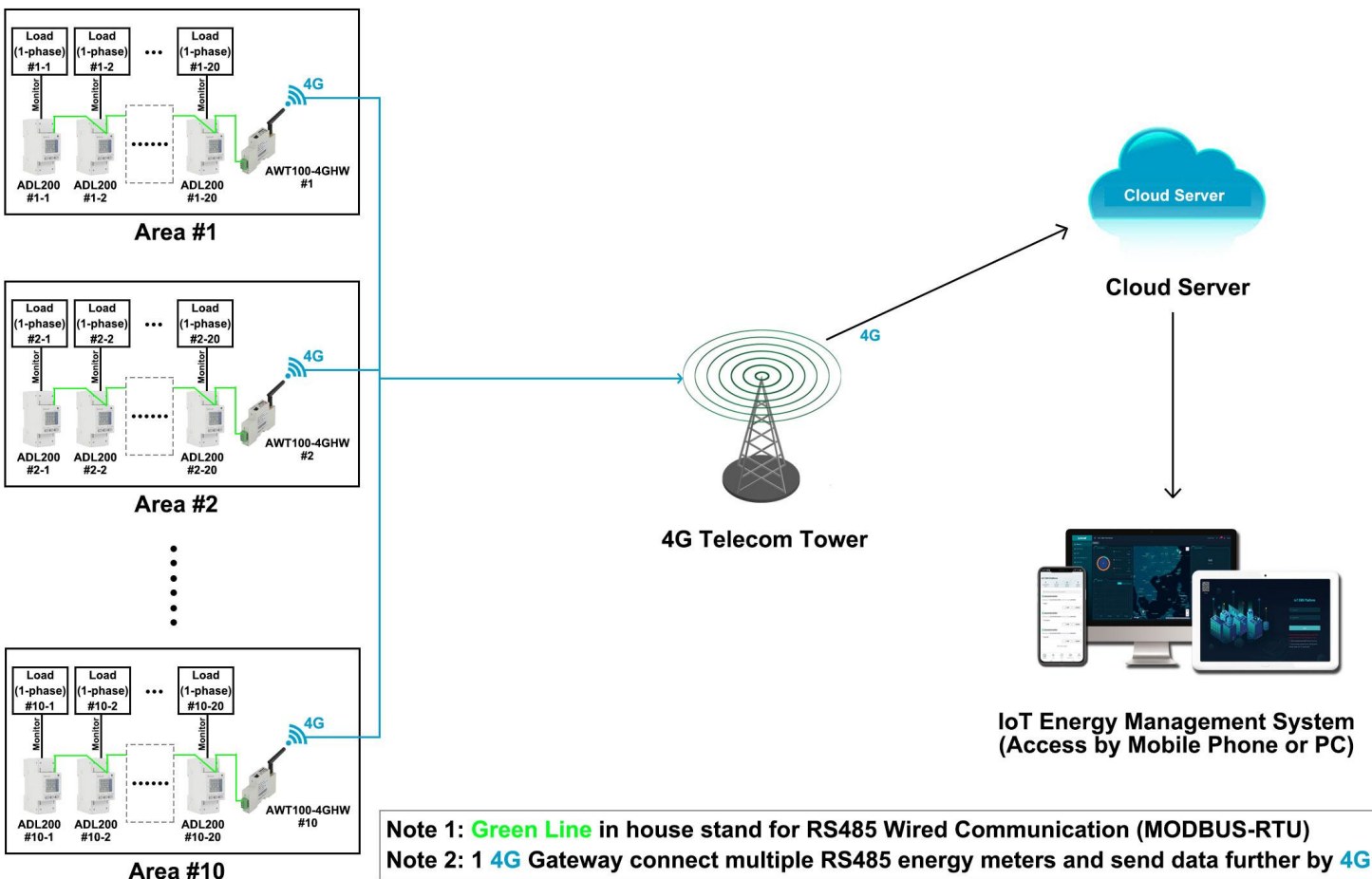

2. Communication Structure&Logic - [1-phase, Centralized, 4G based Solution]

- (1) 4G Communication could be served as one of the final data upstream methods by sending the data to cloud server deployed in Internet so that Acrel IoT System could be interact with these data collected by bottom metering devices like Energy Meter
- (2) AWT100-4GHW gateway support upstream of 4G communication with MQTT and MODBUS-TCP protocol and downstream of RS485 communication based on MODBUS-RTU protocol. ADL200/C support upstream communication of RS485 communication based on MODBUS-RTU protocol.
- (3) Based on the communication described in item (2), Acrel AWT100-4GHW gateway could receive the data from ADL200/C energy meter using RS485 communication while sending the data further to cloud server using 4G upstream communication. Thus accomplish a complete communication from bottom metering devices to top system software.

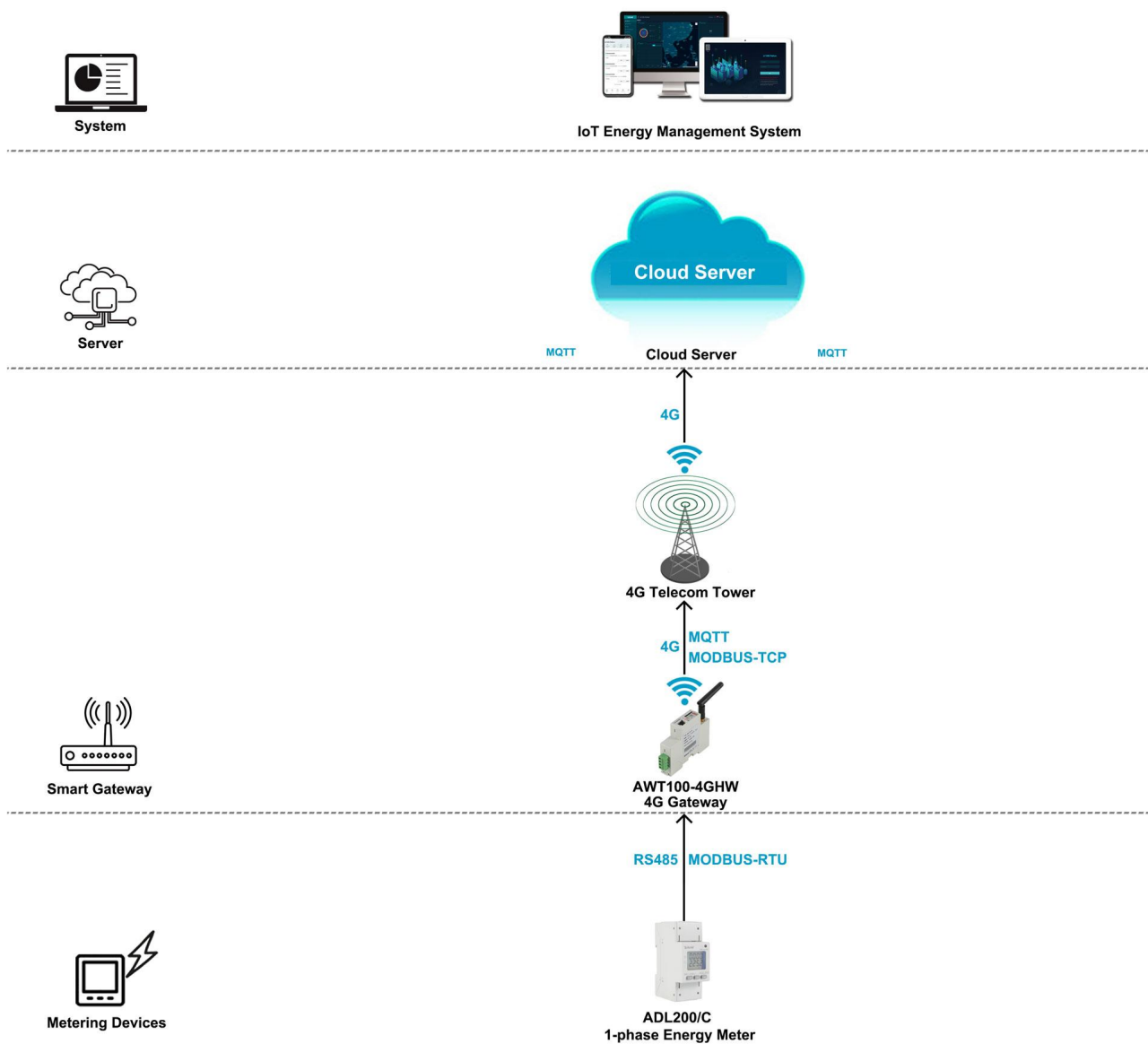

3. Hardware Devices Overview - [1-phase, Centralized, 4G based Solution]

Model 1: AWT1000-4GHW IoT 4G Smart Gateway

- Upstream Comms.: 4G LTE [MQTT, MODBUS Protocol]
- Downstream Comms.: RS485 [MODBUS-RTU Protocol]
- Support: Up to 25 Downstream Devices via RS485.
- Auxiliary Power Supply: 85~265Vac [via AWT100-POW]
- Certificate&Standard: CE; CE-RED; IEC

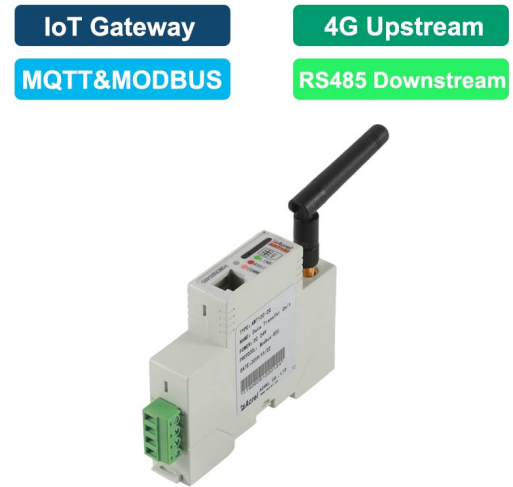

Model 2: AWT100-POW Power Supply Module

- Input: 85~265Vac
- Output: 12Vdc
- Application: Paired with AWT100-4GHW for 85~265Vac Power Supply Input [via PIN L & PIN N]
- Certificate&Standard: CE

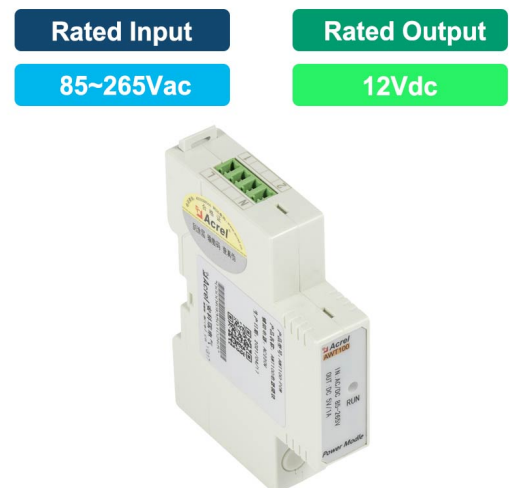





Model 2: ADL200 1-phase AC DIN-rail Energy Meter

- Monitoring: Up 1 circuits 1-phase [AC Metering]
- Rated Voltage: 220~264Vac L-N
- Rated Current: 10(80)A AC (via direct connect)
- Wired Comms: RS485 Interface, MODBUS-RTU Protocol
- Certificate&Standard: CE; CE-MID; EAC

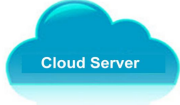

4. Overall Model Selection&Quotation - [1-phase, Centralized, 4G based Solution]

(1) This Quotation doesn't include freight charge. To gain a complete quotation, please refer the actual quantity that you want to request for the actual order, once we receiving it. We will issue a Official Proforma Invoice with Acrel Stamps on it for later procedure.

System Software					
Name	Description	System Price	Remark (Choose Host Service or Buy-out Service after 3-month Free Trial of Cloud IoT System)		
 Acrel Cloud IoT Energy Management System	1.System support all the meters across the country whose data has been sent to cloud server through 4G,WIFI or Ethernet . 2.Remote meter reading and data collection. 3.Provide IoT APP for mobile phone side and IoT WEB for PC side. 4.Generate energy data report of daily, monthly and annually period with year-on-year and period-on-period energy analysis. 5.Provide various alarm function to ensure a stable operation of the system and protect your property. 6.Offer 3-month free trial of system with full technical support as for a test phase or pilot project.	\$0 (recommended in pilot project)	3-month Free Trail (Users don't need to rent a cloud server)		
		\$xxxx/Year (For 200 Points) (Price for Host Service Only, recommended in pilot project)	\$xx to buy Hosting Service for 1 monitoring points connected to the system 1 year (Users don't need to rent a cloud server)		
		\$xxxx/Permanent (Limitless Points) (Price for Buy-out Service Only,recommended in late project)	1-time charging of \$xxxx for Buy-out Service of permanent use (Limitless monitoring points and a cloud server need to be rent by users)		
Cloud Server					
Name	Description	Server Renting Price (For Reference Only)	Remark		
 Cloud Server	1.Cloud Server could be rent on the cloud server provider like Amazon Cloud. 2.Users of Cloud IoT Energy Management System only need to rent cloud server when they choose buy-out service of our Cloud IoT System . And if they are using hosting service or 3-month free trial of our Cloud IoT System , we will use our own cloud server which has been rent on Amazon so that users don't need to rent a cloud server. 3.The quotation of Cloud Server is only a reference price that we have rent on Amazon Cloud.	According to Specs of Rented Cloud Server	Below cloud server specs could support 1000~2000 monitoings points connected to the system (Server: 8 core 16G Operation System: windows server 2016)		
4G Smart Gateway					
Overview Picture	USAGE&MODULE NAME	DESCRIPTION & SPECIFICATION	QUANTITY	FOB UNIT PRICE (USD)	AMOUNT (USD)
	4G Smart Gateway AWT100-4GHW	Upstream: 4G (use 4G SIM card, support MQTT&MODBUS-TCP Protocol) Downstream: RS485 (MODBUS-RTU) Support: up to 20~25 Energy Meters within 400m using RS485 Wired Communication Power Supply: 85~265Vac/Vdc	10 pcs	/	/
	Power Supply Module AWT100-POW	Input: 85~265Vac/Vdc Output: 24Vdc Application: paired with AWT100 Series gateway for 85~265Vac/Vdc power supply input	10 pcs	/	/
1-phase Energy Meter					
Overview Picture	USAGE&MODULE NAME	DESCRIPTION & SPECIFICATION	QUANTITY	FOB UNIT PRICE (USD)	AMOUNT (USD)
	1-phase RS485 Energy Meter ADL200/C	Communication: RS485 (MODBUS-RTU) Multi-rates: 4 Tariff Rates and etc. Rated Voltage: 220~264Vac L-N (45~65Hz) Rated Current: 10(80)A AC (via direct connect)	200 pcs		

1. Scenario Preset - [1-phase, Centralized, WiFi based Solution]

- (1) There are 10 Area with 1-phase Power System needed to be monitored.
- (2) Each area has 20 monitoring circuits 1-phase needed to be monitored online.
- (2) Rated voltage of monitoring circuit is 230Vac L-N, rated current of monitoring circuit is 80A AC.
- (3) All 1-phase energy meter will be of partial centralized installation in each area, which make it possible for 1 AWT100-WiFiHW WiFi IoT gateway to support 20 ADL200/C 1-phase Energy Meters using RS485 wired communication in a close range. (1 AWT100-WiFiHW can support max 25 ADL200/C energy meters if distance allowed (within 400m) and all 25 Energy Meters were of centralized installation along with this 1 AWT100-WiFiHW)

2. Devices Deployment Plan - [1-phase, Centralized, WiFi based Solution]

Area #1 - Power Circuit [1-phase] #1-1 ~ #1-20:

- 1* AWT100-WiFiHW WiFi Gateway [Support 20* Energy Meters in Area #1 for WiFi Data Upstream]
- 1* AWT100-POW Power Supply Module [For 85~265Vac/Vdc power supply of AWT100-WiFiHW]
- 20* ADL200/C 1-phase DIN-rail Energy Meter [For monitoring Power Circuit #1-1 ~ #1-20]

Area #10 - Power Circuit [1-phase] #10-1 ~ #10-20:

- 1* AWT100-WiFiHW WiFi Gateway [Support 20* Energy Meters in Area #10 for WiFi Data Upstream]
- 1* AWT100-POW Power Supply Module [For 85~265Vac/Vdc power supply of AWT100-WiFiHW]
- 20* ADL200/C 1-phase DIN-rail Energy Meter [For monitoring Power Circuit #10-1 ~ #10-20]

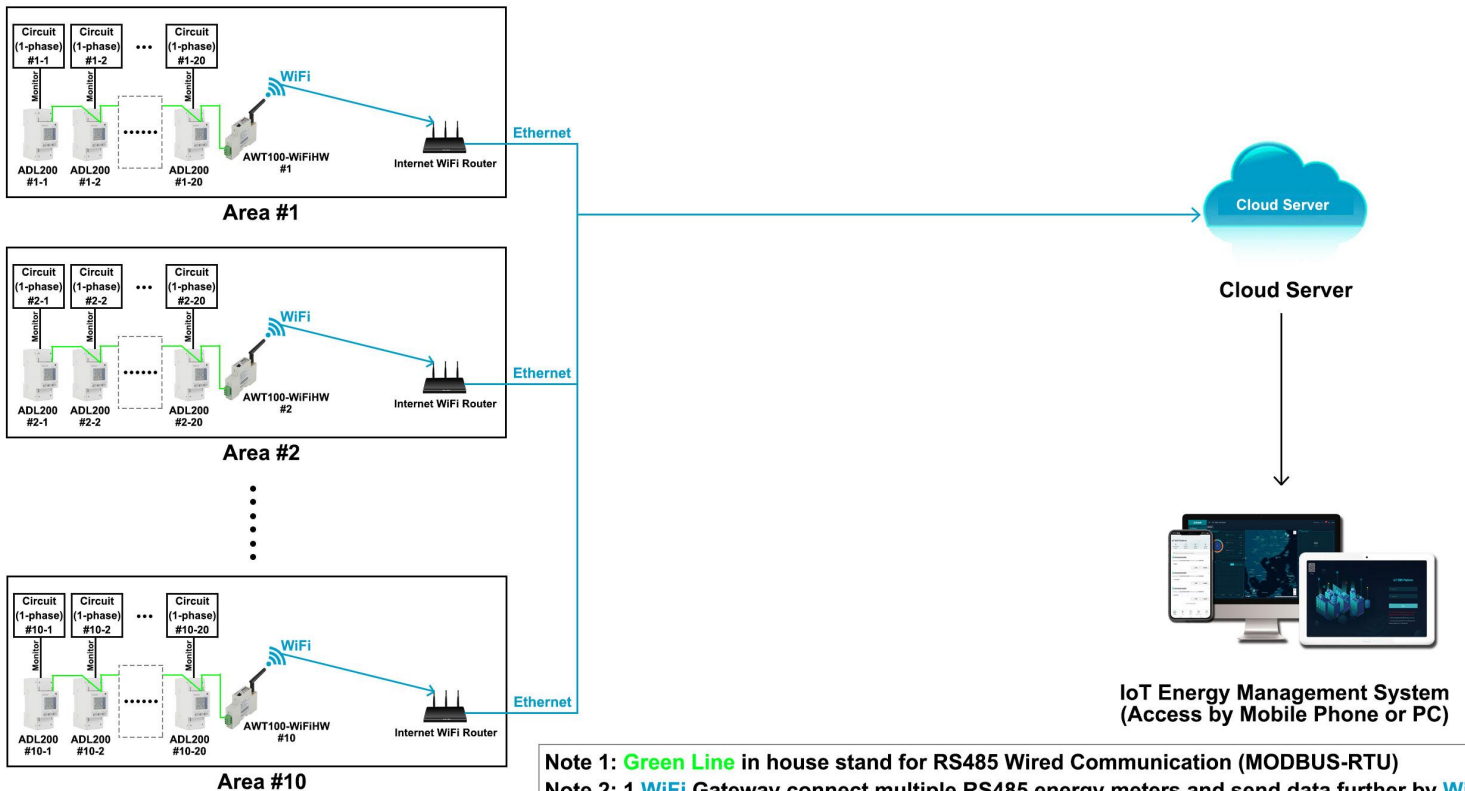

3. Communication Structure&Logic - [1-phase, Centralized, WiFi based Solution]

- (1) WiFi Communication could be served as one of the final data upstream methods by sending the data to cloud server deployed in Internet so that Acrel IoT System could be interact with these data collected by bottom metering devices like Energy Meter
- (2) AWT100-WiFiHW gateway support upstream of WiFi communication with MQTT and MODBUS-protocol and downstream of RS485 communication based on MODBUS-RTU protocol. ADL200/C support upstream communication of RS485 communication based on MODBUS-RTU protocol.
- (3) Based on the communication described in item (2), Acrel AWT100-WiFiHW gateway could receive the data from ADL200/C energy meter using RS485 communication while sending the data further to cloud server using WiFi upstream communication. Thus accomplish a complete communication from bottom metering devices to top system software.

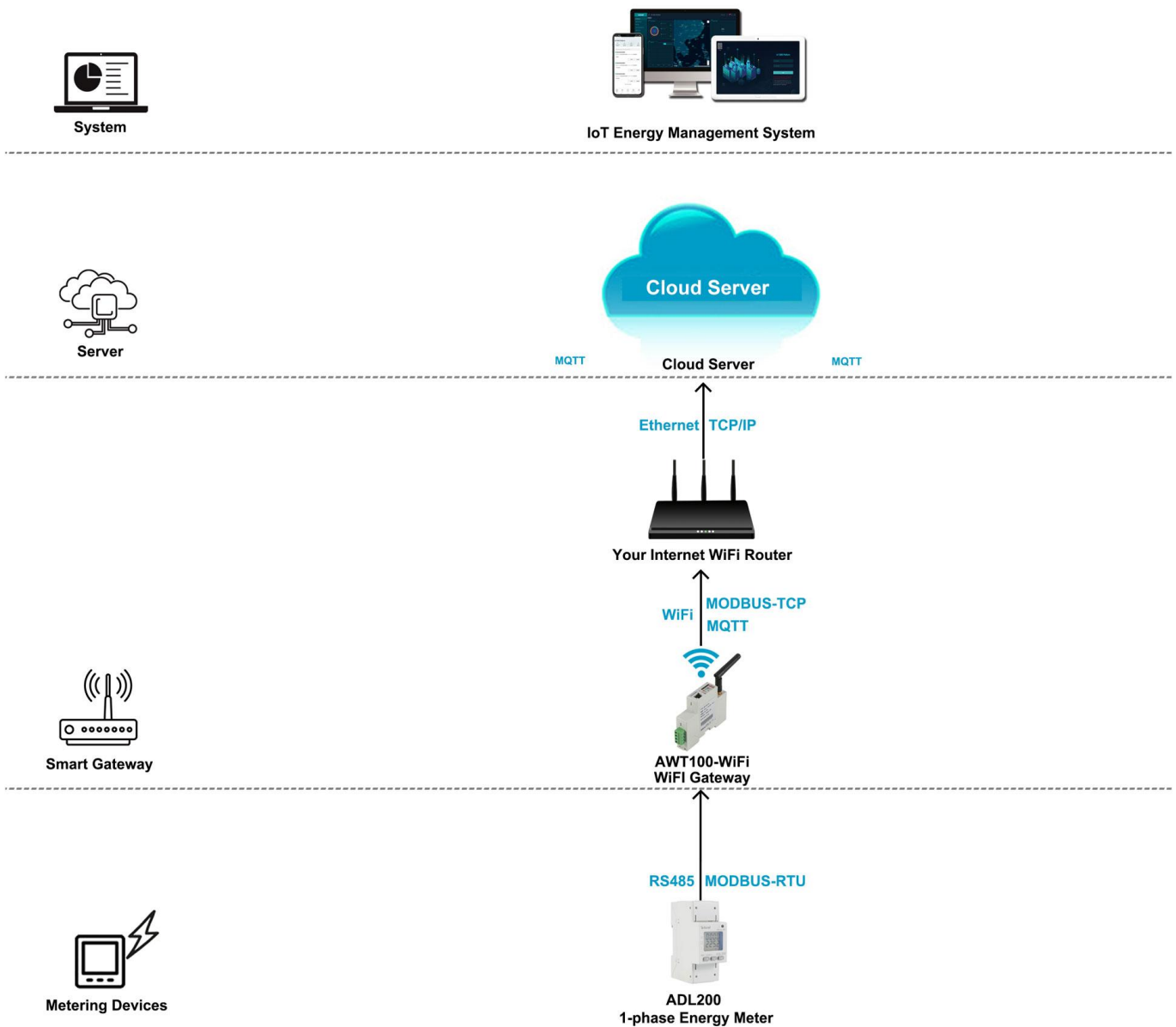

4. Hardware Devices Overview - [1-phase, Centralized, WiFi based Solution]

Model 1: AWT1000-WiFiHW IoT WiFi Smart Gateway

- Upstream Comms.: WiFi [MQTT, MODBUS Protocol]
- Downstream Comms.: RS485 [MODBUS-RTU Protocol]
- Support: Up to 25 Downstream Devices via RS485.
- Auxiliary Power Supply: 85~265Vac [via AWT100-POW]
- Certificate&Standard: CE; CE-RED; IEC

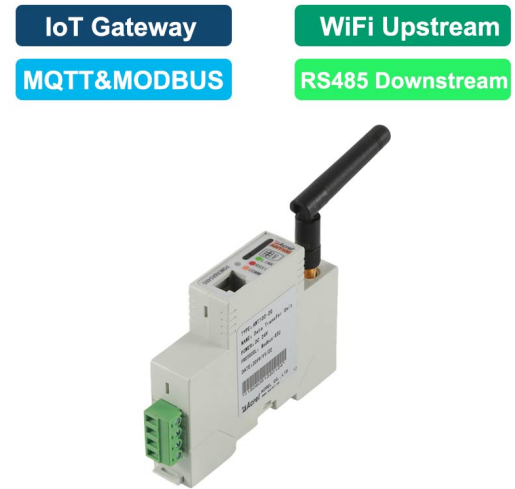

Model 2: AWT100-POW Power Supply Module

- Input: 85~265Vac
- Output: 12Vdc
- Application: Paired with AWT100-4GHW for 85~265Vac Power Supply Input [via PIN L & PIN N]
- Certificate&Standard: CE

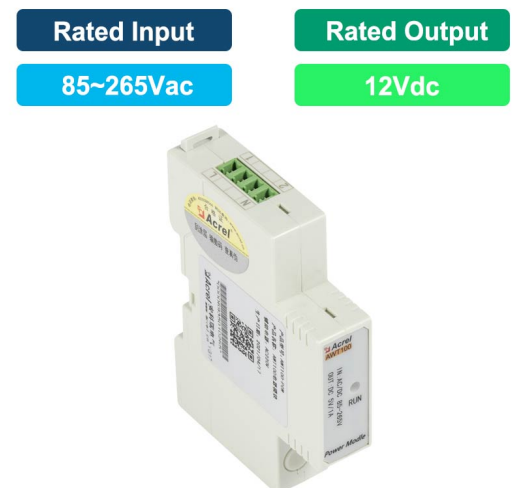





Model 2: ADL200 1-phase AC DIN-rail Energy Meter

- Monitoring: Up 1 circuits 1-phase [AC Metering]
- Rated Voltage: 220~264Vac L-N
- Rated Current: 10(80)A AC (via direct connect)
- Wired Comms: RS485 Interface, MODBUS-RTU Protocol
- Certificate&Standard: CE; CE-MID; EAC

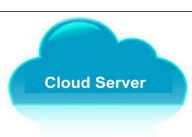

5. Overall Model Selection&Quotation - [1-phase, Centralized, WiFi based Solution]

(1) This Quotation doesn't include freight charge. To gain a complete quotation, please refer the actual quantity that you want to request for the actual order, once we receiving it. We will issue a Official Proforma Invoice with Acrel Stamps on it for later procedure.

System Software					
Name	Description	System Price	Remark (Choose Host Service or Buy-out Service after 3-month Free Trial of Cloud IoT System)		
 Acrel Cloud IoT Energy Management System	1.System support all the meters across the country whose data has been sent to cloud server through 4G,WiFi or Ethernet . 2.Remote meter reading and data collection. 3.Provide IoT APP for mobile phone side and IoT WEB for PC side. 4.Generate energy data report of daily, monthly and annually period with year-on-yeay and period-on-period energy analysis. 5.Provide various alarm function to ensure a stable operation of the system and protect your property. 6.Offer 3-month free trial of system with full technical support as for a test phase or pilot project.	\$0 (recommended in pilot project)	3-month Free Trail (Users don't need to rent a cloud server))		
		\$xxx/Year (For 200 Points) (Price for Host Service Only, recommended in pilot project)	\$xx to buy Hosting Service for 1 monitoring points connected to the system 1 year (Users don't need to rent a cloud server)		
		\$xxxPermanent (Limitless Points) (Price for Buy-out Service Only,recommended in late project)	1-time charging of \$xxx for Buy-out Service of permanent use (Limitless monitoring points and a cloud server need to be rent by users)		
Cloud Server					
Name	Description	Server Renting Price (For Reference Only)	Remark		
 Cloud Server	1.Cloud Server could be rent on the cloud server provider like Amazon Cloud. 2.Users of Cloud IoT Energy Management System only need to rent cloud server when they choose buy-out service of our Cloud IoT System . And if they are using hosting service or 3-month free trial of our Cloud IoT System , we will use our own cloud server which has been rent on Amazon so that users don't need to rent a cloud server. 3.The quotation of Cloud Server is only a reference price that we have rent on Amazon Cloud.	According to Specs of Rented Cloud Server	Below cloud server specs could support 1000-2000 monitoings points connected to the system (Server: 8 core 16G Operation System: windows server 2016)		
WiFi Smart Gateway					
Overview Picture	USAGE&MODULE NAME	DESCRIPTION & SPECIFICATION	QUANTITY	FOB UNIT PRICE (USD)	AMOUNT (USD)
	WiFi Smart Gateway AWT100-WiFiHW	Upstream: WiFi (2.4GHz, support MQTT&MODBUS-TCP Protocol) Downstream: RS485 (MODBUS-RTU) Support: up to 20~25 Energy Meters within 400m using RS485 Wired Communication Power Supply: 85~265Vac/Vdc	10 pcs	/	/
	Power Supply Module AWT100-POW	Input: 85~265Vac/Vdc Output: 24Vdc Application: paired with AWT100 Series gateway for 85~265Vac/Vdc power supply input	10 pcs	/	/
1-phase Energy Meter					
Overview Picture	USAGE&MODULE NAME	DESCRIPTION & SPECIFICATION	QUANTITY	FOB UNIT PRICE (USD)	AMOUNT (USD)
	1-phase RS485 Energy Meter ADL200/C	Communication: RS485 (MODBUS-RTU) Multi-rates: 4 Tariff Rates and etc. Rated Voltage: 220~264Vac L-N (45~65Hz) Rated Current: 10(80)A AC (via direct connect)	200 pcs		

1. Scenario Preset - [1-phase, Separate,4G based Solution]

- (1) There are 10 Areas power by 1-phase power system, each area is far from each other so impossible for centralized installation of energy meters.
- (2) For each area, we need to monitor 1 circuit 1-phase of it for monitoring the overall area's load power consumption.
- (3) Rated voltage of this main incoming circuit 1-phase is 230Vac L-N, and rated/max current was no more than 100A AC.
- (4) For the places that we gonna install the energy meter, they are covered by stable 4G signal.
- (5) Eventually, for each area we only need 1 pcs ADW310-D16-4GHW/C 1-phase 4G Energy Meter

2. Devices Deployment Plan - [1-phase, Separate,4G based Solution]

Area - Power Circuit (1-phase) #1:

- 1* ADW310-D16-4GHW/C 4G 1-phase Energy Meter [For monitoring Power Circuit #1 & 4G Upstream]

.

Area - Power Circuit (1-phase) #10:

- 1* ADW310-D16-4GHW/C 4G 1-phase Energy Meter [For monitoring Power Circuit #10 & 4G Upstream]

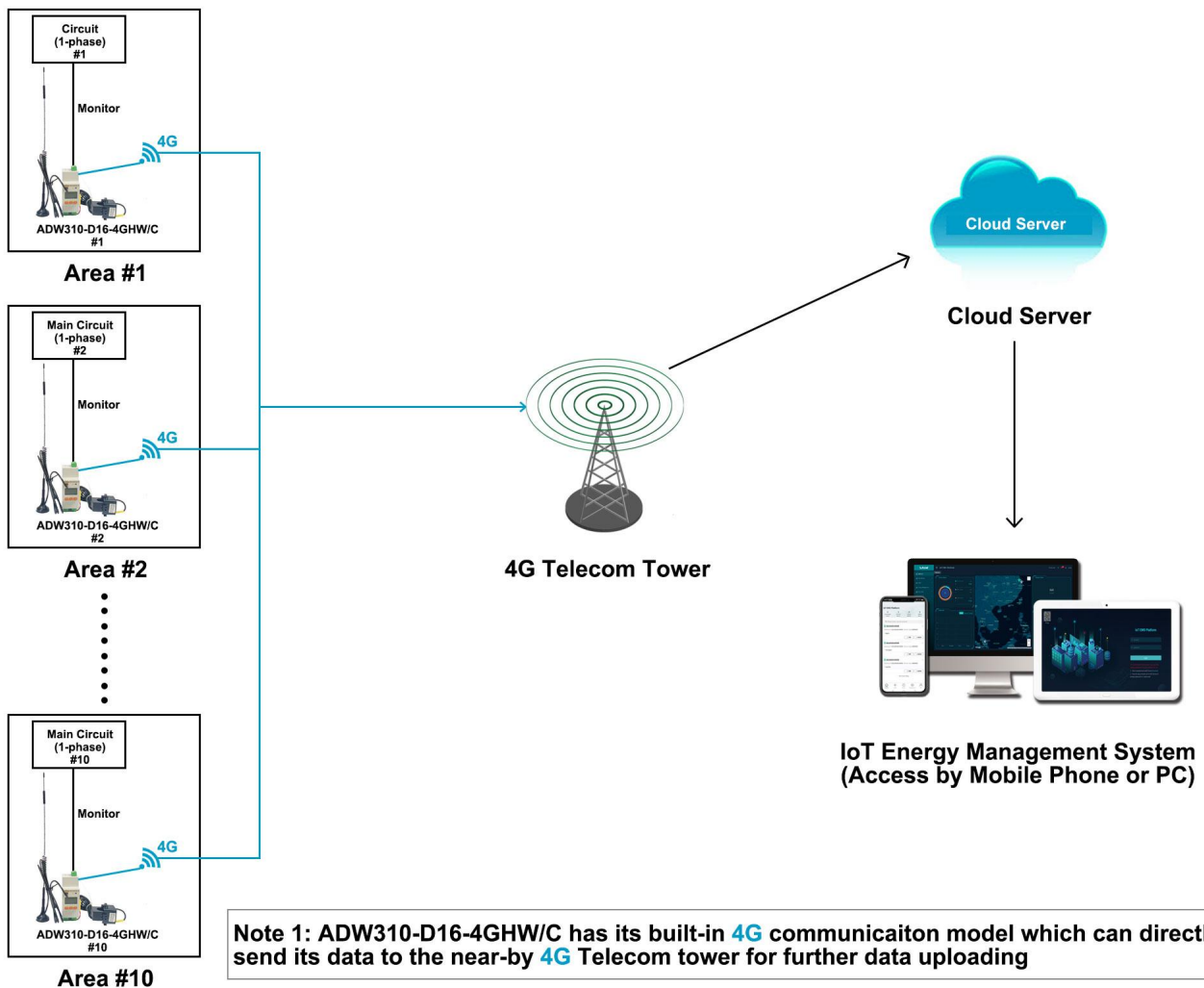

3. Communication Structure&Logic - [1-phase, Separate,4G based Solution]

- (1) 4G Communication could be served as one of the final data upstream methods by sending the data to cloud server deployed in Internet so that Acrel IoT System could be interact with these data collected by bottom metering devices like Energy Meter
- (2) ADW310-D16-4GHW/C Wireless 4G 1-phase Energy Meter has a built-in 4G communication module which allow it to directly send data to local 4G telecom tower through 4G signal based on MQTT and MODBUS-TCP protocol without using a extra 4G IoT Gateway.
- (3) Each ADW310-D16-4GHW/C has a 4G card tray for installing the 4G sim card which could be bought from your local 4G service provider.
- (4) ADW310-D16-4GHW/C also have a RS485 communication normally used for devices adjustment with Acrel ADW310 adjustment software.

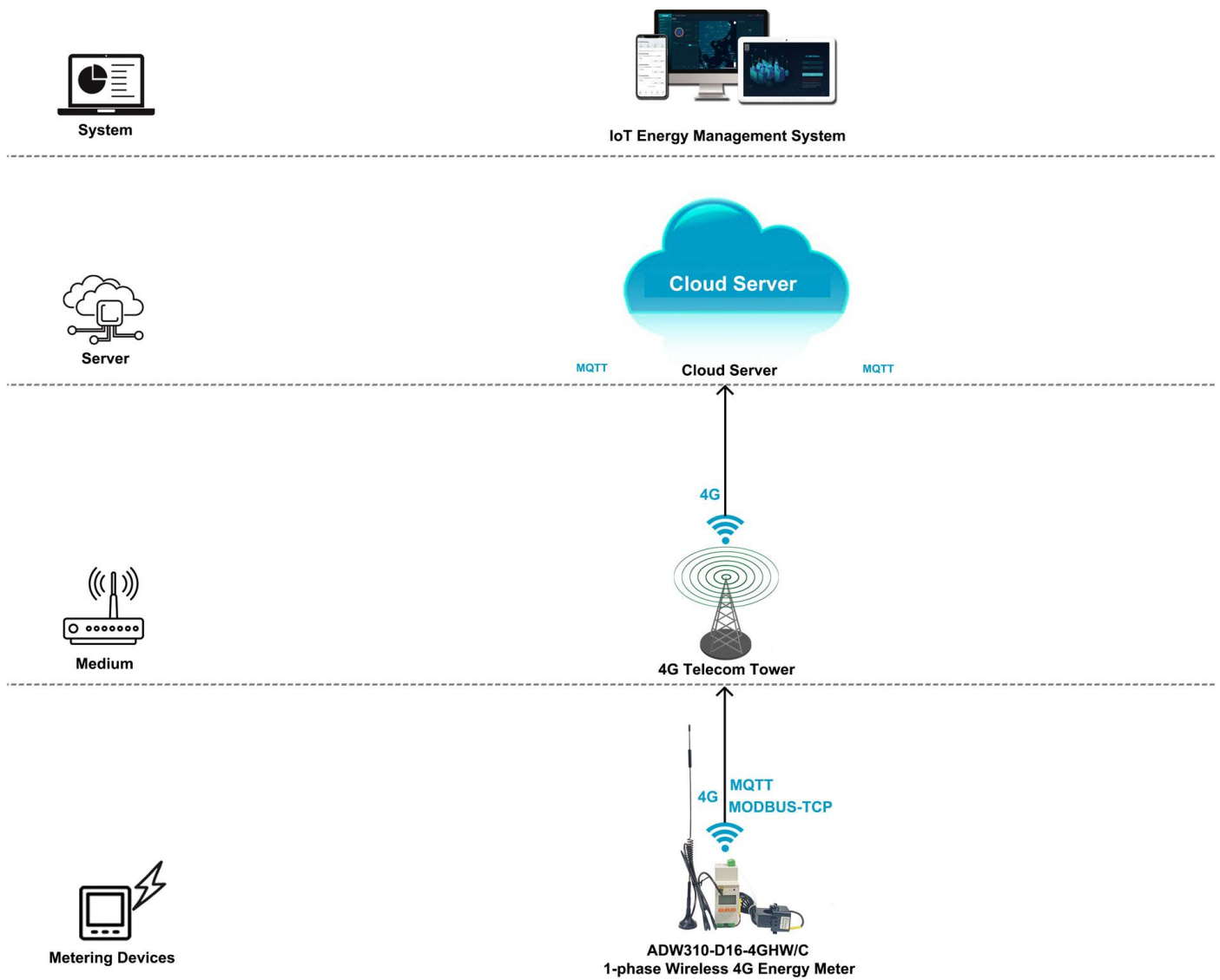



4. Hardware Devices Overview - [1-phase, Separate,4G based Solution]**Model 1: ADW310-Dxx-4GHW/C 4G 1-phase IoT Energy Meter**

- Monitoring: Up to 1 circuits 3-phase [AC Metering]
- Wireless Comms.: 4G LTE [MQTT, MODBUS Protocol]
- Wired Comms.: RS485 [MODBUS-RTU Protocol]
- Rated Current: 3x1(6)A AC [via -/5A CTs.]
- Rated Voltage: Up to 220~264Vac L-N
- Certificate&Standard: CE

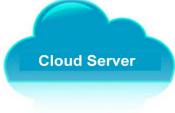

5. Overall Model Selection&Quotation - [1-phase, Separate,4G based Solution]

(1) This Quotation doesn't include freight charge. To gain a complete quotation, please refer the actual quantity that you want to request for the actual order, once we receiving it. We will issue a Official Proforma Invoice with Acrel Stamps on it for later procedure.

System Software					
Name	Description	System Price	Remark (Choose Host Service or Buy-out Service after 3-month Free Trial of Cloud IoT System)		
 Acrel Cloud IoT Energy Management System	1.System support all the meters across the country whose data has been sent to cloud server through 4G,WiFi or Ethernet . 2.Remote meter reading and data collection. 3.Provide IoT APP for mobile phone side and IoT WEB for PC side. 4.Generate energy data report of daily, monthly and annually period with year-on-yeay and period-on-period energy analysis. 5.Provide various alarm function to ensure a stable operation of the system and protect your property. 6.Offer 3-month free trial of system with full technical support as for a test phase or pilot project.	\$0 (recommended in pilot project)	3-month Free Trail (Users don't need to rent a cloud server))		
		\$xxx/Year (For 10 Points) (Price for Host Service Only, recommended in pilot project)	\$xx to buy Hosting Service for 1 monitoring points connected to the system 1 year (Users don't need to rent a cloud server)		
		\$xxxx/Permanent (Limitless Points) (Price for Buy-out Service Only,recommended in late project)	1-time charging of \$xxxx for Buy-out Service of permanent use (Limitless monitoring points and a cloud server need to be rent by users)		
Cloud Server					
Name	Description	Server Renting Price (For Reference Only)	Remark		
 Cloud Server	1.Cloud Server could be rent on the cloud server provider like Amazon Cloud. 2.Users of Cloud IoT Energy Management System only need to rent cloud server when they choose buy-out service of our Cloud IoT System . And if they are using hosting service or 3-month free trial of our Cloud IoT System, we will use our own cloud server which has been rent on Amazon so that users don't need to rent a cloud server. 3.The quotation of Cloud Server is only a reference price that we have rent on Amazon Cloud.	According to Specs of Rented Cloud Server	Below cloud server specs could support 1000~2000 monitoings points connected to the system (Server: 8 core 16G Operation System: windows server 2016)		
4G Wireless Energy Meter					
Overview Picture	USAGE&MODULE NAME	DESCRIPTION & SPECIFICATION	QUANTITY	FOB UNIT PRICE (USD)	AMOUNT (USD)
	1-phase 4G Wireless Energy Meter ADW310-D16-4GHW/C	Communication: 4G (MODBUS-TCP, MQTT) & RS485 (MODBUS-RTU) Rated Voltage: 220~264Vac L-N Rated Current: 20(100)A AC (via paired external CTs)	10 pcs	\$ (Including both Energy meter and External CTs)	
	Paired 1* External Split-core Current Trasnformer	Current Ratio: 100A/25mA AC Aperture: φ16mm Application: Paired with ADW310-D16-WF/C for current input	10 pcs		

1. Scenario Preset - [1-phase, Separate, WiFi based Solution]

- (1) There are 10 Areas power by 1-phase power system, each area is far from each other so impossible for centralized installation of energy meters.
- (2) For each area, we need to monitor 1 circuit 1-phase of it for monitoring the overall area's load power consumption.
- (3) Rated voltage of this main incoming circuit 1-phase is 230Vac L-N, and rated/max current was no more than 100A AC.
- (4) For the places that we gonna install the energy meter, they are covered by stable WiFi signal.
- (5) Eventually, for each area we only need 1 pcs ADW310-D16-WF/C WiFi 1-phase Energy Meter.

2. Devices Deployment Plan - [1-phase, Separate, WiFi based Solution]

Area #1- Power Circuit (1-phase) #1:

- 1* ADW310-D16-WF/C WiFi 1-phase Energy Meter [For monitoring Power Circuit #1 & WiFi Upstream]

-
-

Area #10 - Power Circuit (1-phase) #10:

- 1* ADW310-D16-WF/C Wireless WiFi Energy Meter [For monitoring Power Circuit #10 & WiFi Upstream]

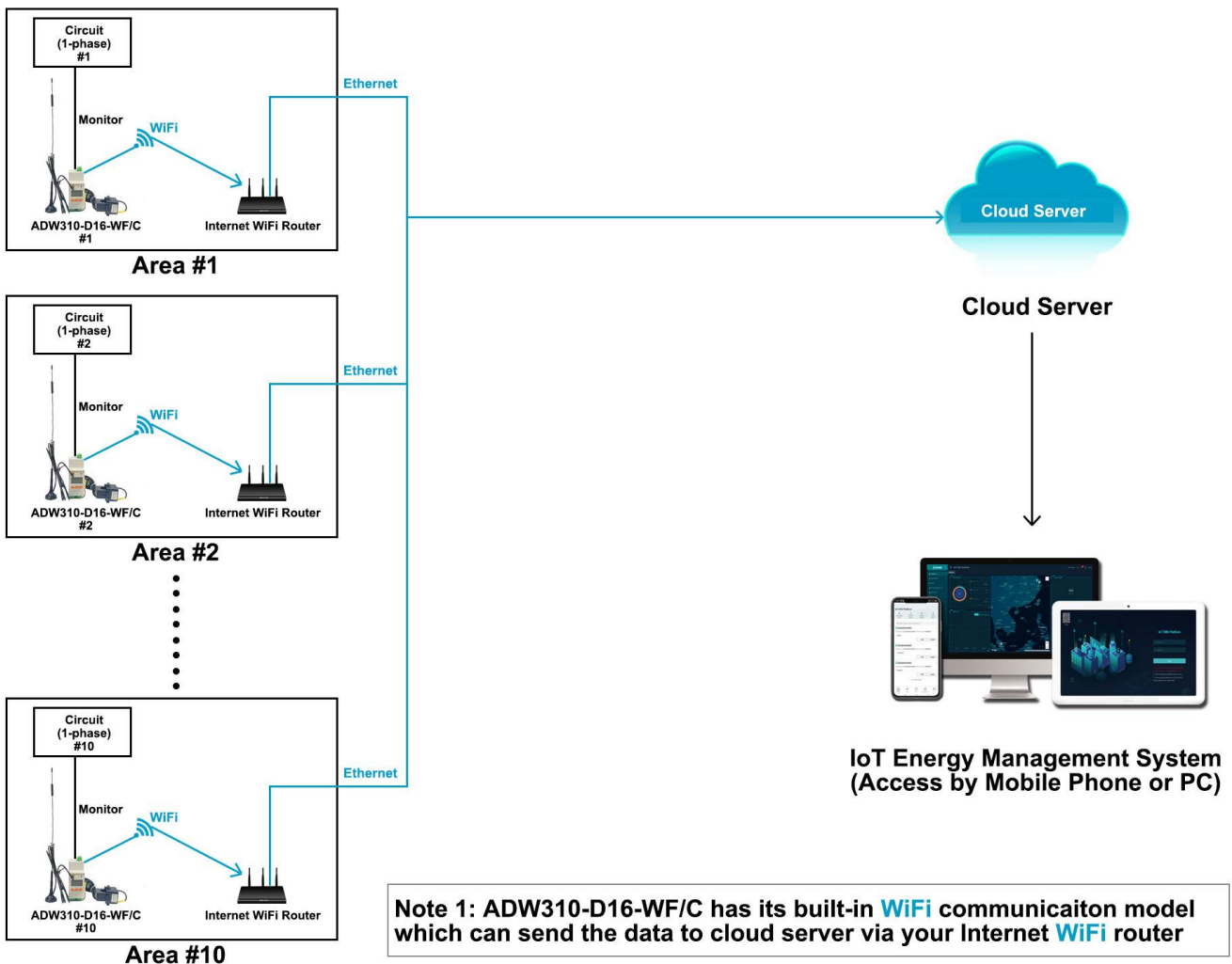

3. Communication Structure&Logic - [1-phase, Separate, WiFi based Solution]

- (1) WiFi Communication could be served as one of the final data upstream methods by sending the data to cloud server deployed in Internet via your WiFi Internet Router so that Acrel IoT System could be interact with these data collected by bottom metering devices like Energy Meter
- (2) ADW310-D16-WF/C Wireless WiFi 1-phase Energy Meter has a built-in WiFi communication module which allow it to directly send data to your Internet WiFi Router using MQTT and MODBUS-TCP protocol without using a extra WiFi IoT Gateway. Then your WiFi router will send the data further to internet for a final data upstreaming.
- (3) In the factory manufacturing stage, we can set the WiFi configuration (WiFi account and password) in ADW310-D16-WF/C so that users normally don't need to set WiFi configuration again.
- (4) ADW310-D16-WF/C also have a RS485 communication normally used for devices adjustment with Acrel ADW310 adjustment software. For example, setting like WiFi configuration could be done.

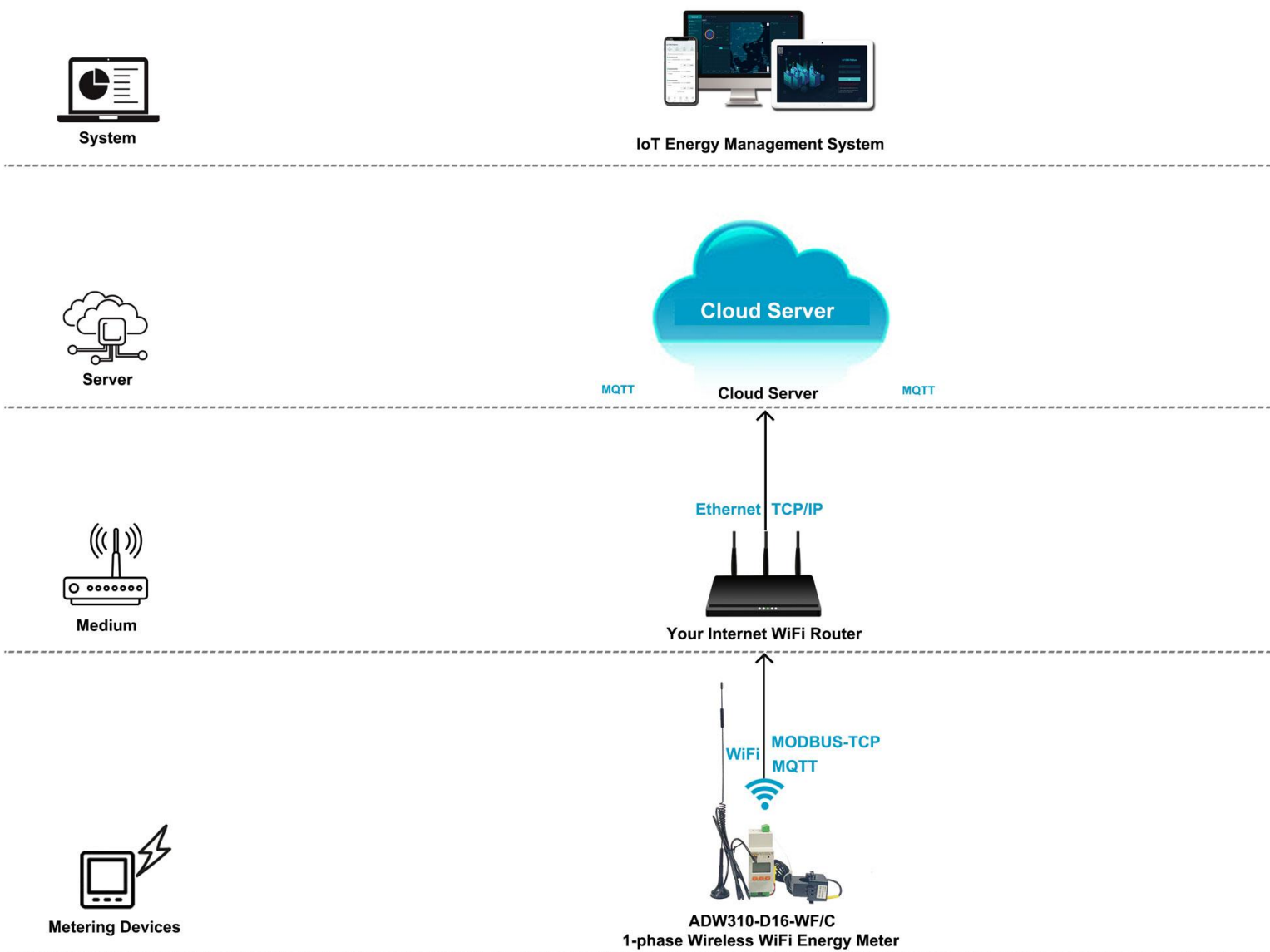



4. Hardware Devices Overview - [1-phase, Separate, WiFi based Solution]**Model 1: ADW310-Dxx-WF/C WiFi 1-phase IoT Energy Meter**

- Monitoring: Up to 1 circuits 3-phase [AC Metering]
- Wireless Comms.: WiFi [MQTT, MODBUS Protocol]
- Wired Comms.: RS485 [MODBUS-RTU Protocol]
- Rated Current: 3x1(6)A AC [via -/5A CTs.]
- Rated Voltage: Up to 220~264Vac L-N
- Certificate&Standard: CE

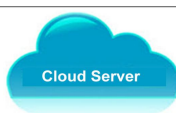

4. Overall Model Selection & Quotation - [1-phase, Separate, WiFi based Solution]

(1) This Quotation doesn't include freight charge. To gain a complete quotation, please refer the actual quantity that you want to request for the actual order, once we receiving it. We will issue a Official Proforma Invoice with Acrel Stamps on it for later procedure.

System Software					
Name	Description	System Price	Remark (Choose Host Service or Buy-out Service after 3-month Free Trial of Cloud IoT System)		
 Acrel Cloud IoT Energy Management System	1. System support all the meters across the country whose data has been sent to cloud server through 4G, WiFi or Ethernet . 2. Remote meter reading and data collection. 3. Provide IoT APP for mobile phone side and IoT WEB for PC side. 4. Generate energy data report of daily, monthly and annually period with year-on-year and period-on-period energy analysis. 5. Provide various alarm function to ensure a stable operation of the system and protect your property. 6. Offer 3-month free trial of system with full technical support as for a test phase or pilot project.	\$0 (recommended in pilot project)	3-month Free Trail (Users don't need to rent a cloud server)		
		\$xxx/Year (For 10 Points) (Price for Host Service Only, recommended in pilot project)	\$xx to buy Hosting Service for 1 monitoring points connected to the system 1 year (Users don't need to rent a cloud server)		
		\$xxxx/Permanent (Limitless Points) (Price for Buy-out Service Only, recommended in late project)	1-time charging of \$xxxx for Buy-out Service of permanent use (Limitless monitoring points and a cloud server need to be rent by users)		
Cloud Server					
Name	Description	Server Renting Price (For Reference Only)	Remark		
 Cloud Server	1. Cloud Server could be rent on the cloud server provider like Amazon Cloud. 2. Users of Cloud IoT Energy Management System only need to rent cloud server when they choose buy-out service of our Cloud IoT System . And if they are using hosting service or 3-month free trial of our Cloud IoT System, we will use our own cloud server which has been rent on Amazon so that users don't need to rent a cloud server. 3. The quotation of Cloud Server is only a reference price that we have rent on Amazon Cloud.	According to Specs of Rented Cloud Server	Below cloud server specs could support 1000-2000 monitorings points connected to the system (Server: 8 core 16G Operation System: windows server 2016)		
WiFi Wireless Energy Meter					
Overview Picture	USAGE & MODULE NAME	DESCRIPTION & SPECIFICATION	QUANTITY	FOB UNIT PRICE (USD)	AMOUNT (USD)
	1-phase WiFi Wireless Energy Meter ADW310-D16-WF/C	Communication: WiFi (MODBUS-TCP, MQTT) & RS485 (MODBUS-RTU) Rated Voltage: 220~264Vac L-N Rated Current: 20(100)A AC (via paired external CTs)	10 pcs	\$ (Including both Energy meter and External CTs)	
	Paired 1* External Split-core Current Transformer	Current Ratio: 100A/25mA AC Aperture: φ16mm Application: Paired with ADW310-D16-WF/C for current input	10 pcs		