

# RED-EMC Test Report

Client Name : Acrel Co., Ltd.  
Address : No.253, Yulv Road, Jiading District, Shanghai, China  
Product Name : Energy Meter  
Date : Apr. 19, 2022

**Shenzhen Anbotek Compliance Laboratory Limited**



# Contents

1. General Information.....	5
1.1. Client Information.....	5
1.2. Description of Device (EUT).....	5
1.3. Auxiliary Equipment Used During Test.....	7
1.4. Description of Test Modes.....	7
1.5. Test Equipment List.....	8
1.6. Description of Test Facility.....	11
1.7. Performance Criteria.....	11
2. Summary of Test Results.....	18
3. Emission Test.....	19
3.1. Conducted Emission Test at Main Ports.....	19
3.1.1. Test Standard and Limit.....	19
3.1.2. Test Setup.....	20
3.1.3. Test Procedure.....	20
3.1.4. Test Data.....	20
3.2. Radiated Emission Test.....	23
3.2.1. Test Standard and Limit.....	23
3.2.2. Test Setup.....	24
3.2.3. Test Procedure.....	24
3.2.4. Test Data.....	25
3.3. Harmonic Current Emissions.....	29
3.3.1. Test Standard and Limit.....	29
3.3.2. Test Setup.....	29
3.3.3. Test Procedure.....	29
3.3.4. Test Data.....	30
3.4. Voltage Fluctuations and Flicker.....	31
3.4.1. Test Standard and Limit.....	31
3.4.2. Test Setup.....	31
3.4.3. Test Procedure.....	31
3.4.4. Test Data.....	32
4. Immunity Test.....	33
4.1. Electrostatic Discharge Test.....	34
4.1.1. Test Standard and Specification.....	34
4.1.2. Test Setup.....	34
4.1.3. Test Procedure.....	35
4.1.4. Test Data.....	36
4.2. Radiated, RF Electromagnetic Fields Test.....	37
4.2.1. Test Standard and Specification.....	37
4.2.2. Test Setup.....	37

4.2.3. Test Procedure.....	37
4.2.4. Test Data.....	38
4.3. Fast Transients, Common Mode Test.....	39
4.3.1. Test Standard and Specification.....	39
4.3.2. Test Setup.....	39
4.3.3. Test Procedure.....	39
4.3.4. Test Data.....	40
4.4. Surges Test.....	41
4.4.1. Test Standard and Specification.....	41
4.4.2. Test Setup.....	41
4.4.3. Test Procedure.....	41
4.4.4. Test Data.....	42
4.5. Radio Frequency, Common Mode Test.....	44
4.5.1. Test Standard and Specification.....	44
4.5.2. Test Setup.....	44
4.5.3. Test Procedure.....	44
4.5.4. Test Data.....	45
4.6. Voltage Dips and Interruptions.....	47
4.6.1. Test Standard and Specification.....	47
4.6.2. Test Setup.....	47
4.6.3. Test Procedure.....	47
4.6.4. Test Data.....	48
APPENDIX I -- TEST SETUP PHOTOGRAPH.....	49
APPENDIX II -- EXTERNAL PHOTOGRAPH.....	54
APPENDIX III -- INTERNAL PHOTOGRAPH.....	58





# TEST REPORT

Applicant : Acrel Co., Ltd.  
Manufacturer : Jiangsu Acrel Electrical Manufacturing. Co., Ltd.  
Product Name : Energy Meter  
Model No. : ADW300, ADW300-WF, ADW300-WIFI, ADW300-4GHW, ADW300-FGHW,  
ADW300-Lora, ADW350, ADW400, ADW200, ADW210, ADW220, ADW500  
Trade Mark : Acrel  
Rating(s) : Input: AC 3x57.7/100V, 3x230/400V, AC 3x1(6)A

**Test Standard(s) : ETSI EN 301 489-1 V2.2.3 (2019-11)**  
**Final draft ETSI EN 301 489-3 V2.2.0 (2021-11)**  
**ETSI EN 301 489-17 V3.2.4 (2020-09)**  
**ETSI EN 301 489-52 V1.2.1 (2021-11)**

The device described above is tested by Shenzhen Anbotek Compliance Laboratory Limited to determine the maximum emission levels emanating from the device and the severe levels of the device can endure and its performance criterion. The measurement results are contained in this test report and Shenzhen Anbotek Compliance Laboratory Limited is assumed full of responsibility for the accuracy and completeness of these measurements. Also, this report shows that the EUT (Equipment Under Test) is technically compliant with the EN 301 489-1, EN 301 489-3, EN 301 489-17, EN 301 489-52 requirements.

This report applies to above tested sample only and shall not be reproduced in part without written approval of Shenzhen Anbotek Compliance Laboratory Limited.

Date of Receipt

Mar. 22, 2022

Date of Test

Mar. 22~Apr. 12, 2022

Prepared By



(TuTu Hong)

Approved &amp; Authorized Signer



(Kingkong Jin)

## 1. General Information

### 1.1. Client Information

Applicant	:	Acrel Co., Ltd.
Address	:	No.253, Yulv Road, Jiading District, Shanghai, China
Manufacturer	:	Jiangsu Acrel Electrical Manufacturing. Co., Ltd.
Address	:	No.5, Dongmeng Road, Nanzha Street, Jiangyin City, Jiangsu Province, China
Factory	:	Jiangsu Acrel Electrical Manufacturing. Co., Ltd.
Address	:	No.5, Dongmeng Road, Nanzha Street, Jiangyin City, Jiangsu Province, China

### 1.2. Description of Device (EUT)

Product Name	:	Energy Meter	
Model No.	:	ADW300, ADW300-WF, ADW300-WIFI, ADW300-4GHW, ADW300-FGHW, ADW300-Lora, ADW350, ADW400, ADW200, ADW210, ADW220, ADW500 (Note: All samples are the same except the model number, so we prepare "ADW300" for test only.)	
Trade Mark	:	Acrel	
Test Power Supply	:	AC 230V, 50Hz	
Test Sample No.	:	1-2-1(Normal Sample), 1-2-2(Engineering Sample)	
Product Description	:	Operation Frequency:	SRD: 868.5MHz WiFi 2.4G 802.11b/g/n(HT20): 2412~2472MHz LTE-FDD: Band3: 1710-1785 MHz (TX); 1805-1880 MHz (RX) Band8: 880-915 MHz (TX); 925-960 MHz (RX) LTE-TDD: Band38: 2570-2620 MHz (TX & RX) Band40: 2300-2400 MHz (TX & RX)
		Modulation Type:	SRD: GFSK WiFi 2.4G: CCK, DQPSK, DBPSK for DSSS 64QAM, 16QAM, QPSK, BPSK for OFDM LTE: QPSK, 16QAM
		Number of Channel:	SRD: 1 Channels WiFi 2.4G 802.11b/g/n(HT20): 13 Channels
		Antenna Type:	External Antenna
		Antenna Gain(Peak):	SRD: 2dBi (Provided by customer) WiFi 2.4G: 2dBi (Provided by customer) LTE Band 3/8/38/40: 2dBi (Provided by customer)
		Hardware version :	V1.04

	Software version :	V1.10
	Adapter:	N/A

**Remark:** 1) For a more detailed features description, please refer to the manufacturer's specifications or the User's Manual.



**1.3. Auxiliary Equipment Used During Test**

N/A	
-----	--

**1.4. Description of Test Modes**

To investigate the maximum EMI emission characteristics generates from EUT, the test system was pre-scanning tested base on the consideration of following EUT operation mode or test configuration mode which possible have effect on EMI emission level. Each of these EUT operation mode(s) or test configuration mode(s) mentioned above was evaluated respectively.

Pretest Mode	Description
Mode 1	Working

For Conducted Emission	
Final Test Mode	Description
Mode 1	Working

For Radiated Emission	
Final Test Mode	Description
Mode 1	Working



**1.5. Test Equipment List****Conducted Emission Measurement**

Item	Equipment	Manufacturer	Model No.	Serial No.	Last Cal.	Cal. Interval
1.	L.I.S.N. Artificial Mains Network	Rohde & Schwarz	ENV216	100055	Oct. 22, 2021	1 Year
2.	Three Phase V-type Artificial Power Network	CYBERTEK	EM5040DT	E215040D T001	Jul 05, 2021	1 Year
3.	EMI Test Receiver	Rohde & Schwarz	ESCI	100627	Oct. 22, 2021	1 Year
4.	RF Switching Unit	Compliance Direction	RSU-M2	38303	Oct. 22, 2021	1 Year
5.	Software Name EZ-EMC	Ferrari Technology	ANB-03A	N/A	N/A	N/A
6.	Wideband Radio Communication Tester	Rohde & Schwarz	CMW 500	104209	Oct. 22, 2021	1 Year

**Radiated Emission Measurement**

Item	Equipment	Manufacturer	Model No.	Serial No.	Last Cal.	Cal. Interval
1.	EMI Test Receiver	Rohde & Schwarz	ESR26	101481	Oct. 22, 2021	1 Year
2.	Bilog Broadband Antenna	Schwarzbeck	VULB9163	VULB 9163-289	Oct. 22, 2021	2 Year
3.	Pre-amplifier	SONOMA	310N	186860	Oct. 22, 2021	1 Year
4.	Software Name EZ-EMC	Ferrari Technology	ANB-03A	N/A	N/A	N/A
5.	Preamplifier	SKET Electronic	BK1G18G30D	KD17503	Oct. 22, 2021	1 Year
6.	Double Ridged Horn Antenna	Instruments corporation	GTH-0118	351600	Oct. 22, 2021	2 Year
7.	Wideband Radio Communication Tester	Rohde & Schwarz	CMW 500	104209	Oct. 22, 2021	1 Year

**Harmonic and Flicker Measurement**

Item	Equipment	Manufacturer	Model No.	Serial No.	Last Cal.	Cal. Interval
1.	Programmable AC Power source	IVYTECH	APS-5005A	632734	Oct. 22, 2021	1 Year
2.	Harmonic and Flicker Analyzer	EMC-PARTNER	HMONICS 1000-1P	164	Oct. 22, 2021	1 Year
3.	Harmonics-1000	N/A	Ed.3.0+4.0	N.A	N/A	N/A
4.	Wideband Radio Communication Tester	Rohde & Schwarz	CMW 500	104209	Oct. 22, 2021	1 Year



Electrostatic Discharge Measurement

Item	Equipment	Manufacturer	Model No.	Serial No.	Last Cal.	Cal. Interval
1.	ESD Simulators	3Ctest	EDS-30T	ES0131505	Oct. 28, 2021	1 Year
2.	Wideband Radio Communication Tester	Rohde & Schwarz	CMW 500	104209	Oct. 22, 2021	1 Year

R/S Immunity Measurement

Item	Equipment	Manufacturer	Model No.	Serial No.	Last Cal.	Cal. Interval
1.	Signal Generator	Agilent	N5182A	MY48180656	Oct. 22, 2021	1 Year
2.	Amplifier	Micotoop	MPA-80-1000-250	MPA1903096	Oct. 22, 2021	1 Year
3.	Amplifier	Micotoop	MPA-1000-6000-100	MPA1903122	Oct. 22, 2021	1 Year
4.	Log-Periodic Antenna	Schwarzbeck	VULP9118E	00992	N/A	N/A
5.	Horn Antenna	Instruments corporation	GTH-0118	351600	Oct. 22, 2021	2 Year
6.	Power Sensor	Agilent	E9301A	MY41498906	Oct. 22, 2021	1 Year
7.	Power Sensor	Agilent	E9301A	MY41498088	Oct. 22, 2021	1 Year
8.	Power Meter	Agilent	E4419B	GB40202909	Oct. 22, 2021	1 Year
9.	Electric field Probe	Narda	EP 601	811ZX10351	Oct. 22, 2021	1 Year
10.	RS Test software	EMtrace	EM 3	V1.1.7	N/A	N/A
11..	Wideband Radio Communication Tester	Rohde & Schwarz	CMW 500	104209	Oct. 22, 2021	1 Year

Surge Measurement

Item	Equipment	Manufacturer	Model No.	Serial No.	Last Cal.	Cal. Interval
1.	Combined Wave Lightning Surge Simulator	3Ctest	CCS600	ES3771702	Jul. 05, 2021	1 Year
2.	Three Phase Power Coupling Network	3Ctest	SEPN69100T	ES0801757	Jul. 05, 2021	1 Year
3.	Telecom port surge generator	PMI	TW101	190411	May 13, 2021	1 Year
4.	Wideband Radio Communication Tester	Rohde & Schwarz	CMW 500	104209	Oct. 22, 2021	1 Year

## Electrical Fast Transient/Burst Immunity Measurement

Item	Equipment	Manufacturer	Model No.	Serial No.	Last Cal.	Cal. Interval
1.	Surge Generator	TESEQ	NSG 3060	1480	Oct. 22, 2021	1 Year
2.	CDN	TESEQ	CDN 3061	1408	Oct. 22, 2021	1 Year
3.	EFT-Clamp	PRIMA	EFT-Clamp	/	Oct. 22, 2021	1 Year
4.	Wideband Radio Communication Tester	Rohde & Schwarz	CMW 500	104209	Oct. 22, 2021	1 Year

## Injected Currents Susceptibility Measurement

Item	Equipment	Manufacturer	Model No.	Serial No.	Last Cal.	Cal. Interval
1.	C/S Conducted Immunity Test System	FRANKONIA	CIT-10	126A1196/2012	Oct. 22, 2021	1 Year
2.	CDN	FRANKONIA	CDN - M2+ M3	A2210178/2012	Oct. 22, 2021	1 Year
3.	6dB Attenuator	FRANKONIA	DAM 26W	1172202	Oct. 22, 2021	1 Year
4.	CIT-10	FRANKONIA	Version1.1.7	N/A	N/A	N/A
5.	EM-Clamp	FRANKONIA	EMCL-20	18101728-0103	May 17,2021	1 Year
6.	Wideband Radio Communication Tester	Rohde & Schwarz	CMW 500	104209	Oct. 22, 2021	1 Year

## Voltage Dips and Interruptions Measurement

Item	Equipment	Manufacturer	Model No.	Serial No.	Last Cal.	Cal. Interval
1.	CYCLE SAG Simulator	PRIMA	DRP61011AG	PR12046234	Oct. 22, 2021	1 Year
2.	Wideband Radio Communication Tester	Rohde & Schwarz	CMW 500	104209	Oct. 22, 2021	1 Year



## 1.6. Description of Test Facility

The test facility is recognized, certified, or accredited by the following organizations:

### FCC-Registration No.: 184111

Shenzhen Anbotek Compliance Laboratory Limited, EMC Laboratory has been registered and fully described in a report filed with the (FCC) Federal Communications Commission. The acceptance letter from the FCC is maintained in our files. Registration No. 184111.

### ISED-Registration No.: 8058A

Shenzhen Anbotek Compliance Laboratory Limited, EMC Laboratory has been registered and fully described in a report filed with the (ISED) Innovation, Science and Economic Development Canada. The acceptance letter from the ISED is maintained in our files. Registration 8058A.

### Test Location

Shenzhen Anbotek Compliance Laboratory Limited.

1/F, Building D, Sogood Science and Technology Park, Sanwei community, Hangcheng Street, Bao'an District, Shenzhen, Guangdong, China.518102

## 1.7. Performance Criteria

### 1.7.1. For EMS Test:

- √ A: Normal performance within the specification limits;
- √ B: Temporary degradation or loss of function or performance which is self-recoverable;
- √ C: Temporary degradation or loss of function or performance which requires operator intervention or system reset;
- √ D: Degradation or loss of function which is not recoverable due to damage of equipment (components) or software, or loss of data

Note: The manufacturer's specification may define effects on the EUT which may be considered insignificant, and therefore acceptable.

This classification may be used as a guide in formulating performance criteria, by committees responsible for generic, product and product-family standards, or as a framework for the agreement on performance criteria between the manufacturer and the purchaser, for example where no suitable generic, product or product-family standard exists.

### 1.7.2. For EN 301 489-3:

#### 1.7.2.1. Performance Criteria

In the table below:

- performance criterion A applies for immunity tests with phenomena of a continuous nature;
- performance criterion B applies for immunity tests with phenomena of a transient nature.

NOTE: Whether a phenomenon is considered transient, continuous or otherwise is indicated in the test



procedures

for the phenomenon in ETSI EN 301 489-1 [1], clause 9.

**Table 2: Performance Requirements**

Criterion	During test	After test
A	Operate as intended No loss of function No unintentional responses	Operate as intended No loss of function No degradation of performance No loss of stored data or user programmable functions
B	May show loss of function No unintentional responses	Operate as intended Lost function(s) shall be self-recoverable No degradation of performance No loss of stored data or user programmable functions

Where "operate as intended" or "no loss of function" is specified, the EUT shall demonstrate correct functioning as

described in clause 5.

Where the EUT has more than one mode of operation (see clause 4.5.2), an unplanned transition from one mode to

another is considered as an unintentional response. The EUT shall be tested in sufficient modes to confirm there are no

such unintentional responses.

### 1.7.3. For EN 301 489-17:

The performance criteria are:

- performance criteria A for immunity tests with phenomena of a continuous nature;
- performance criteria B for immunity tests with phenomena of a transient nature;
- performance criteria C for immunity tests with power interruptions exceeding a certain time.

The equipment shall meet the minimum performance criteria as specified in the following clauses.



**Table 1: Performance criteria**

Criteria	During test	After test
A	Shall operate as intended. (see note 1). Shall be no loss of function. Shall be no unintentional transmissions.	Shall operate as intended. Shall be no degradation of performance (see note 3). Shall be no loss of function. Shall be no loss of stored data or user programmable functions.
B	May show loss of function (one or more). May show degradation of performance (see note 2). Shall be no unintentional transmissions.	Functions shall be self-recoverable. Shall operate as intended after recovering. Shall be no degradation of performance (see note 3). Shall be no loss of stored data or user programmable functions.
C	May be loss of function (one or more).	Functions shall be recoverable by the operator. Shall operate as intended after recovering. Shall be no degradation of performance (see note 3).
<p>NOTE 1: Operate as intended during the test allows a level of degradation not below a minimum performance level specified by the manufacturer for the use of the apparatus as intended. In some cases the specified minimum performance level may be replaced by a permissible degradation of performance. If the minimum performance level or the permissible performance degradation is not specified by the manufacturer then either of these may be derived from the product description and documentation (including leaflets and advertising) and what the user may reasonably expect from the apparatus if used as intended.</p> <p>NOTE 2: Degradation of performance during the test is understood as a degradation to a level not below a minimum performance level specified by the manufacturer for the use of the apparatus as intended. In some cases the specified minimum performance level may be replaced by a permissible degradation of performance. If the minimum performance level or the permissible performance degradation is not specified by the manufacturer then either of these may be derived from the product description and documentation (including leaflets and advertising) and what the user may reasonably expect from the apparatus if used as intended.</p> <p>NOTE 3: No degradation of performance after the test is understood as no degradation below a minimum performance level specified by the manufacturer for the use of the apparatus as intended. In some cases the specified minimum performance level may be replaced by a permissible degradation of performance. After the test no change of actual operating data or user retrievable data is allowed. If the minimum performance level or the permissible performance degradation is not specified by the manufacturer then either of these may be derived from the product description and documentation (including leaflets and advertising) and what the user may reasonably expect from the apparatus if used as intended.</p>		

**Performance criteria for Continuous phenomena applied to Transmitters (CT)**

The performance criteria A shall apply. Tests shall be repeated with the EUT in standby mode (if applicable) to ensure that unintentional transmission does not occur. In systems using acknowledgement signals, it is recognized that an ACKnowledgement (ACK) or Not ACKnowledgement (NACK) transmission may occur, and steps should be taken to ensure that any transmission resulting from the application of the test is correctly interpreted.

**Performance criteria for Transient phenomena applied to Transmitters (TT)**

The performance criteria B shall apply, except for voltage dips of 100 ms and voltage interruptions of 5 000 ms duration, for which performance criteria C shall apply. Tests shall be repeated with the EUT in standby mode (if applicable) to ensure that unintentional transmission does not occur. In systems using acknowledgement signals, it is recognized that an acknowledgement (ACK) or not-acknowledgement (NACK) transmission may occur, and steps should be taken to ensure that any transmission resulting from the application of the test is correctly interpreted.



**Performance criteria for Continuous phenomena applied to Receivers (CR)**

The performance criteria A shall apply. Where the EUT is a transceiver, under no circumstances, shall the transmitter operate unintentionally during the test. In systems using acknowledgement signals, it is recognized that an ACK or NACK transmission may occur, and steps should be taken to ensure that any transmission resulting from the application of the test is correctly interpreted.

**Performance criteria for Transient phenomena applied to Receivers (TR)**

The performance criteria B shall apply, except for voltage dips of 100 ms and voltage interruptions of 5 000 ms duration for which performance criteria C shall apply. Where the EUT is a transceiver, under no circumstances, shall the transmitter operate unintentionally during the test. In systems using acknowledgement signals, it is recognized that an ACK or NACK transmission may occur, and steps should be taken to ensure that any transmission resulting from the application of the test is correctly interpreted.

**1.7.4. For EN 301 489-52:****1.7.4.1. GSM and DCS Performance Criteria**

The equipment shall meet the performance criteria specified in this clause and clauses 6.1.1 to 6.1.4, as appropriate.

Portable equipment intended for use whilst powered by the main battery of a vehicle shall additionally fulfil the applicable requirements set out in ETSI EN 301 489-1 [1], clauses 7.1 and 7.2 for mobile equipment.

Portable or mobile equipment powered by the AC mains shall additionally fulfil the applicable requirements of ETSI EN 301 489-1 [1], clauses 7.1 and 7.2 for radio and ancillary equipment for fixed use.

The establishment and maintenance of a communications link, the assessment of RXQUAL, and the assessment of the audio breakthrough by monitoring the speech output signal level, are used as performance criteria to ensure that all primary functions of the transmitter and receiver are evaluated during the immunity tests. In addition, the test shall also be performed in idle mode to ensure the transmitter does not unintentionally operate.

The maintenance of a communications link shall be assessed using an indicator which may be part of the test system or the EUT.

If an equipment is of a specialized nature, such that the performance criteria described in the following clauses are not appropriate, then the manufacturer shall declare, for inclusion in the test report, his own specification for an acceptable level of performance or degradation of performance during and/or after the immunity tests. The performance specification shall be included in the product description and documentation.

The performance criteria specified by the manufacturer shall give the same degree of immunity protection as called for in the following clauses.

**Performance criteria for Continuous phenomena applied to Transmitters (CT)**

A communication link shall be established at the start of the test, and maintained during the test, see clauses 4.2.3 and 4.2.4.



During the test, the uplink speech output level shall be at least 35 dB less than the previously recorded reference levels, when measured through an audio band pass filter of width 200 Hz, centred on 1 kHz (audio breakthrough check).

NOTE: When there is a high level background noise present the filter bandwidth can be reduced down to a minimum of 40 Hz.

At the conclusion of the test, the EUT shall operate as intended with no loss of user control functions or stored data, and the communication link shall have been maintained. In addition to confirming the above performance during a call, the test shall also be performed in idle mode, and the transmitter shall not unintentionally operate.

### **Performance criteria for Transient phenomena applied to Transmitters (TT)**

A communications link shall be established at the start of the test, see appropriate clauses 4.2 to 4.2.4. At the conclusion of each exposure the EUT shall operate with no user noticeable loss of the communication link. At the conclusion of the total test comprising the series of individual exposures, the EUT shall operate as intended with no loss of user control functions or stored data, as declared by the manufacturer, and the communication link shall have been maintained. In addition to confirming the above performance during a call, the test shall also be performed in idle mode, and the transmitter shall not unintentionally operate.

### **Performance criteria for Continuous phenomena applied to Receivers (CR)**

A communications link shall be established at the start of the test, see appropriate clauses 4.2 to 4.2.6. During the test, the RXQUAL of the downlink shall not exceed the value of three, measured during each individual exposure in the test sequence.

During the test, the downlink speech output level shall be at least 35 dB less than the previously recorded reference levels, when measured through an audio band pass filter of width 200 Hz, centred on 1 kHz (audio breakthrough check).

NOTE: When there is a high level background noise present the filter bandwidth can be reduced down to a minimum of 40 Hz. At the conclusion of the test, the EUT shall operate as intended with no loss of user control functions or stored data, and the communication link shall have been maintained.

### **Performance criteria for Transient phenomena applied to Receivers (TR)**

A communications link shall be established at the start of the test, see appropriate clauses 4.2. to 4.2.6. At the conclusion of each exposure the EUT shall operate with no user noticeable loss of the communication link. At the conclusion of the total test comprising the series of individual exposures, the EUT shall operate as intended with no loss of user control functions or stored data, as declared by the manufacturer, and the communication link shall have been maintained.



**1.7.4.2. CDMA Direct Spread (UTRA and E-UTRA) Performance Criteria**

The equipment shall meet the performance criteria specified in this clause and clauses 6.2.2 and 6.2.3 as appropriate.

The maintenance of a communications link shall be assessed by using an indicator, which may be part of the test system or the equipment under test. If an equipment is of a specialized nature, that the performance criteria described in the following clauses are not appropriate, then the manufacturer shall declare, for inclusion in the test report, his own specification for an acceptable level of performance or degradation of performance during and/or after testing, as required by the present document.

The performance criteria specified by the manufacturer shall give the same degree of immunity protection as called for in the following clauses. In addition, the test shall also be performed in idle mode to ensure the transmitter does not unintentionally operate. The requirements apply to all types of UTRA and E-UTRA (FDD or TDD) for the UE.

**Performance criteria for continuous phenomena**

A communication link shall be established at the start of the test, and maintained during the test, clauses 4.1 and 4.2. In the speech mode, the performance criteria shall be that the Up Link and Down Link speech output levels shall be at least 35 dB less than the recorded reference levels, when measured through an audio band pass filter of width 200 Hz, centred on 1 kHz (annex B).

NOTE: When there is a high level of background audio noise present, the filter bandwidth can be reduced down to a minimum of 40 Hz. At the conclusion of the test, the EUT shall operate as intended with no loss of user control functions or stored data, and the communication link shall have been maintained. In addition to confirming the above performance in traffic mode, the test shall be performed in idle mode, and the transmitter shall not unintentionally operate.

**UTRA**

In the data transfer mode, the performance criteria can be one of the following:

- if the BER (as referred in ETSI TS 134 109 [4]) is used, it shall not exceed 0,001 during the test sequence;
- if the BLER (as referred in ETSI TS 134 109 [4]) is used, it shall not exceed 0,01 during the test sequence.

The BLER calculation shall be based on evaluating the CRC on each transport block.

**E-UTRA**

In the data transfer mode, the performance criteria shall be that the throughput shall be  $\geq 95$  % of the maximum throughput of the reference measurement channel as specified in annex C in ETSI TS 136 101 [9] with parameters specified in tables 7.3.1-1 and 7.3.1-2 in ETSI TS 136 101 [9] during the test sequence.

**Performance criteria for Transient phenomena**

A communications link shall be established at the start of the test, clauses 4.1 and 4.2.



At the conclusion of each exposure the EUT shall operate with no user noticeable loss of the communication link. At the conclusion of the total test comprising the series of individual exposures, the EUT shall operate as intended with no loss of user control functions or stored data, as declared by the manufacturer, and the communication link shall have been maintained. In addition to confirming the above performance in traffic mode, the test shall also be performed in idle mode, and the transmitter shall not unintentionally operate.





## 2. Summary of Test Results

EMC Emission				
Test Items	Standard	Basic Standard	Limit	Results
Conducted Emission	ETSI EN 301 489-1 V2.2.3 Clause 8.3 & 8.4	EN 55032: 2015	Class B	PASS
Radiated Emission	ETSI EN 301 489-1 V2.2.3 Clause 8.2	EN 55032: 2015	Class B	PASS
Harmonic Current Emission	ETSI EN 301 489-1 V2.2.3 Clause 8.5	EN IEC 61000-3-2: 2019	Class A	N/A
Voltage Fluctuations & Flicker	ETSI EN 301 489-1 V2.2.3 Clause 8.6	EN 61000-3-3: 2013+A1:2019	/	PASS
EMC Immunity				
Test Items	Standard	Basic Standard	Performance Criteria	Results
Electrostatic Discharge	ETSI EN 301 489-1 V2.2.3 Clause 9.3	EN 61000-4-2:2009	B	PASS
RF Electromagnetic Field	ETSI EN 301 489-1 V2.2.3 Clause 9.2	EN 61000-4-3:2006 +A1:2008+A2:2010	A	PASS
Fast transients, common mode	ETSI EN 301 489-1 V2.2.3 Clause 9.4	EN 61000-4-4:2012	B	PASS
Surges	ETSI EN 301 489-1 V2.2.3 Clause 9.8	EN 61000-4-5: 2014+A1:2017	B	PASS
Radio frequency, common mode	ETSI EN 301 489-1 V2.2.3 Clause 9.5	EN 61000-4-6:2014	A	PASS
Volt. Interruptions Volt. Dips	ETSI EN 301 489-1 V2.2.3 Clause 9.7	EN 61000-4-11: 2014+A1:2017	B / C / C NOTE (3)	PASS
<b>NOTE:</b>				
	(1) "N/A" denotes test is not applicable in this Test Report			
	(2) Alternatively, for equipment intended to be used exclusively in an industrial environment or a telecommunication centre, the class A limits may be used.			
	(3) Voltage dip: 100% reduction – Performance Criteria B			
	Voltage dip: 100% reduction – Performance Criteria B			
	Voltage dip: 70% reduction – Performance Criteria C			
	Voltage Interruption: 0% Interruption – Performance Criteria C			

## 3. Emission Test

### 3.1. Conducted Emission Test at Main Ports

#### 3.1.1. Test Standard and Limit

Test Standard	ETSI EN 301 489-1 V2.2.3 Clause 8.3 & 8.4
Basic Standard	EN 55032: 2015

Limits for conducted emissions

Test Limit	Frequency	Maximum RF Line Voltage (dBuV)	
		Quasi-peak Level	Average Level
	150kHz~500kHz	66 ~ 56 *	56 ~ 46 *
	500kHz~5MHz	56	46
	5MHz~30MHz	60	50

**Remark:** \*Decreasing linearly with logarithm of the frequency.

Limits for conducted emissions of equipment  
intended to be used in telecommunication centre and industrial environment

Test Limit	Frequency	Maximum RF Line Voltage (dBuV)	
		Quasi-peak Level	Average Level
	150kHz~500kHz	79	66
	500kHz~30MHz	73	60



### 3.1.2. Test Setup

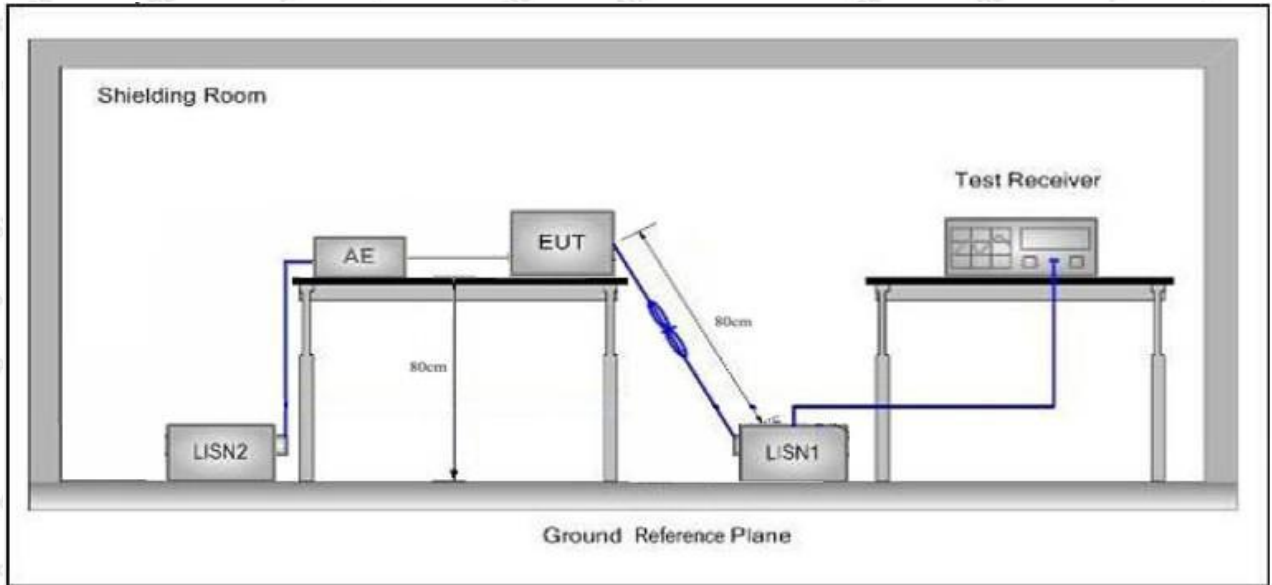

### 3.1.3. Test Procedure

The EUT system is connected to the power mains through a line impedance stabilization network (L.I.S.N.). This provides a 50ohm coupling impedance for the EUT system. Please refer the block diagram of the test setup and photographs. Both sides of AC line are checked to find out the maximum conducted emission. In order to find the maximum emission levels, the relative positions of equipment and all of the interface cables shall be changed according to ETSI EN 301 489-1 V2.2.3 & EN55032: 2015 on Conducted Emission Measurement.

The bandwidth of test receiver (ESCI) set at 9kHz.

The frequency range from 150kHz to 30MHz is checked.

For the actual test configuration, please refer to the related Item EUT Test Photos.

### 3.1.4. Test Data

PASS

The EUT should be compliance to the limit of Class B

Only the worst case data was showed in the report, please to see the following pages

### Conducted Emission Test Data

Test Site: 1# Shielded Room  
 Operating Condition: Mode 1  
 Test Specification: AC 230V, 50Hz  
 Comment: Live Line  
 Tem.: 22.8°C Hum.: 51%

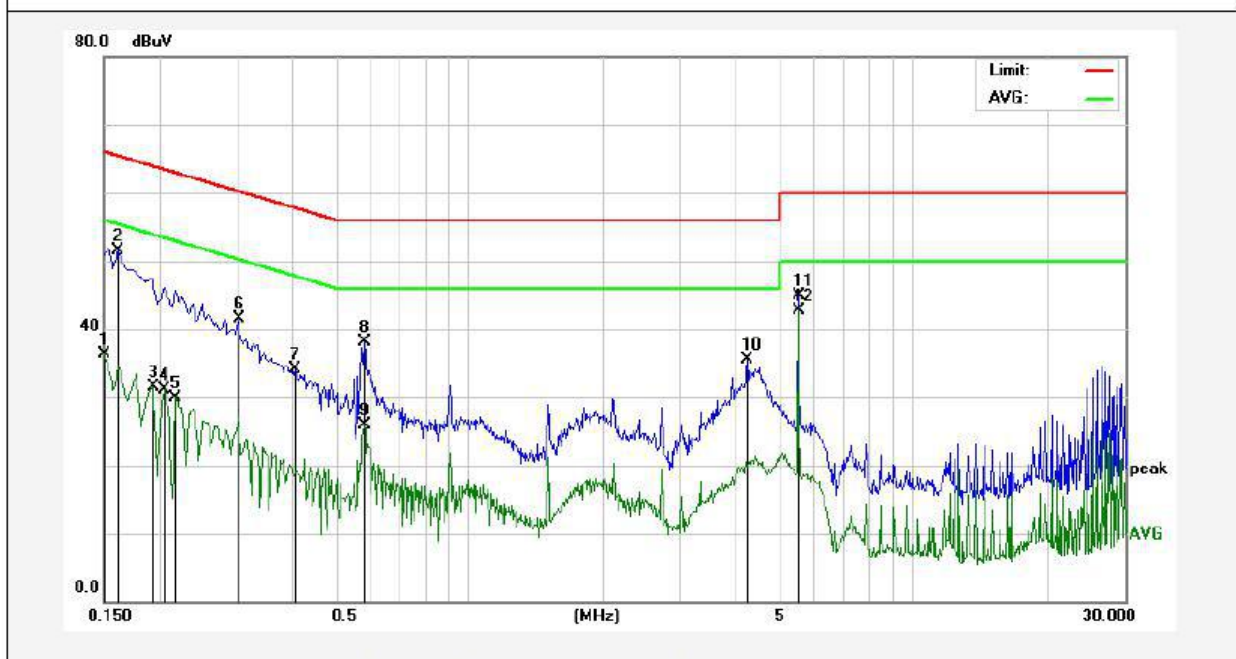

No.	Freq. (MHz)	Reading (dBuV)	Factor (dB)	Result (dBuV)	Limit (dBuV)	Over Limit (dB)	Detector	Remark
1	0.1500	36.19	0.11	36.30	55.99	-19.69	AVG	
2	0.1620	51.43	0.12	51.55	65.36	-13.81	QP	
3	0.1940	31.46	0.12	31.58	53.86	-22.28	AVG	
4	0.2060	30.99	0.12	31.11	53.36	-22.25	AVG	
5	0.2180	29.74	0.12	29.86	52.89	-23.03	AVG	
6	0.3020	41.46	0.13	41.59	60.19	-18.60	QP	
7	0.4060	33.91	0.11	34.02	57.73	-23.71	QP	
8	0.5820	37.99	0.15	38.14	56.00	-17.86	QP	
9	0.5820	25.74	0.15	25.89	46.00	-20.11	AVG	
10	4.2340	35.34	0.11	35.45	56.00	-20.55	QP	
11	5.5300	44.71	0.11	44.82	60.00	-15.18	QP	
12	5.5300	42.50	0.11	42.61	50.00	-7.39	AVG	



### Conducted Emission Test Data

Test Site: 1# Shielded Room  
 Operating Condition: Mode 1  
 Test Specification: AC 230V, 50Hz  
 Comment: Neutral Line  
 Tem.: 22.8°C Hum.: 51%

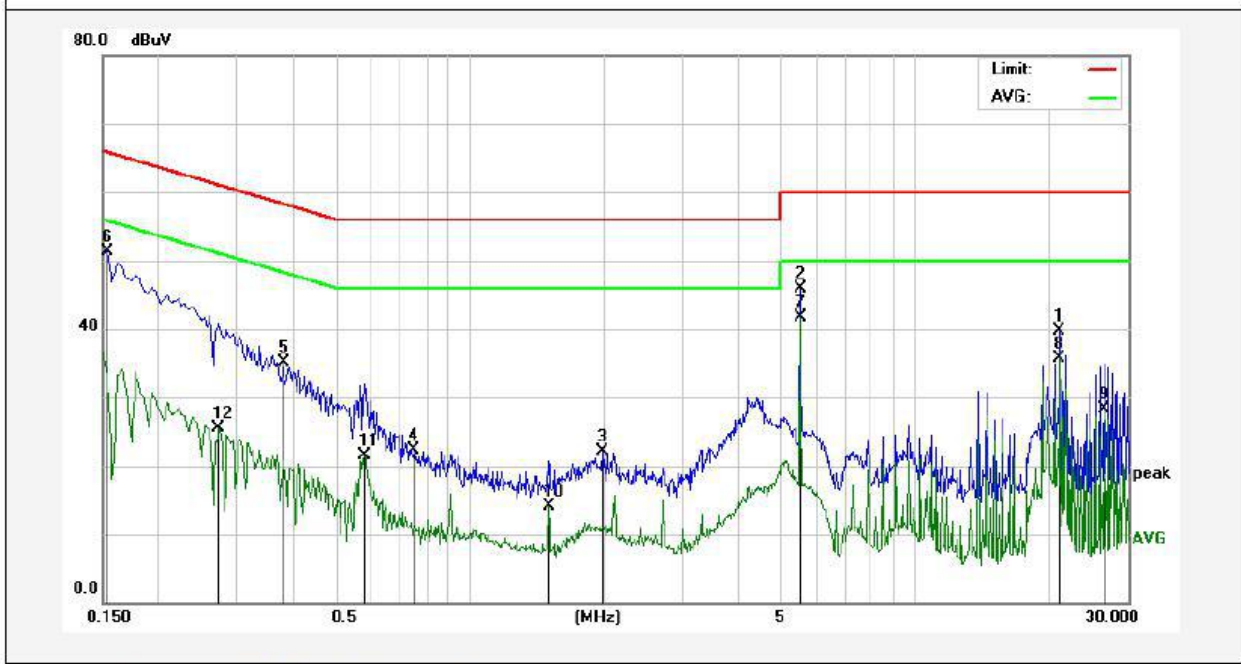

No.	Freq. (MHz)	Reading (dBuV)	Factor (dB)	Result (dBuV)	Limit (dBuV)	Over Limit (dB)	Detector	Remark
1	21.1299	39.45	0.19	39.64	60.00	-20.36	QP	
2	5.5298	45.84	0.11	45.95	60.00	-14.05	QP	
3	1.9819	21.90	0.12	22.02	56.00	-33.98	QP	
4	0.7500	22.06	0.15	22.21	56.00	-33.79	QP	
5	0.3820	35.02	0.11	35.13	58.23	-23.10	QP	
6	0.1539	51.22	0.12	51.34	65.78	-14.44	QP	
7	5.5298	41.65	0.11	41.76	50.00	-8.24	AVG	
8	21.1299	35.42	0.19	35.61	50.00	-14.39	AVG	
9	26.5620	28.10	0.23	28.33	50.00	-21.67	AVG	
10	1.5100	13.91	0.13	14.04	46.00	-31.96	AVG	
11	0.5819	21.28	0.15	21.43	46.00	-24.57	AVG	
12	0.2740	25.36	0.13	25.49	50.99	-25.50	AVG	

## 3.2. Radiated Emission Test

### 3.2.1. Test Standard and Limit

Test Standard	ETSI EN 301 489-1 V2.2.3 Clause 8.2
Basic Standard	EN 55032: 2015

#### Radiated Emission Test Limit (Below 1000MHz)

Frequency (MHz)	Limit (dB $\mu$ V/m)	
	Quasi-peak Level	
	Class B	Class A
30MHz~230MHz	40	50
230MHz~1000MHz	47	57

**Remark:** 1. The lower limit shall apply at the transition frequency. 2. The test distance is 3m.

#### Radiated Emission Test Limit (Above 1000MHz)

Frequency (MHz)	Limit (dB $\mu$ V/m)			
	Class B		Class A	
	Peak	Average	Peak	Average
1000 MHz -3000 MHz	70	50	76	56
3000 MHz -6000 MHz	74	54	80	60

**Remark:** 1. The lower limit applies at the transition frequency. 2. The test distance is 3m.

#### Radiated Emission Test Limit for FM Receivers

Frequency (MHz)	Limit (dB $\mu$ V/m)	
	Quasi-peak Level	
	Fundamental	Harmonics
30MHz~230MHz	60	52
230MHz~300MHz	60	52
300MHz~1000MHz	60	56

**Remark:** 1. The lower limit shall apply at the transition frequency. 2. The test distance is 3m.

#### Frequency Range of Radiated Measurement

Highest frequency generated or Upper frequency of measurement used in the device or on which the device operates or tunes (MHz)	Range (MHz)
Below 108	1000
108 – 500	2000
500 – 1000	5000
Above 1000	5th harmonic of the highest frequency or 6 GHz, whichever is lower



### 3.2.2. Test Setup

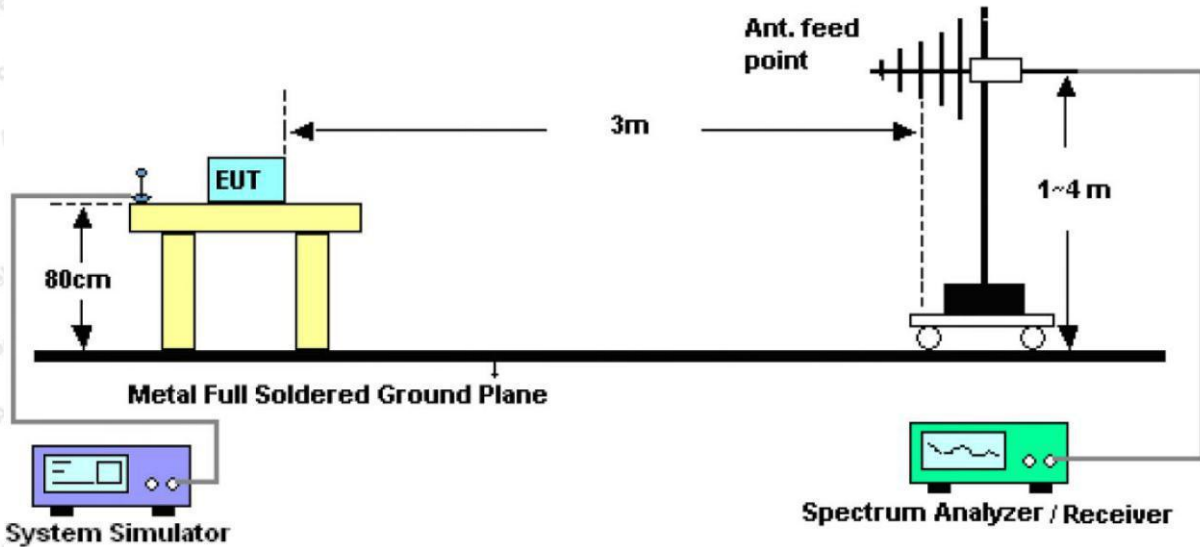

Figure 1. 30MHz to 1GHz

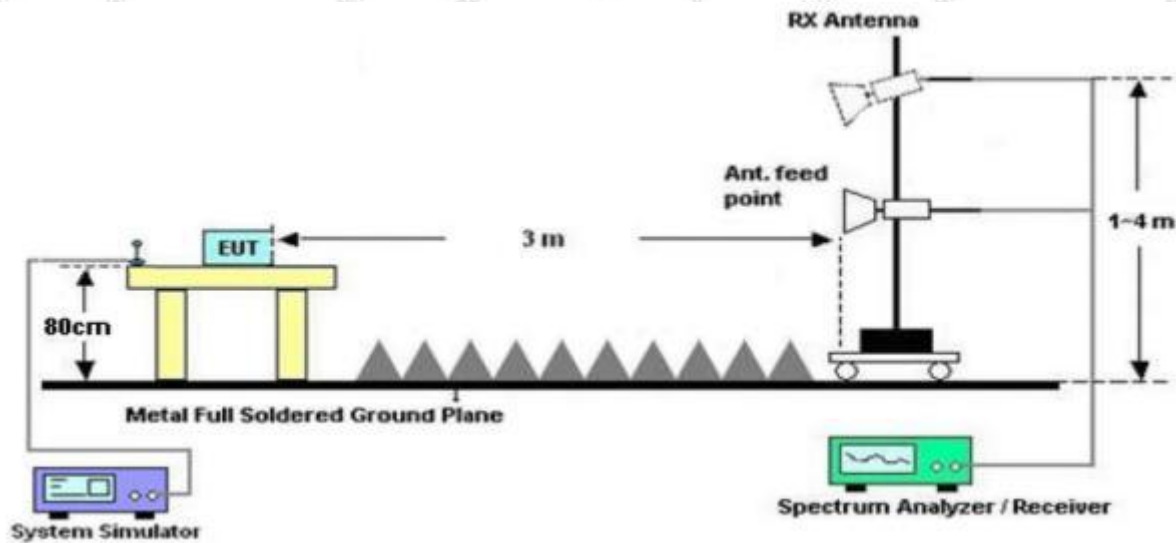

Figure 2. Above 1 GHz

### 3.2.3. Test Procedure

- 1) The measuring distance of at 3 m shall be used for measurements at frequency up to 1GHz. For frequencies above 1GHz, any suitable measuring distance may be used.
- 2) The EUT was placed on the top of a rotating table 0.8 meters above the ground at a 3 meter test site. The table was rotated 360 degrees to determine the position of the highest radiation.
- 3) The height of the equipment or of the substitution antenna shall be 0.8 m; the height of the test antenna shall vary between 1 m to 4 m. Both horizontal and vertical polarizations of the antenna are set to make the measurement.
- 4) The initial step in collecting radiated emission data is a spectrum analyzer peak detector mode pre-scanning the measurement frequency range. Significant peaks are then marked and then Quasi Peak detector mode re-measured.

5) The test-receiver system was set to quasi-peak detect function and specified bandwidth with maximum hold mode when the test frequency is below 1GHz.

The test receiver/spectrum was set to peak and average detect function and specified bandwidth with maximum hold mode when the test frequency is above 1GHz.

6) For the actual test configuration, please refer to the related Item –EUT Test Photos.

**Note:**

The resolution bandwidth of test receiver/spectrum analyzer is 120kHz for Quasi-peak detection (QP) at frequency below 1GHz.

The resolution bandwidth is 1MHz and video bandwidth of test receiver/spectrum analyzer is 3MHz for Peak/ Average detection at frequency above 1GHz.

### 3.2.4. Test Data

PASS

The EUT should be compliance to the limit of Class B

Only the worst case data was showed in the report, please to see the following pages



**Test Results (30~1000MHz)**

Test Mode: Mode 1

Temp.(°C)/Hum.(%RH): 22.7°C/49%RH

Polarization: Horizontal

Power Source: AC 230V, 50Hz

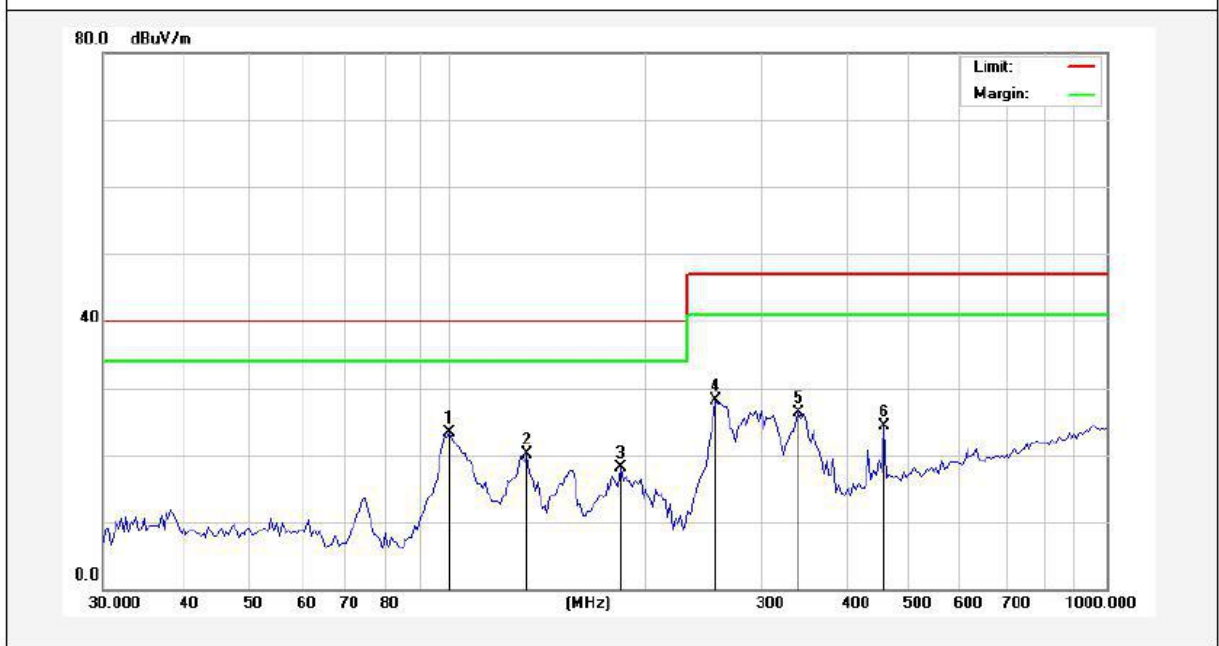

No.	Freq. (MHz)	Reading (dBuV)	Factor (dB/m)	Result (dBuV/m)	Limit (dBuV/m)	Over Limit (dB)	Detector	Height (cm)	degree (deg)	Remark
1	100.5806	40.35	-17.03	23.32	40.00	-16.68	QP			
2	131.9889	41.02	-20.92	20.10	40.00	-19.90	QP			
3	182.5592	37.28	-19.20	18.08	40.00	-21.92	QP			
4	254.7284	44.11	-15.95	28.16	47.00	-18.84	QP			
5	340.1847	40.11	-13.87	26.24	47.00	-20.76	QP			
6	458.3102	35.70	-11.33	24.37	47.00	-22.63	QP			

**Test Results (30~1000MHz)**

Test Mode: Mode 1

Temp.(°C)/Hum.(%RH): 22.7°C/49%RH

Polarization: Vertical

Power Source: AC 230V, 50Hz



No.	Freq. (MHz)	Reading (dBuV)	Factor (dB/m)	Result (dBuV/m)	Limit (dBuV/m)	Over Limit (dB)	Detector	Height (cm)	degree (deg)	Remark
1	33.0370	43.48	-18.04	25.44	40.00	-14.56	QP			
2	37.3509	42.35	-17.48	24.87	40.00	-15.13	QP			
3	101.4663	49.48	-17.14	32.34	40.00	-7.66	QP			
4	129.6950	50.71	-20.77	29.94	40.00	-10.06	QP			
5	275.6399	41.59	-15.45	26.14	47.00	-20.86	QP			
6	458.3102	34.55	-11.33	23.22	47.00	-23.78	QP			



**Test Results (1GHz~6GHz)**

Frequency (MHz)	Read Level (dBuV)	Factor (dB/m)	Level (dBuV/m)	Limit (dBuV/m)	Over Limit (dB)	Pol.	Detector
1307.04	54.73	-2.35	52.39	70.00	-17.61	H	PEAK
1813.96	51.35	-2.86	48.49	70.00	-21.51	H	PEAK
2288.40	45.83	-4.40	41.43	70.00	-28.57	H	PEAK
4195.24	45.14	-5.26	39.88	74.00	-34.12	H	PEAK
4533.16	53.15	-4.47	48.69	74.00	-25.31	H	PEAK
5068.41	45.29	-5.66	39.62	74.00	-34.38	H	PEAK
1307.04	42.28	-2.35	39.93	50.00	-10.07	H	AVG
1813.96	44.58	-2.86	41.73	50.00	-8.27	H	AVG
2288.40	39.65	-4.40	35.26	50.00	-14.74	H	AVG
4195.24	40.01	-5.26	34.75	54.00	-19.25	H	AVG
4533.16	44.54	-4.47	40.07	54.00	-13.93	H	AVG
5068.41	37.65	-5.66	31.98	54.00	-22.02	H	AVG
1594.33	45.90	-3.08	42.82	70.00	-27.18	V	PEAK
1900.71	51.84	-2.44	49.40	70.00	-20.60	V	PEAK
2002.55	55.72	-4.15	51.58	70.00	-18.42	V	PEAK
4078.66	46.77	-4.75	42.02	74.00	-31.98	V	PEAK
4617.69	45.64	-5.34	40.29	74.00	-33.71	V	PEAK
4818.69	53.92	-5.45	48.46	74.00	-25.54	V	PEAK
1594.33	40.79	-3.08	37.71	50.00	-12.29	V	AVG
1900.71	41.80	-2.44	39.36	50.00	-10.64	V	AVG
2002.55	39.49	-4.15	35.34	50.00	-14.66	V	AVG
4078.66	42.65	-4.75	37.90	54.00	-16.10	V	AVG
4617.69	43.20	-5.34	37.85	54.00	-16.15	V	AVG
4818.69	43.43	-5.45	37.97	54.00	-16.03	V	AVG

Remark:

1. Level =Read level + Factor

### 3.3. Harmonic Current Emissions

#### 3.3.1. Test Standard and Limit

Test Standard	ETSI EN 301 489-1 V2.2.3 Clause 8.5
Basic Standard	EN IEC 61000-3-2: 2019
Test Limit	Please to refer to the clause 7 of standard EN IEC 61000-3-2: 2019.

#### 3.3.2. Test Setup

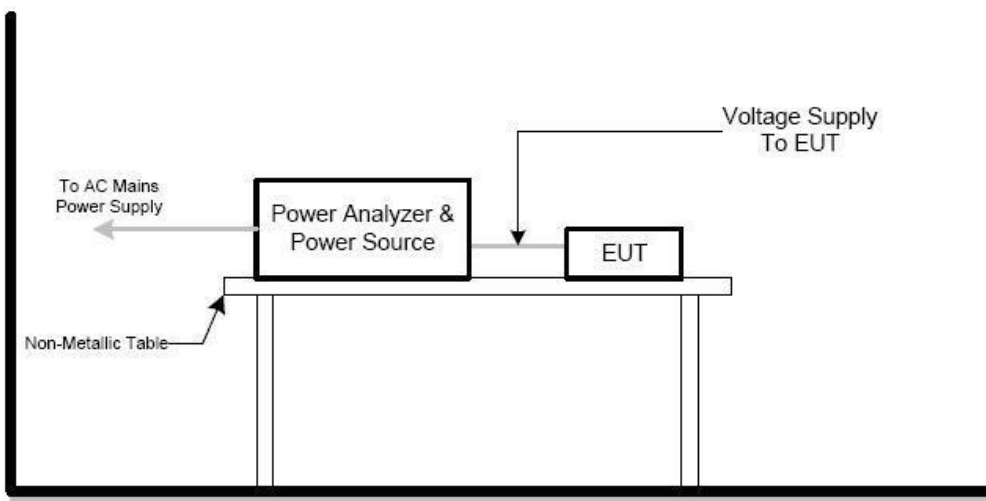

#### 3.3.3. Test Procedure

- 1) The EUT was placed on the top of a wooden table 0.8 meters above the ground and operated to produce the maximum harmonic components under normal operating conditions.
- 2) The classification of EUT is according to section 5 of EN IEC 61000-3-2: 2019. The EUT is classified as follows:
  - Class A: Balanced three-phase equipment, Household appliances excluding equipment as Class D, Tools excluding portable tools, Dimmers for incandescent lamps, audio equipment, equipment not specified in one of the three other classes.
  - Class B: Portable tools; Arc welding equipment which is not professional equipment.
  - Class C: Lighting equipment.
  - Class D: Equipment having a specified power less than or equal to 600W of the following types: Personal computers and personal computer monitors and television.
- 3) The correspondent test program of test instrument to measure the current harmonics emanated from EUT is chosen. The measure time shall be not less than the time necessary for the EUT to be exercised.
- 4) For the actual test configuration, please refer to the related item –EUT Test Photos.



### 3.3.4. Test Data

The active input power of the EUT is less than 75W. Therefore, according to EN 61000-3-2, no limits are necessary.

## 3.4. Voltage Fluctuations and Flicker

### 3.4.1. Test Standard and Limit

Test Standard	ETSI EN 301 489-1 V2.2.3 Clause 8.6
Basic Standard	EN 61000-3-3: 2013+A1:2019

Voltage Fluctuation and Flicker Test Limit

Test Items	Limits
Pst	1.0
Plt	0.65
dc	3.3%
dmax	4.0%
dt	Not exceed 3.3% for 500ms

### 3.4.2. Test Setup

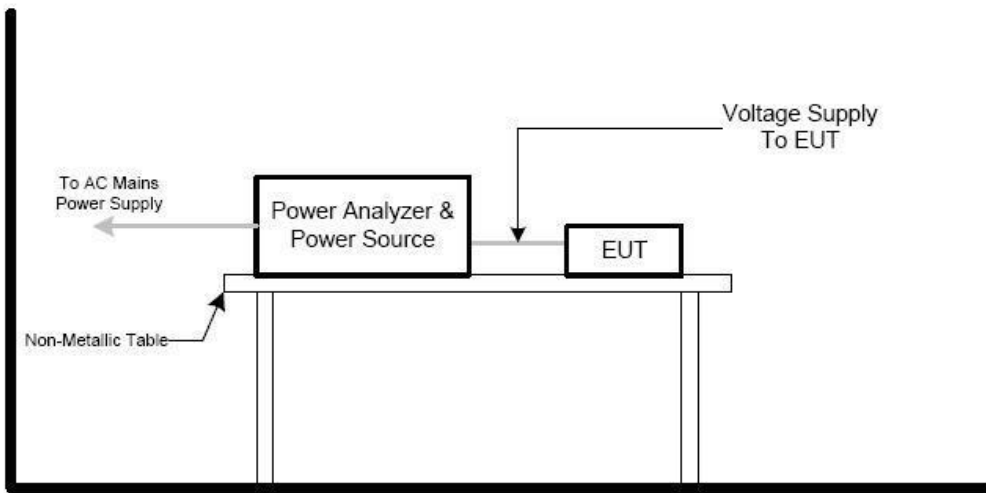

### 3.4.3. Test Procedure

- 1) Tests was performed according to the Test Conditions/Assessment of Voltage Fluctuations specified in Clause 5.0/6.0 of IEC555-3 and/or Clause 6.0/4.0 of IEC/EN 61000-3-3 depend on which standard adopted for compliance measurement.
- 2) All types of harmonic current and/or voltage fluctuation in this report are assessed by direct measurement using flicker-meter.
- 3) For the actual test configuration, please refer to the related Item –EUT Test Photos.



**3.4.4. Test Data**

Please to see the following pages

Standard: EN 61000-3-3      Temp.(°C)/Hum.(%RH): 24.3°C/55%RH  
 Test Mode: Mode 1      Power Source: AC 230V, 50Hz

**EMC PARTNER AG , Laufen**  
Flicker Emission IEC 61000-4-15 for 230V/50Hz

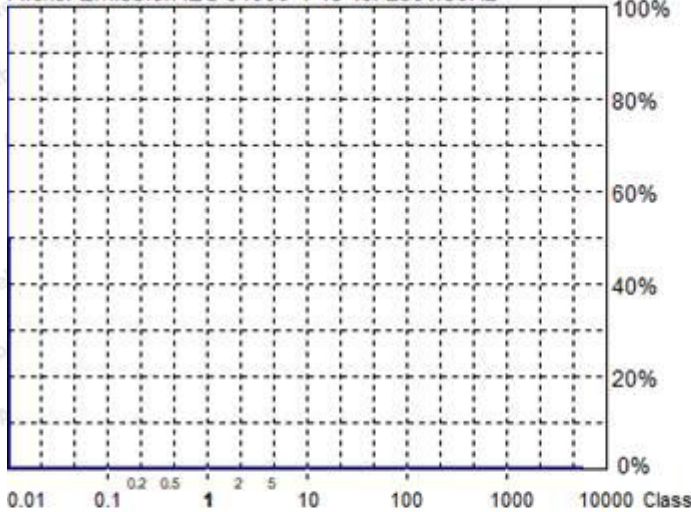

<b>Actual Flicker (Fli):</b>	<b>0.00</b>
<b>Short-term Flicker (Pst):</b>	<b>0.07</b>
Limit (Pst):	1.00
<b>Long-term Flicker (Plt):</b>	<b>0.00</b>
Limit (Plt):	0.65
<b>Maximum Relative Volt. Change (dmax):</b>	<b>0.00%</b>
Limit (dmax):	4.00%
<b>Relative Steady-state Voltage Change (dc):</b>	<b>0.00%</b>
Limit (dc):	3.00%
<b>Tmax 3.00% (dt):</b>	<b>0.00ms</b>
Limit (dt>Lim):	200ms

Flicker Emission - IEC 61000-3-3 , EN 61000-3-3

Urms = 229.7 V      P = 0.890 W      Range: 0.25 A  
 Irms = 0.011 A      pf = 0.345      V-nom: 230 V

**Test aborted, Result: PASSED**

HAR-1000 EMC Partner

Full Bar : Actual Values  
 Empty Bar : Maximum Values  
 Circles : Average Values  
 Blue : Current , Green : Voltage , Red : Failed

Urms = 229.7V      Freq = 50.000      Range: 0.25 A  
 Irms = 0.011A      Ipk = 0.036A      cf = 3.163  
 P = 0.890W      S = 2.580VA      pf = 0.345

Test - Time : 10 x 1min = 10min ( 100 %)

LIN (Line Impedance Network) : L: 0.24ohm +j0.15ohm N: 0.16ohm +j0.10ohm

Limits : Plt : 0.65      Pst : 1.00  
 dmax : 4.00 %      dc : 3.00 %  
 dtLim: 3.00 %      dt>Lim: 200ms

Test aborted, Result: PASSED

	dmax [%]	dc [%]	dt>Lim [ms]
1	0.000	0.000	0.000

## 4. Immunity Test

### General Performance Criteria

◆ Performance criteria for continuous phenomena applied to transmitters and receivers (CT/CR)

During and after the test, the apparatus shall continue to operate as intended. No degradation of performance or loss of function is allowed below a permissible performance level specified by the manufacturer when the apparatus is used as intended. In some cases this permissible performance level may be replaced by a permissible loss of performance.

During the test the EUT shall not unintentionally transmit or change its actual operating state and stored data.

If the minimum performance level or the permissible performance loss is not specified by the manufacturer, then either of these may be deduced from the product description and documentation and what the user may reasonably expect from the apparatus if used as intended.

◆ Performance criteria for transient phenomena applied to transmitters and receivers (TT/TR)

After the test, the apparatus shall continue to operate as intended. No degradation of performance or loss of function is allowed below a permissible performance level specified by the manufacturer, when the apparatus is used as intended. In some cases this permissible performance level may be replaced by a permissible loss of performance.

During the EMC exposure to an electromagnetic phenomenon, a degradation of performance is, however, allowed. No change of the actual mode of operation (e.g. unintended transmission) or stored data is allowed.

If the minimum performance level or the permissible performance loss is not specified by the manufacturer, then either of these may be deduced from the product description and documentation and what the user may reasonably expect from the apparatus if used as intended.

◆ Performance criteria for equipment which does not provide a continuous communication link

For radio equipment which does not provide a continuous communication link, the performance criteria described in CT/CR and TT/TR are not appropriate, then the manufacturer shall declare, for inclusion in the test report, his own specification for an acceptable level of performance or degradation of performance during and/or after the immunity tests.

The performance criteria specified by the manufacturer shall give the same degree of immunity protection as called for in CT/CR and TT/TR.

◆ Performance criteria for ancillary equipment tested on a stand alone basis

If ancillary equipment is intended to be tested on a stand alone basis, the performance criteria described in CT/CR and TT/TR are not appropriate, then the manufacturer shall declare, for inclusion in the test report, his own specification for an acceptable level of performance or degradation of performance during and/or after the immunity tests.

The performance criteria specified by the manufacturer shall give the same degree of immunity protection as called for in CT/CR and TT/TR.



## 4.1. Electrostatic Discharge Test

### 4.1.1. Test Standard and Specification

Test Standard	ETSI EN 301 489-1 V2.2.3 Clause 9.3
Basic Standard	EN 61000-4-2:2009
Discharge Impedance:	330 ohm / 150 pF
Performance Criterion:	CT/CR
Discharge Voltage:	Air Discharge: 2kV/4kV/8kV Contact Discharge: 2kV/4kV (Direct/Indirect)
Polarity:	Positive & Negative
Number of Discharge:	Air Discharge: min. 20 times at each test point Contact Discharge: min. 200 times in total
Discharge Mode:	Single Discharge
Discharge Period:	1 second minimum

### 4.1.2. Test Setup

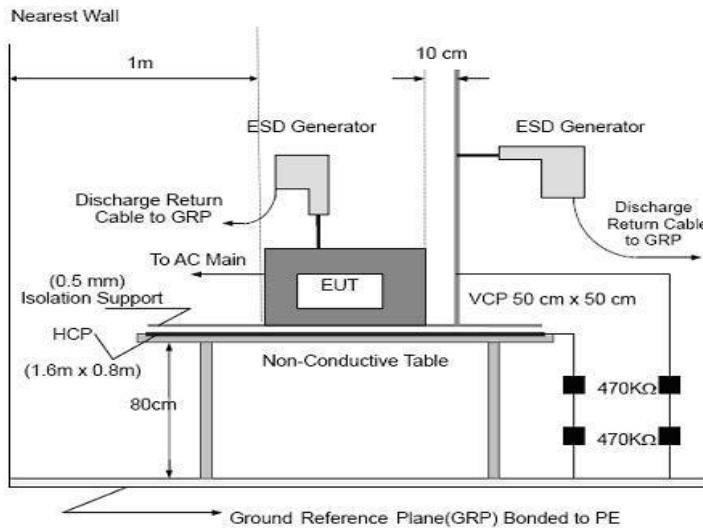

Note:

#### TABLE-TOP EQUIPMENT:

The configuration consisted of a wooden table 0.8 meters high standing on the Ground Reference Plane. The GRP consisted of a sheet of aluminum at least 0.25mm thick, and 2.5 meters square connected to the protective grounding system. A Horizontal Coupling Plane (1.6m x 0.8m) was placed on the table and attached to the GRP by means of a cable with 940kohm total impedance. The equipment under test, was installed in a representative system as described in section 7 of IEC /EN 61000-4-2, and its cables were placed on the HCP and isolated by an insulating support of 0.5mm thickness. A distance of 1-meter minimum was provided between the EUT and the walls of the laboratory and any other metallic structure.

**FLOOR-STANDING EQUIPMENT:**

The equipment under test was installed in a representative system as described in section 7 of IEC/EN 61000-4-2, and its cables were isolated from the Ground Reference Plane by an insulating support of 0.1-meter thickness. The GRP consisted of a sheet of aluminum that is at least 0.25mm thick, and 2.5meters square connected to the protective grounding system and extended at least 0.5 meters from the EUT on all sides.

**4.1.3. Test Procedure**

The test generator necessary to perform direct and indirect application of discharges to the EUT in the following manner:

1) Contact discharge was applied to conductive surfaces and coupling planes of the EUT.

During the test, it was performed with single discharges. For the single discharge time between successive single discharges was at least 1 second.

**Vertical Coupling Plane (VCP):**

The coupling plane, of dimensions 0.5m x 0.5m, is placed parallel to, and positioned at a distance 0.1m from, the EUT, with the Discharge Electrode touching the coupling plane.

The four faces of the EUT will be performed with electrostatic discharge.

**Horizontal Coupling Plane (HCP):**

The coupling plane is placed under to the EUT. The generator shall be positioned vertically at a distance of 0.1m from the EUT, with the Discharge Electrode touching the coupling plane.

The four faces of the EUT will be performed with electrostatic discharge.

2) Air discharges at insulation surfaces of the EUT.

It was at least ten single discharges with positive and negative at the same selected point.

3) For the actual test configuration, please refer to the related Item –EUT Test Photos.





**4.1.4. Test Data**

Test Mode: Mode 1  
 Power Source: AC 230V, 50Hz  
 Temp.(°C)/Hum.(%RH): Tem.: 23.7°C Hum.: 54%

Item	Contact Discharge to conducted surfaces and to coupling planes		Air Discharge at insulating surfaces
	Direct Contact Discharge	Indirect Contact Discharge	
Test Voltage	Reaction of EUT / Result	Reaction of EUT / Result	Reaction of EUT / Result
+2kV	n.r.r. PASS	n.r.r. PASS	n.r.r. PASS
-2kV	n.r.r. PASS	n.r.r. PASS	n.r.r. PASS
+4kV	n.r.r. PASS	n.r.r. PASS	n.r.r. PASS
-4kV	n.r.r. PASS	n.r.r. PASS	n.r.r. PASS
+6kV	-	-	n.r.r. PASS
-6kV	-	-	n.r.r. PASS
+8kV	-	-	n.r.r. PASS
-8kV	-	-	n.r.r. PASS

Remarks: n.r.r. = no reaction recognized

Performace Criteria B observed and No any function degraded during the tests.

## 4.2. Radiated, RF Electromagnetic Fields Test

### 4.2.1. Test Standard and Specification

Test Standard	ETSI EN 301 489-1 V2.2.3 Clause 9.2
Basic Standard	EN 61000-4-3: 2006+A1:2008+A2:2010
Required Performance	A
Frequency Range	80MHz to 6GHz
Field Strength	3 V/m
Modulation	1kHz Sine Wave, 80%, AM Modulation
Frequency Step	1 % of preceding frequency value
Polarity of Antenna	Horizontal and Vertical
Test Distance	3 m
Antenna Height	1.5 m
Dwell Time	at least 3 seconds

### 4.2.2. Test Setup

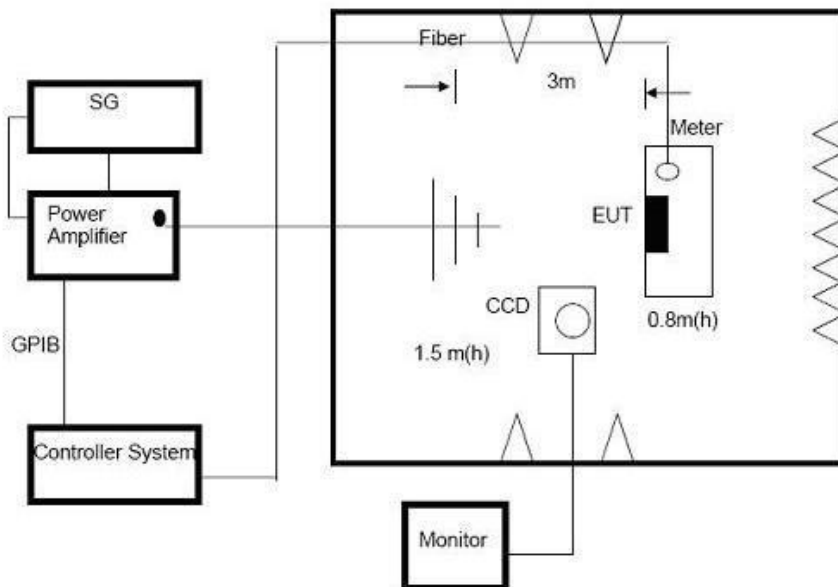

### 4.2.3. Test Procedure

The EUT and support equipment, which are placed on a table that is 0.8 meter above ground and the testing was performed in a fully-anechoic chamber. The testing distance from antenna to the EUT was 3 meters.

- 1) The field strength level was 3V/m



- 2) The frequency range is swept from 80 MHz to 6000 MHz with the signal 80%amplitude modulated with a 1kHz sine wave.
- 3) The dwell time at each frequency shall be not less than the time necessary for the EUT to be able to respond, but shall in no case be less than 0.5s.
- 4) The test was performed with the EUT exposed to both vertically and horizontally polarized fields on each of the four sides.

#### 4.2.4. Test Data

Test Mode: Mode 1  
 Power Source: AC 230V, 50Hz  
 Temp.(°C)/Hum.(%RH): Tem.: 23.7°C Hum.: 54%

Frequency Range (MHz)	RF Field Position	R.F. Field Strength	Azimuth	Observation	Perform. Criteria	Results
80~6000	H / V	3 V/m (rms) AM Modulated 1000Hz, 80%	Front	CT,CR	A	PASS
			Rear			
			Left			
			Right			

Test Mode: Mode 1  
 Power Source: AC 230V, 50Hz  
 Temp.(°C)/Hum.(%RH): Tem.: 21.6°C Hum.: 50%

EUT operating Mode		Polarity	Position (°)	Throughput(95%)
Data Mode (LTE Band1)	Uplink	H	Front	≧ 95
		V	Front	≧ 95
	Downlink	H	Front	≧ 95
		V	Front	≧ 95

Note: All supported band has been tested, only worst data listed.

## 4.3. Fast Transients, Common Mode Test

### 4.3.1. Test Standard and Specification

Test Standard	ETSI EN 301 489-1 V2.2.3 Clause 9.4
Basic Standard	EN 61000-4-4:2012
Required Performance	B
Test Voltage:	Power Line: 1 kV Signal/Control Line: 0.5 kV
Polarity:	Positive & Negative
Impulse Frequency:	5 kHz
Impulse Wave shape :	Tr/Th 5/50 ns
Burst Duration:	15 ms for 5KHz Repetition Frequency 0.75 ms for 100KHz Repetition Frequency
Burst Period:	300 ms
Test Duration	1 min

### 4.3.2. Test Setup

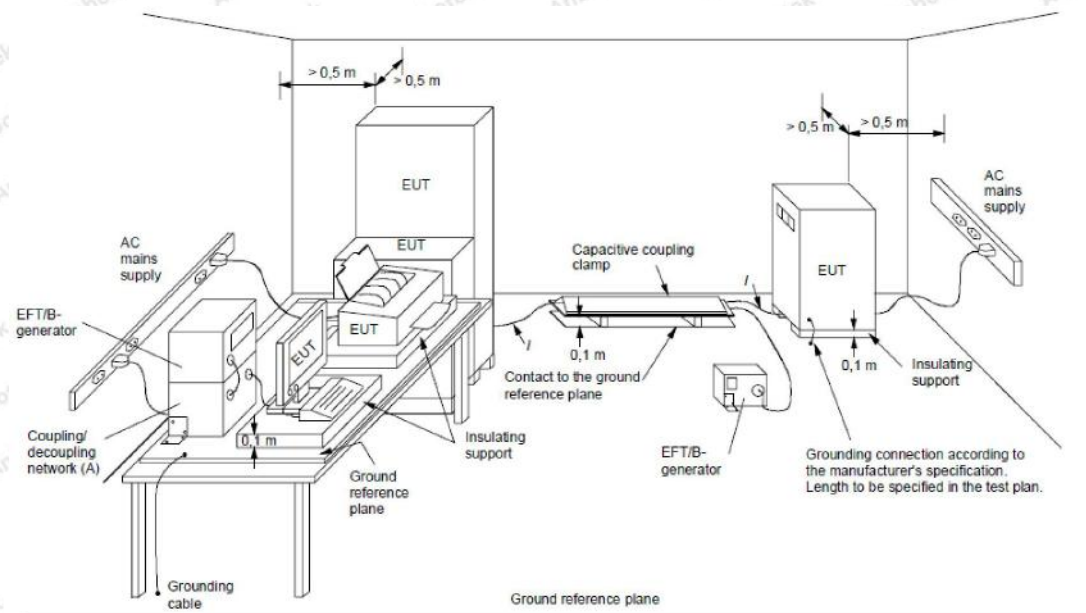

Note: (A) location for supply line coupling

(B) location for signal lines coupling

For the actual test configuration, please refer to the related item – Photographs of the Test Setup

### 4.3.3. Test Procedure

The EUT and support equipment, are placed on a table that is 0.8 meter above a metal ground plane measured 1m\*1m min. and 0.65mm thick min.

The other condition as following manner:



- 1) The distance between any coupling devices and the EUT should be (0.5-0/+0.1)m for table-top equipment testing, and (1.0±0.1)m for floor standing equipment.
- 2) Both positive and negative polarity discharges were applied.
- 3) The duration time of each test sequential was 1 minute
- 4) For the actual test configuration, please refer to the related Item –EUT Test Photos.

#### 4.3.4. Test Data

Test Mode: Mode 1  
 Power Source: AC 230V, 50Hz  
 Temp.(°C)/Hum.(%RH): Tem.: 23.7°C Hum.: 54%

Coupling Line		Test level (kV)								Observation	Criterion	Results
		0.5		1		2		4				
		+	-	+	-	+	-	+	-			
AC Line	L	P	P	P	P					TT,TR	B	PASS
	N	P	P	P	P							PASS
	L+N	P	P	P	P							PASS

Note: 1) There was not any unintentional transmission in standby mode  
 2) In the table: 'P' represents 'PASS'; 'F' represents 'FAIL'.

## 4.4. Surges Test

### 4.4.1. Test Standard and Specification

Test Standard	ETSI EN 301 489-1 V2.2.3 Clause 9.8
Basic Standard	EN 61000-4-5: 2014+A1:2017
Required Performance	B
Wave-Shape:	Combination Wave 1.2/50 us Open Circuit Voltage 8 /20 us Short Circuit Current
Test Voltage:	Line to Line: 1 kV; Line to ground: 2kV
Generator Source:	2 ohm between networks
Impedance:	12 ohm between network and ground
Polarity:	Positive/Negative
Phase Angle:	0°/90°/180°/270°
Pulse Repetition Rate:	1 time / min. (maximum)
Number of Tests:	5 positive and 5 negative at selected points

### 4.4.2. Test Setup

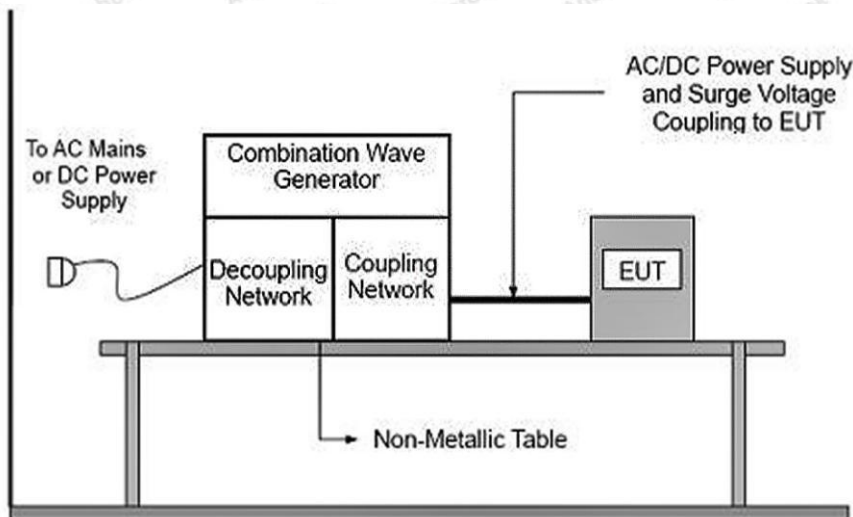

### 4.4.3. Test Procedure

#### 1) For EUT power supply:

The surge is to be applied to the EUT power supply terminals via the capacitive coupling network. Decoupling networks are required in order to avoid possible adverse effects on equipment not under test that may be powered by the same lines, and to provide sufficient decoupling impedance to the surge wave. The power cord between the EUT and the coupling/decoupling networks shall be 2meters in length (or shorter).



For double-insulated products without PE or external earth connections, the test shall be done in a similar way as for grounded products but without adding any additional external grounded connections. If there are no other possible connections to earth, line-to-ground tests may be omitted.

2) For Unshielded unsymmetrical interconnection lines:

The surge is applied to the lines via the capacitive coupling. The coupling /decoupling networks shall not influence the specified functional conditions of the EUT. The interconnection line between the EUT and the coupling/decoupling networks shall be 2 meters in length.

3) Unshielded symmetrical interconnections communication lines:

The surge is applied to the lines via gas arrestors coupling. Test levels below the ignition point of the coupling arrester cannot be specified. The interconnection line between the EUT and the coupling/decoupling networks shall be 2 meters in length.

4) For Shielded lines:

Direct application,

The EUT is isolated from ground and the surge is applied to its metallic enclosure; the termination (or auxiliary equipment) at the port(s) under test is grounded. This test applies to equipment with single or multiple shielded cables.

Rules for application of the surge to shielded lines:

i) Shields grounded at both ends

> The surge injection on the shield.

ii) Shields grounded at one end

> If in the installation the shield is connected only at the auxiliary equipment, test shall be done in that configuration but with the generator still connected to the EUT side. If cable lengths allow, the cables shall be on insulated supports 0.1 m above the ground plane or cable tray.

For products which do not have metallic enclosures, the surge is applied directly to the shielded cable.

- Alternative coupling method for testing single cables in a multi-shield configuration, Surges are applied in close proximity to the interconnection cable under test by a wire. The length of the cable between the port(s) under test and the device attached to the other end of the cable shall be the lesser of the maximum length permitted by the EUT's specification, or 20 m. Where the length exceeds 1 m, excess lengths of cables shall be bundled at the approximate centre of the cables with the bundles 30 cm to 40 cm in length.

#### 4.4.4. Test Data

Test Mode: Mode 1  
 Power Source: AC 230V, 50Hz  
 Temp.(°C)/Hum.(%RH): Tem.: 23.7°C Hum.: 54%

Coupling Line		Test level								Observation	Criterion	Result	
		0.5 kV		1 kV		2 kV		4 kV					
		+	-	+	-	+	-	+	-				
AC line	L-N	0°	P	P	P	P					TT,TR	B	PASS
		90°	P	P	P	P							
		180°	P	P	P	P							
		270°	P	P	P	P							

Note: 1)There was not any unintentional transmission in standby mode  
 2) In the table: 'P' represents 'PASS'; 'F' represents 'FAIL'.



## 4.5. Radio Frequency, Common Mode Test

### 4.5.1. Test Standard and Specification

Test Standard	ETSI EN 301 489-1 V2.2.3 Clause 9.5
Basic Standard	EN 61000-4-6:2014
Required Performance	A
Frequency Range:	0.15 MHz - 80 MHz/0.15MHz~10MHz, 10MHz~30MHz, 30MHz~80MHz
Field Strength:	3 Vr.m.s./3V~1Vr.m.s./3Vr.m.s.
Modulation:	1kHz Sine Wave, 80%, AM Modulation
Frequency Step:	1 % of fundamental
Dwell Time:	at least 3 seconds

### 4.5.2. Test Setup

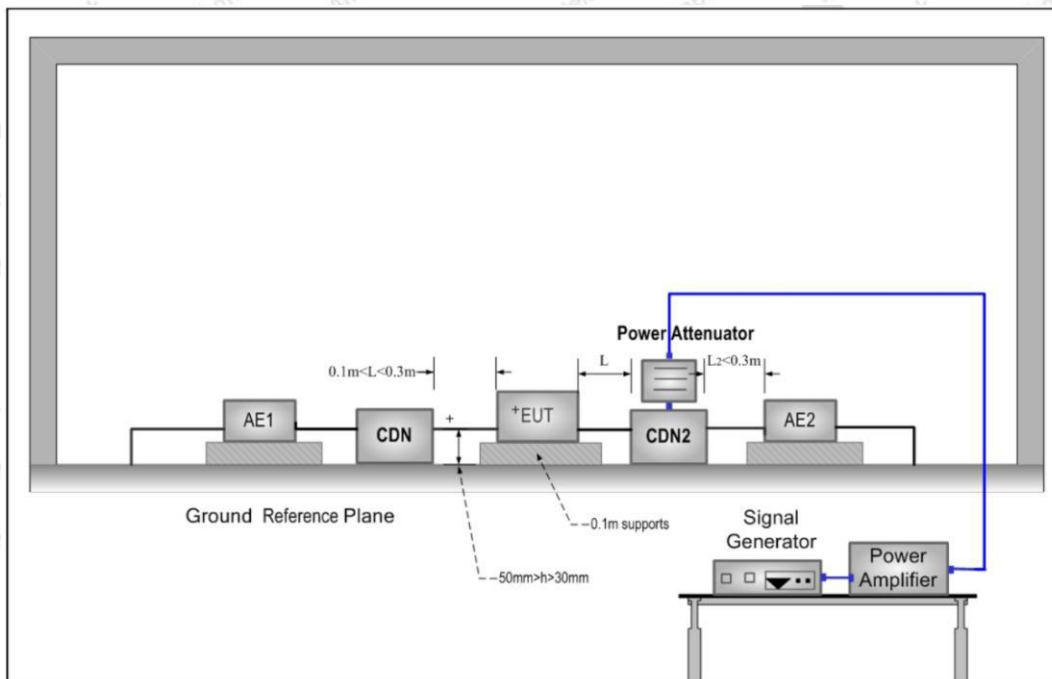

### 4.5.3. Test Procedure

- 1) The EUT was placed on an insulating support of 0.1m height above a ground reference Plane, arranged and connected to satisfy its functional requirement. All cables exiting the EUT was supported at a height of at least 30 mm above the ground reference plane.
- 2) The coupling and decoupling devices were required, they were located between 0.1 m and 0.3 m from the EUT. This distance was to be measured horizontally from the projection of the EUT on to the ground reference plane to the coupling and decoupling device.

3) Each AE, used with clamp injection, shall be placed on an insulating support 0.1 m above the ground reference plane. A decoupling network shall be installed on each cable between the EUT and AE except the cable under test. All cables connected to each AE, other than those being connected to the EUT, shall be provided with decoupling networks. The decoupling networks connected to each AE (except those on cables between the EUT and AE) shall be applied no further than 0.3 m from the AE. The cable(s) between the AE and the decoupling network (s) or in between the AE and the injection clamp shall not be bundled nor wrapped and shall be kept between 30 mm and 50 mm above the ground reference plane.

4) The frequency range was swept from 150 kHz to 230 MHz, using the signal levels established during the setting process, and with the disturbance signal 80% amplitude modulated with a 1 kHz sine wave, pausing to adjust the RF signal level or to change coupling devices as necessary. Where the frequency was swept incrementally, the step size do not exceed 1% of the preceding frequency

#### 4.5.4. Test Data

Test Mode: Mode 1  
 Power Source: AC 230V, 50Hz  
 Temp.(°C)/Hum.(%RH): Tem.: 23.7°C Hum.: 54%

Voltage (V)	Test Frequency (MHz)	Tested Line	Injection Method.	Performance Criterion	Test Result
3	0.15 – 80	AC line	CDN-M2	CT/CR	PASS

Remark: For normal operating function: There was no change compared with the initial operation during and after the test.

Test Mode: Mode 1  
 Power Source: AC 230V, 50Hz  
 Temp.(°C)/Hum.(%RH): Tem.: 23.7°C Hum.: 54%

Voltage (V)	Test Frequency (MHz)	Tested Line	Injection Method.	Performance Criterion	Test Result
3	0.15 – 10	AC line	CDN-M2	CT/CR	PASS
3~1	10~30	AC line	CDN-M2	CT/CR	PASS
3	30~80	AC line	CDN-M2	CT/CR	PASS

Remark: For normal operating function: There was no change compared with the initial operation during and after the test.



Report No.: 18220WC20051501E

Page 46 of 76

Test Mode: Mode 1  
Power Source: AC 230V, 50Hz  
Temp.(°C)/Hum.(%RH): Tem.: 22.1°C Hum.: 47%

EUT operating Mode		Position(MHz)	Throughput(95%)
Data Mode (LTE Band1)	Uplink	13.5	≧ 95
	Downlink	14.7	≧ 95

Note: All supported band has been tested, only worst data listed.

## 4.6. Voltage Dips and Interruptions

### 4.6.1. Test Standard and Specification

Test Standard	ETSI EN 301 489-1 V2.2.3 Clause 9.7
Basic Standard	EN 61000-4-11: 2014+A1:2017
Voltage Dips:	0% reduction, 0.5 Cycle 0% reduction, 1.0 Cycle 70% reduction, 25 Cycles
Voltage Interruptions:	0% reduction, 250 Cycles
Interval between Event:	Minimum 10 seconds
Phase Angle:	0°/180°
Test Cycle:	3 times

### 4.6.2. Test Setup

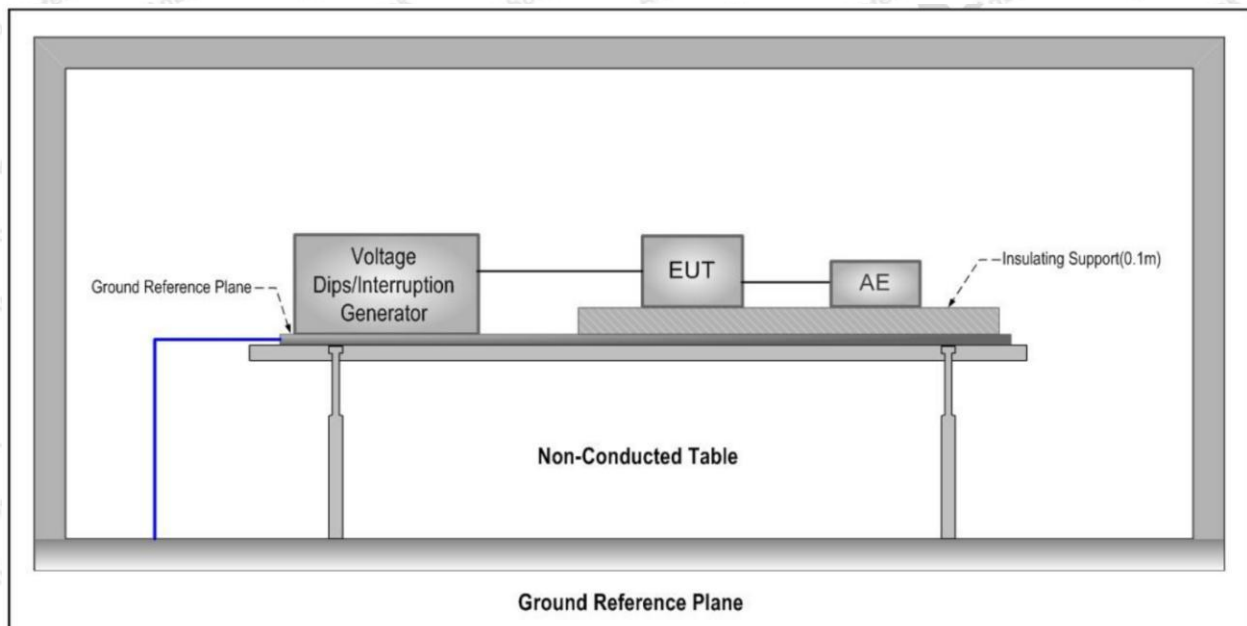

### 4.6.3. Test Procedure

- 1) The EUT was placed on a ground reference plane (GRP) insulated by an insulating support 0.1 m thick and the GRP was placed on a 0.8m high wooden table for table-top equipment. For floor standing equipment, the EUT was placed on a 0.1m high wooden support above the GRP.
2. The test was performed with the EUT connected to the test generator with the shortest power supply cable as specified by the EUT manufacturer.
3. The EUT was tested for each selected combination of test level and duration with a sequence of three dips/interruptions with intervals of 10 s minimum. Each representative mode of operation was tested.
4. For EUT with more than one power cord, each power cord was tested individually.



### 4.6.4. Test Data

Test Mode: Mode 1  
 Power Source: AC 230V, 50Hz  
 Temp.(°C)/Hum.(%RH): Tem.: 23.7°C Hum.: 54%

Ut:230Vac 50Hz	Durations		Event interval (sec)	Total events (time)	Performance Criterion	Result
Voltage residual (%)	(period)	(ms)	10	3	TT/TR	PASS
0	1	20	10	3	TT/TR	PASS
0	0.5	10	10	3	TT/TR	PASS
70	25	500	10	3	TT/TR	PASS
0	250	5000	10	3	TT/TR	PASS
70	0.5	10	10	3	TT or CR	PASS

Ut:100Vac 50Hz	Durations		Event interval (sec)	Total events (time)	Performance Criterion	Result
Voltage residual (%)	(period)	(ms)	10	3	TT/TR	PASS
0	1	20	10	3	TT/TR	PASS
0	0.5	10	10	3	TT/TR	PASS
70	25	500	10	3	TT/TR	PASS
0	250	5000	10	3	TT/TR	PASS
70	0.5	10	10	3	TT or CR	PASS

Ut:240Vac 50Hz	Durations		Event interval (sec)	Total events (time)	Performance Criterion	Result
Voltage residual (%)	(period)	(ms)	10	3	TT/TR	PASS
0	1	20	10	3	TT/TR	PASS
0	0.5	10	10	3	TT/TR	PASS
70	25	500	10	3	TT/TR	PASS
0	250	5000	10	3	TT/TR	PASS
70	0.5	10	10	3	TT or CR	PASS

## APPENDIX I -- TEST SETUP PHOTOGRAPH

Photo of Conducted Emission Test

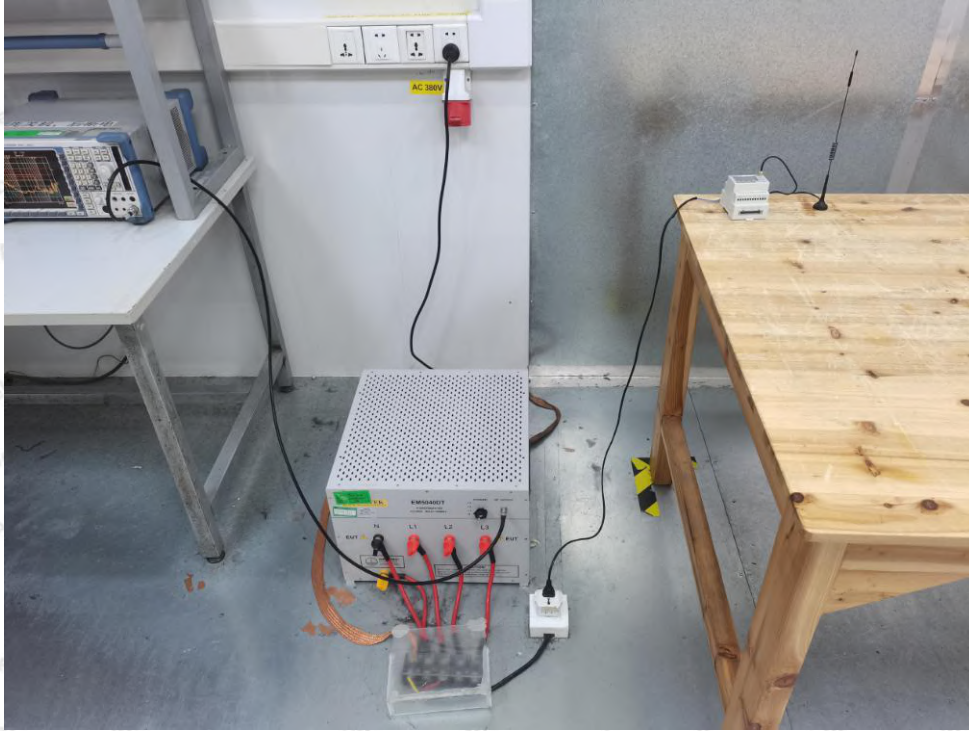

Photo of Radiation Emission Test





Photo of Flicker Test



Photo of Electrostatic Discharge Test

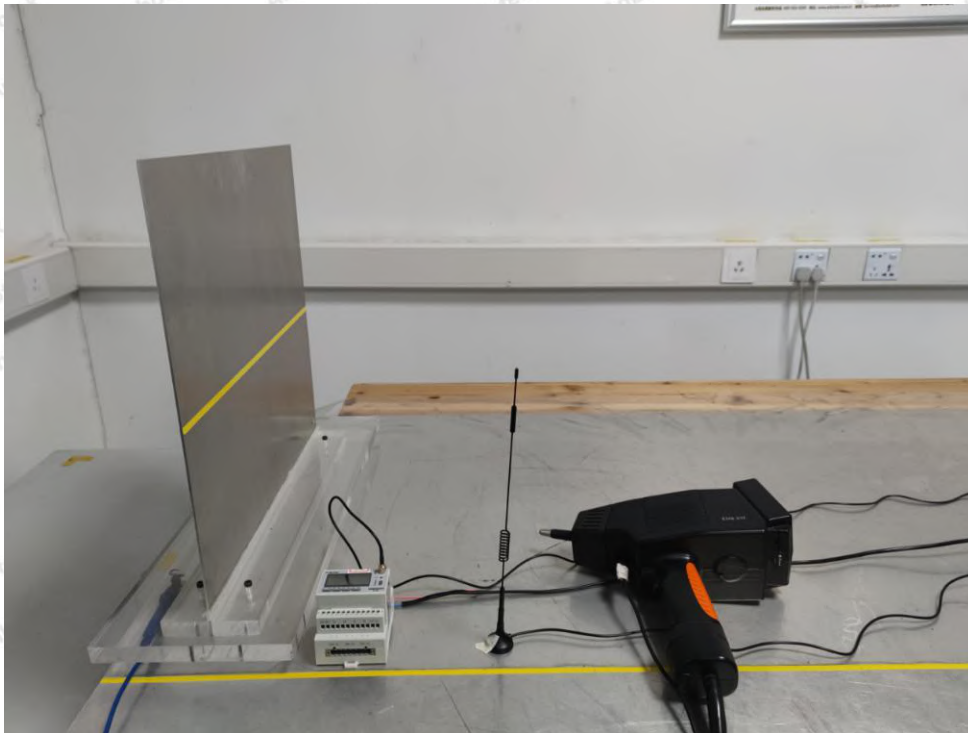



Photo of RF Field Strength Susceptibility Test



Photo of Electrical Fast Transient /Burst Immunity Test

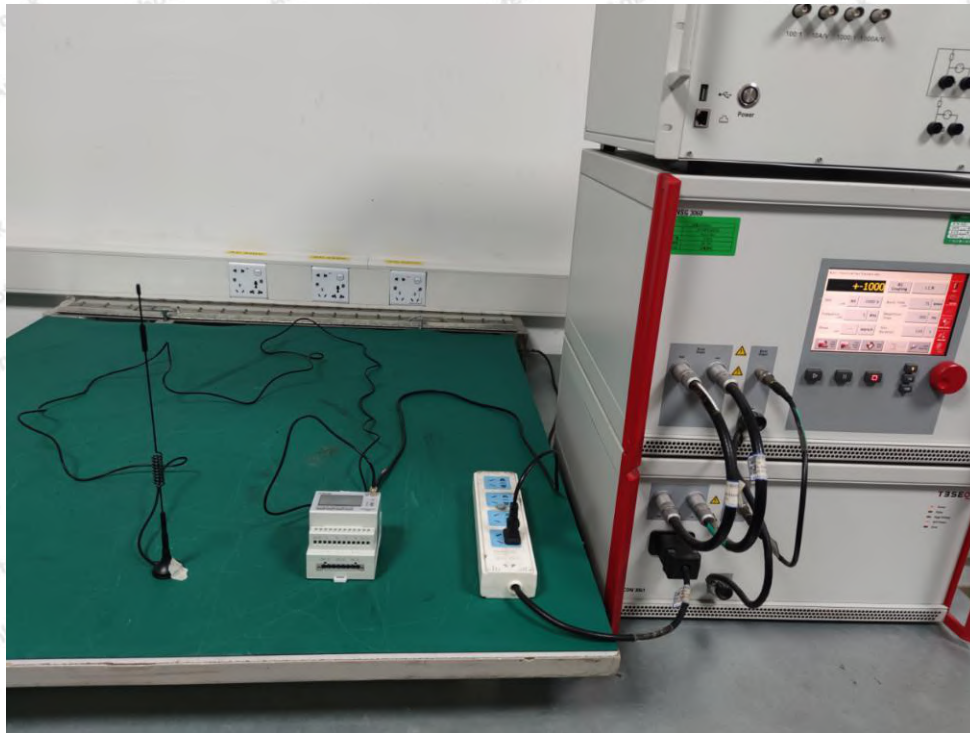

Photo of Surge Test



Photo of Dips Immunity Test

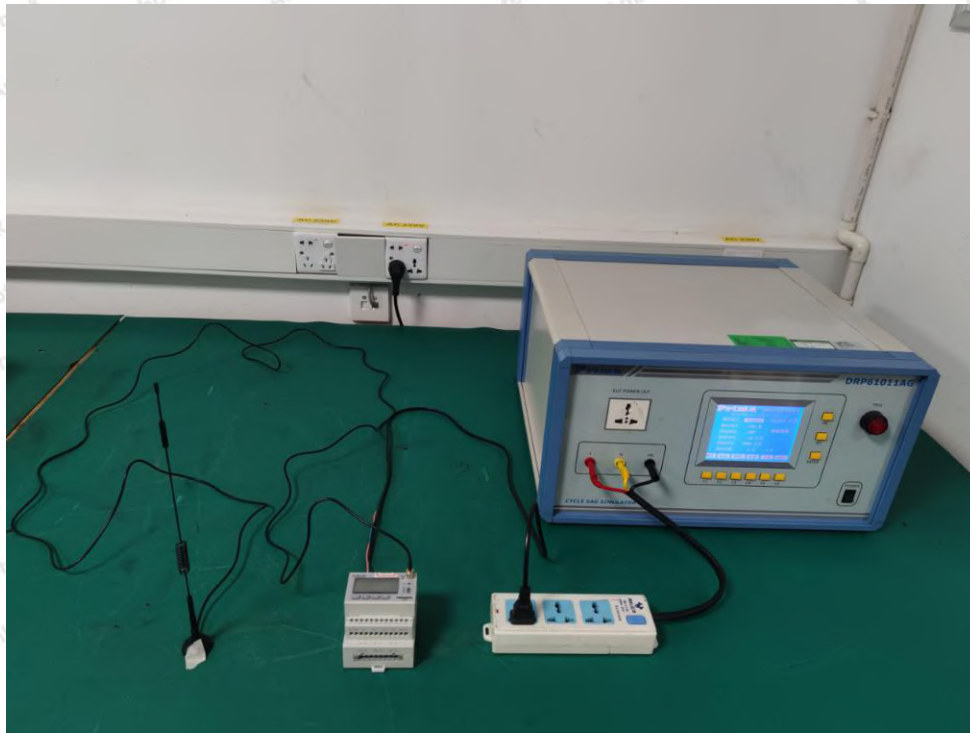
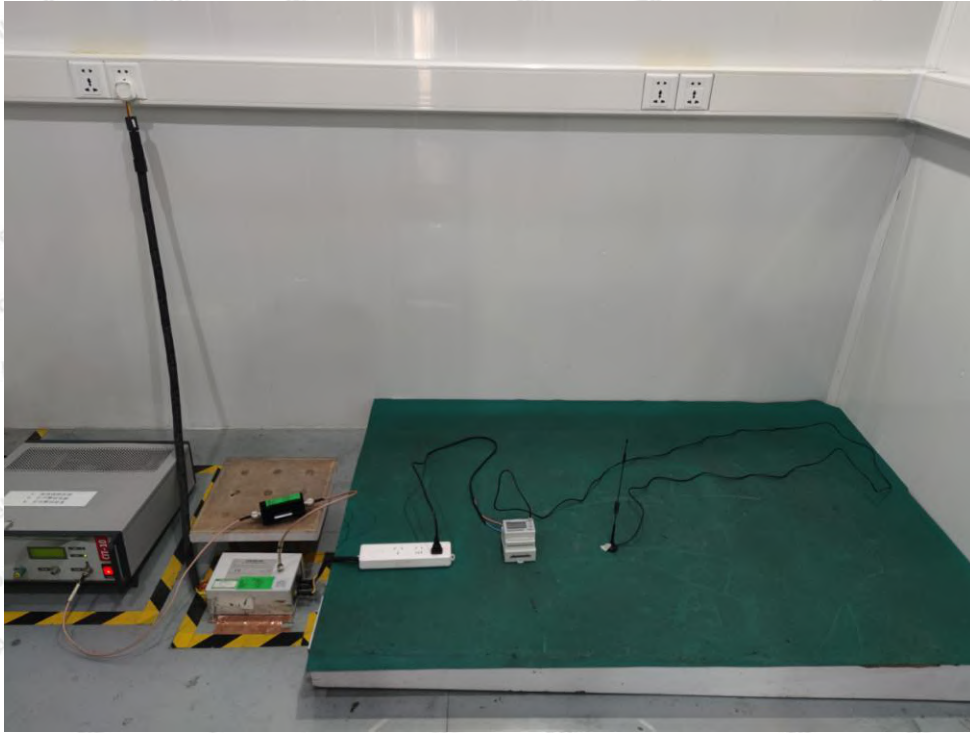

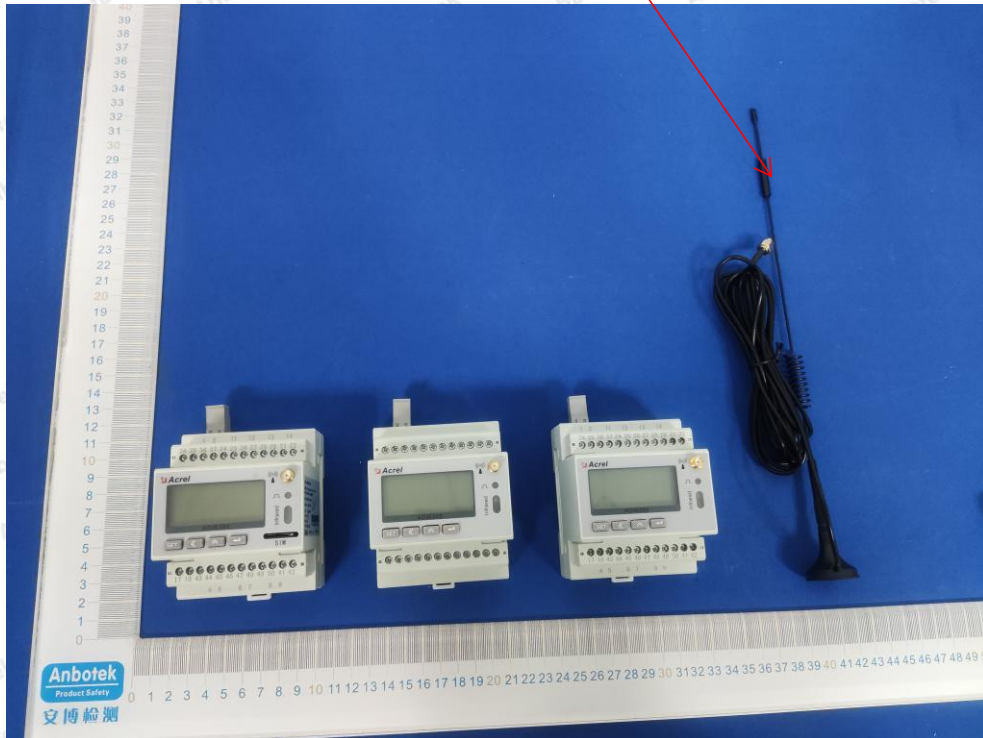

Photo of C/S Test



## APPENDIX II -- EXTERNAL PHOTOGRAPH

SRD/WIFI/LTE ANT





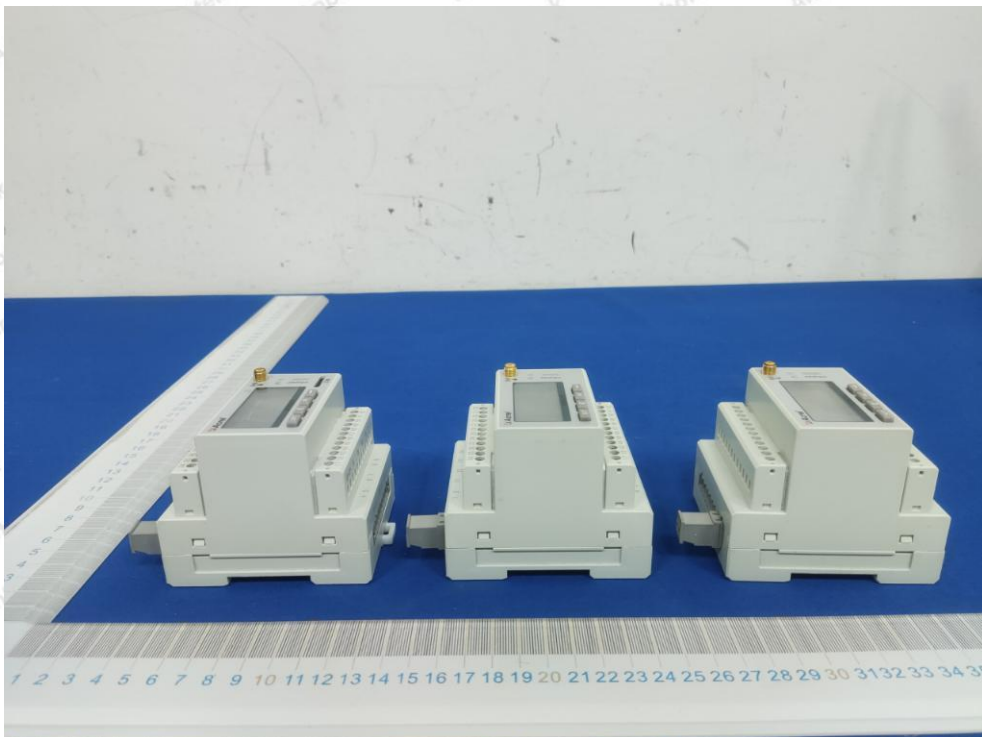

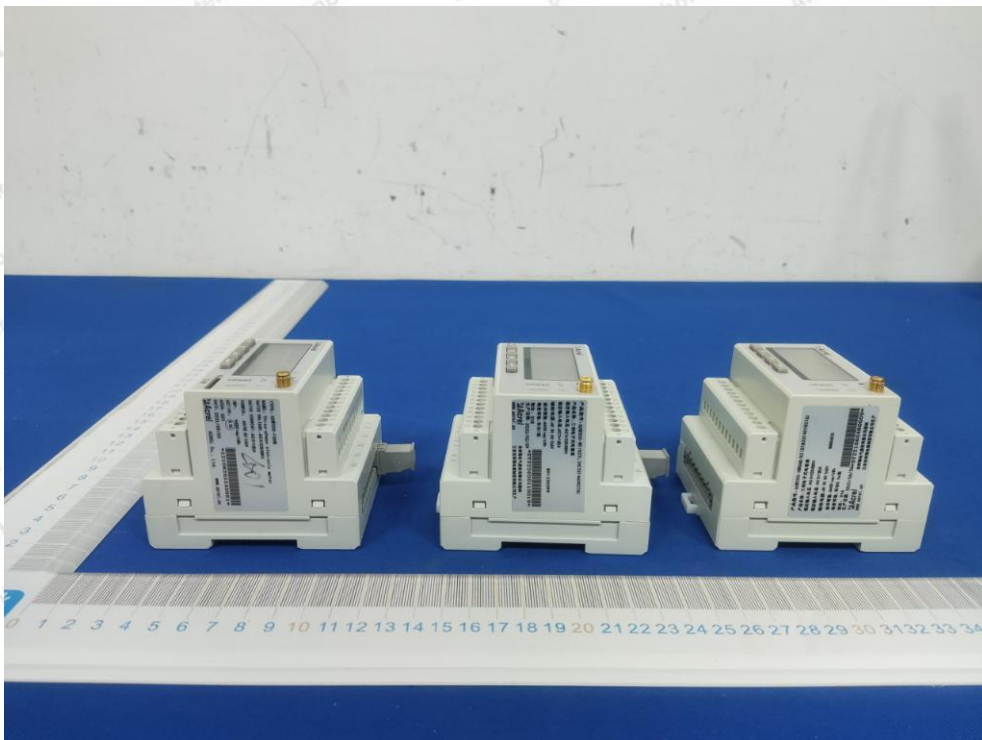





### APPENDIX III -- INTERNAL PHOTOGRAPH

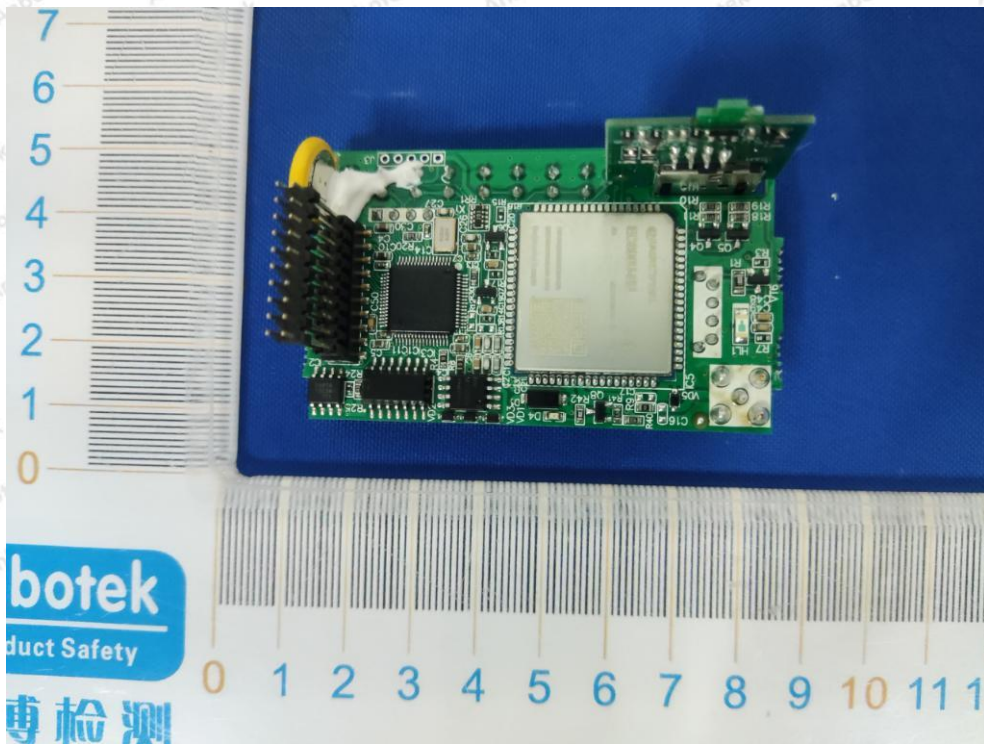
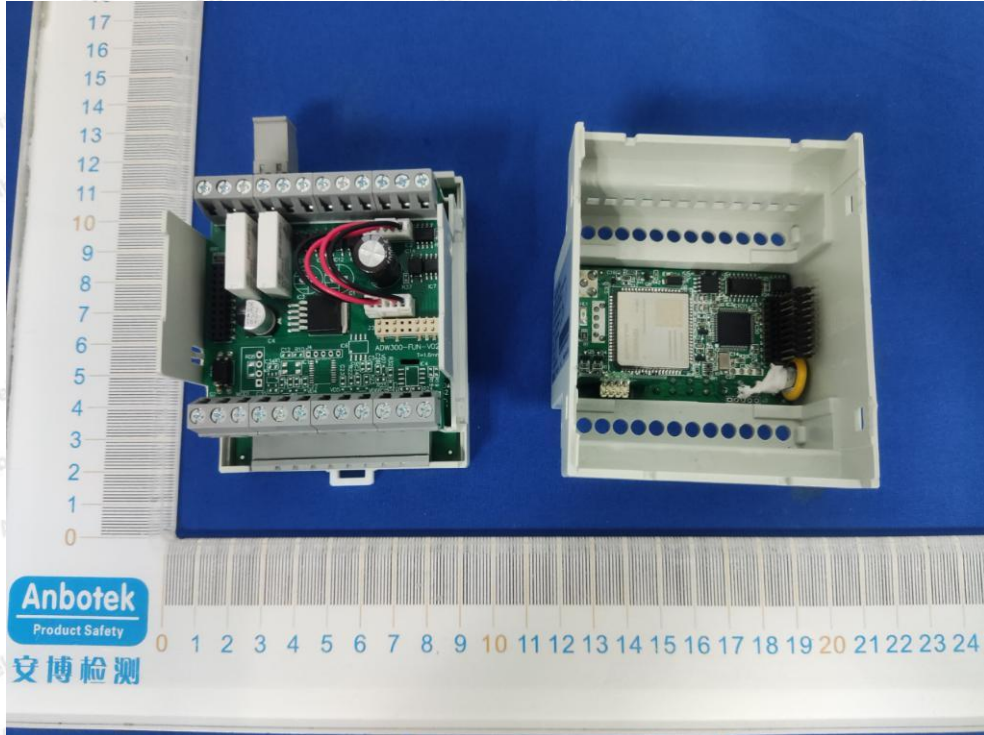



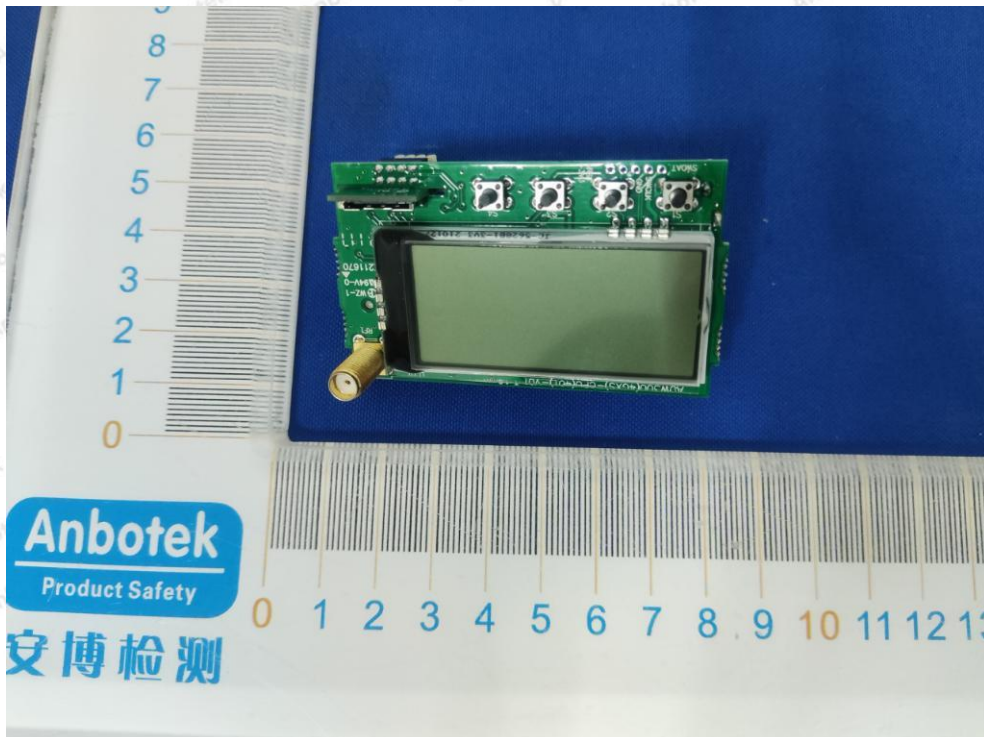
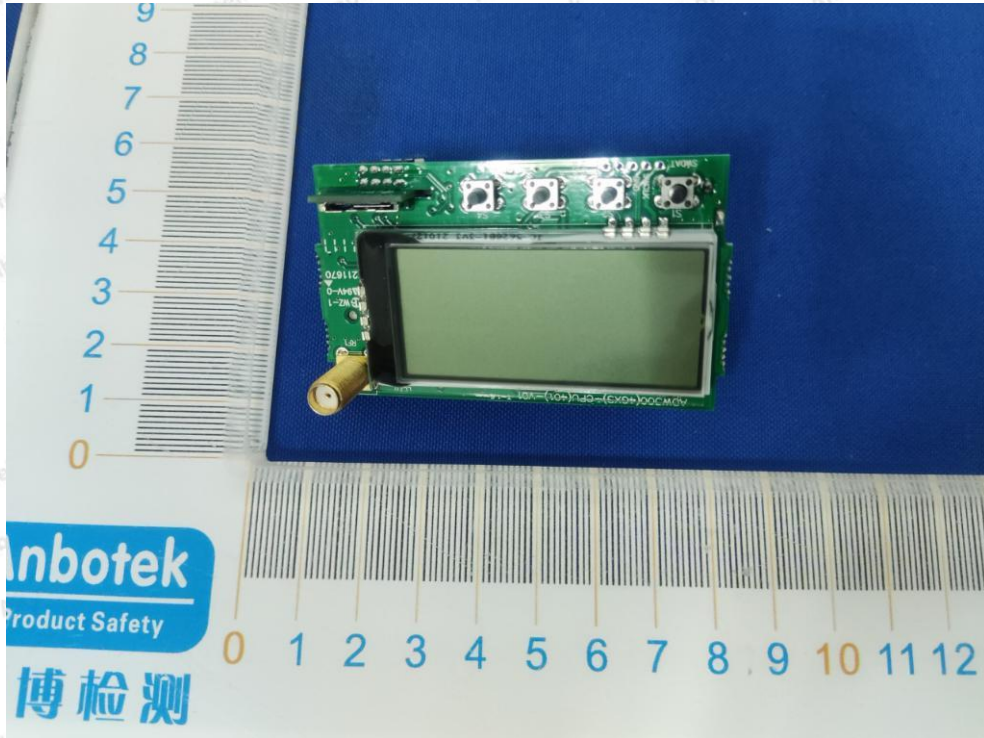











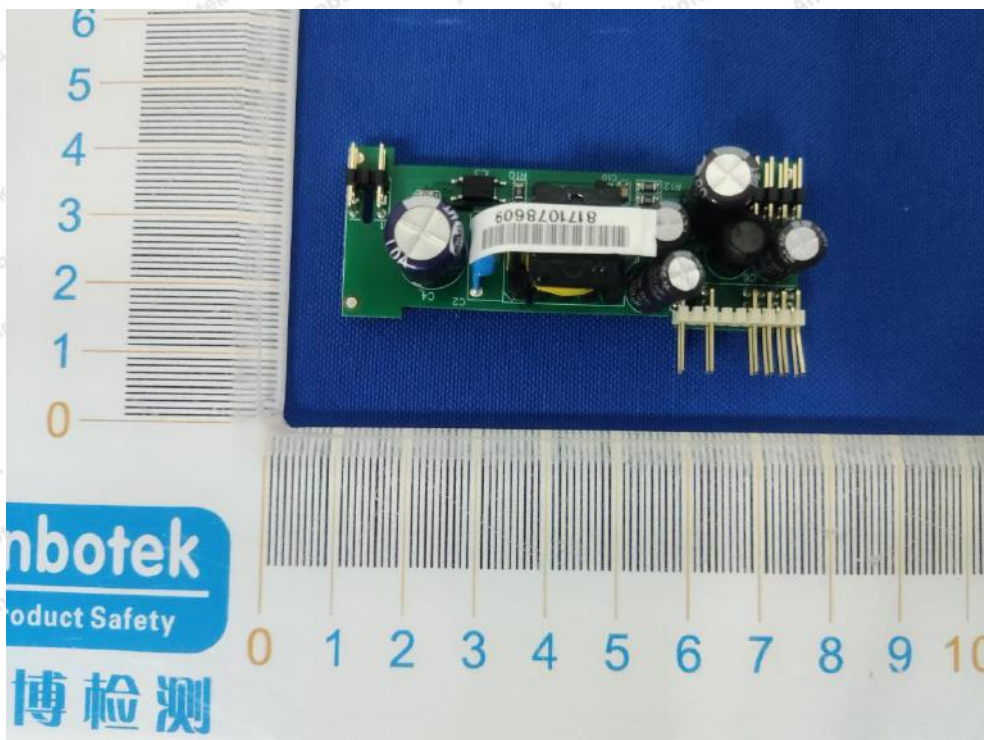







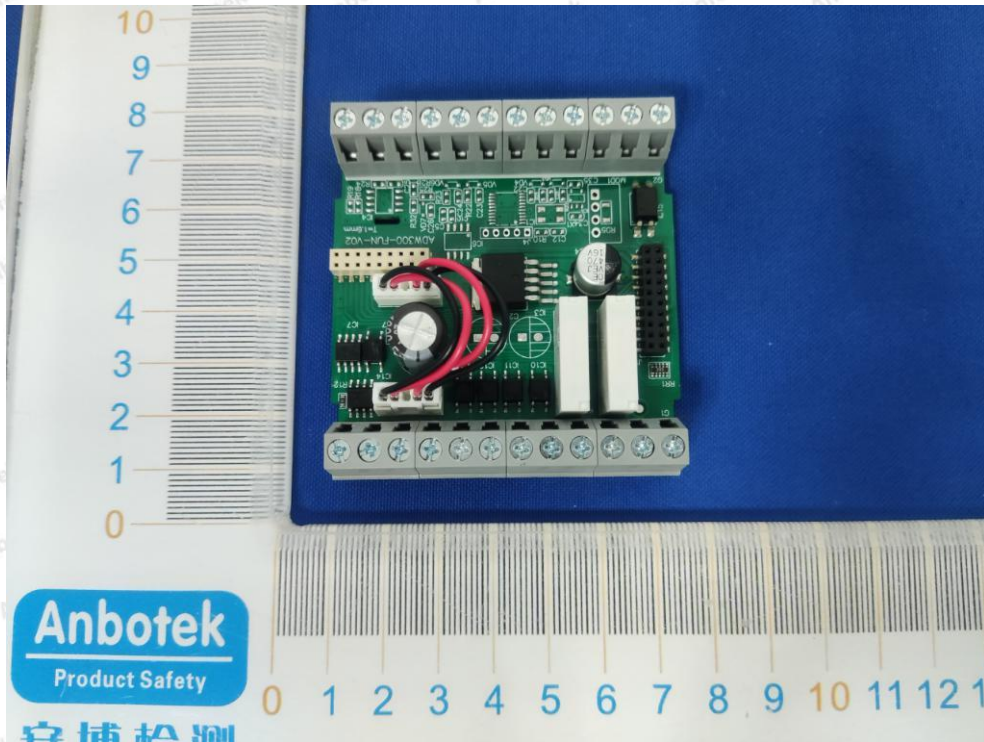



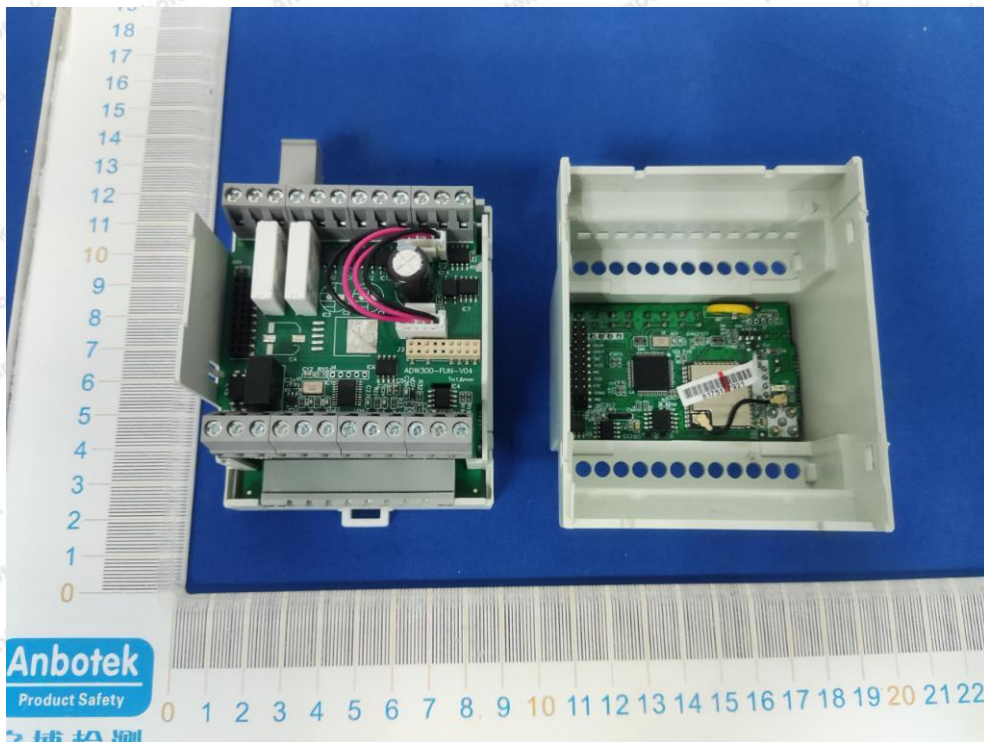
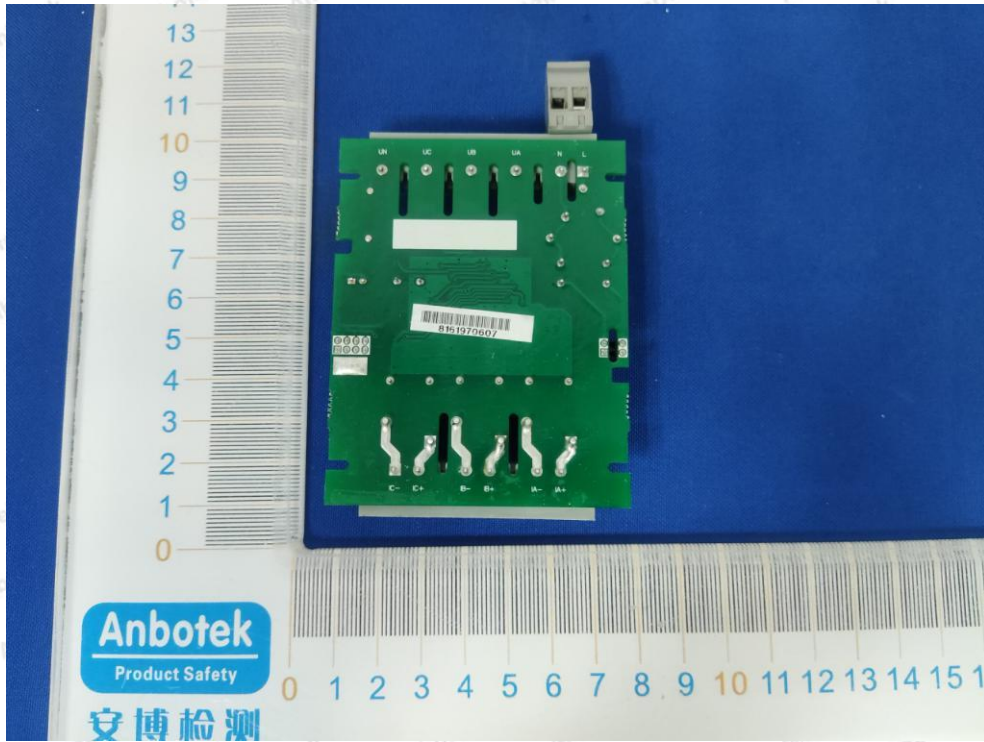

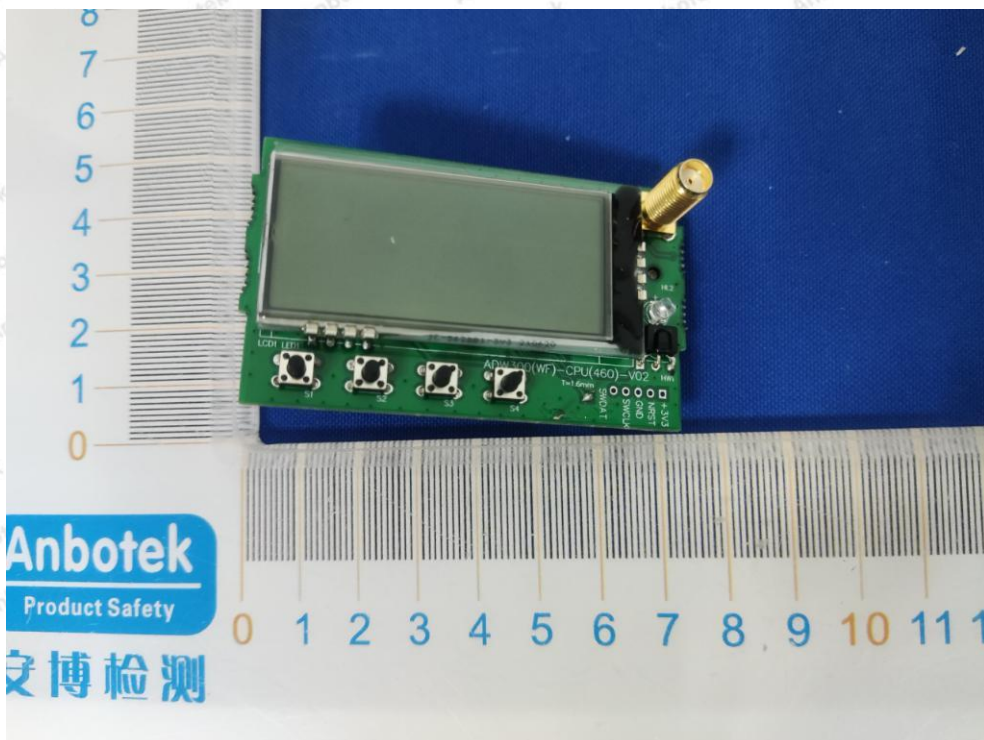



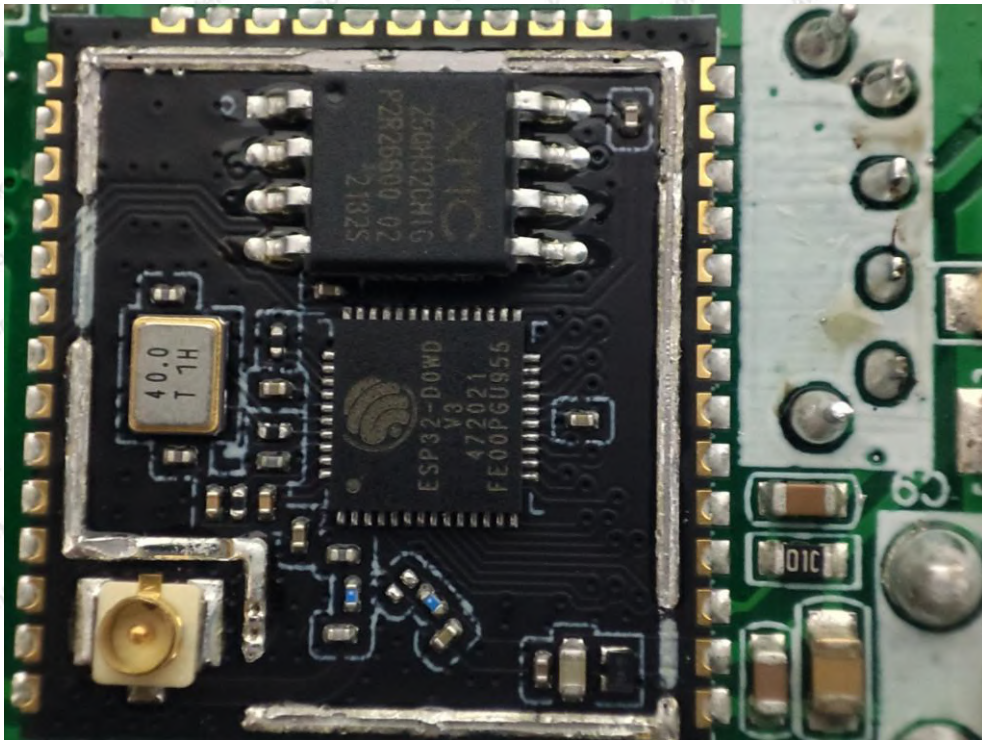







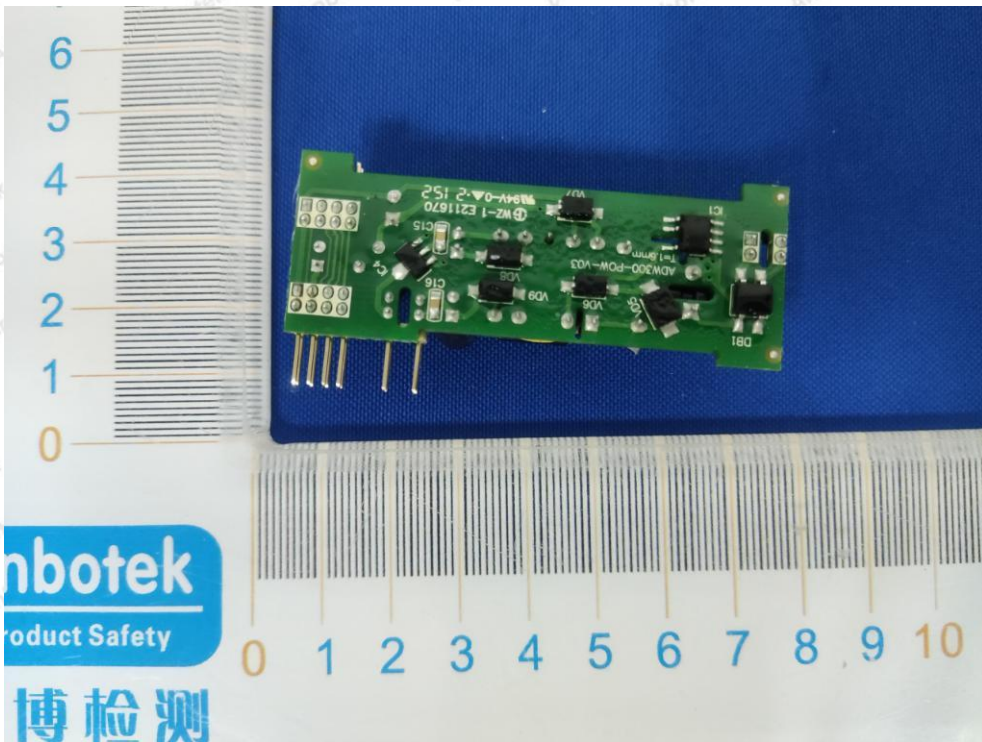
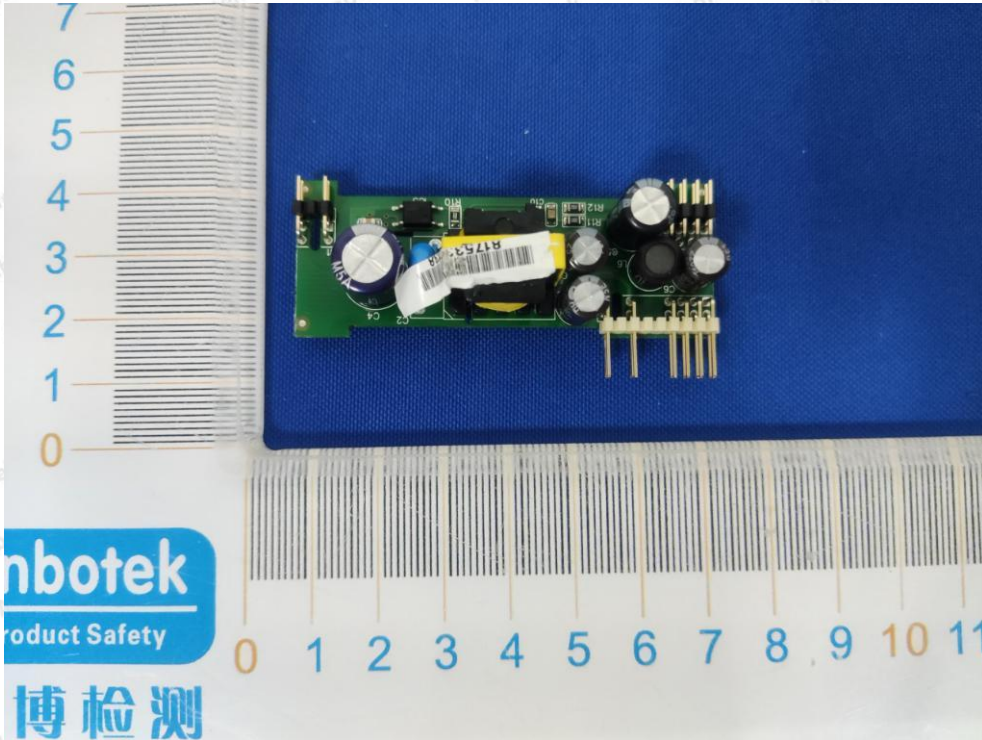



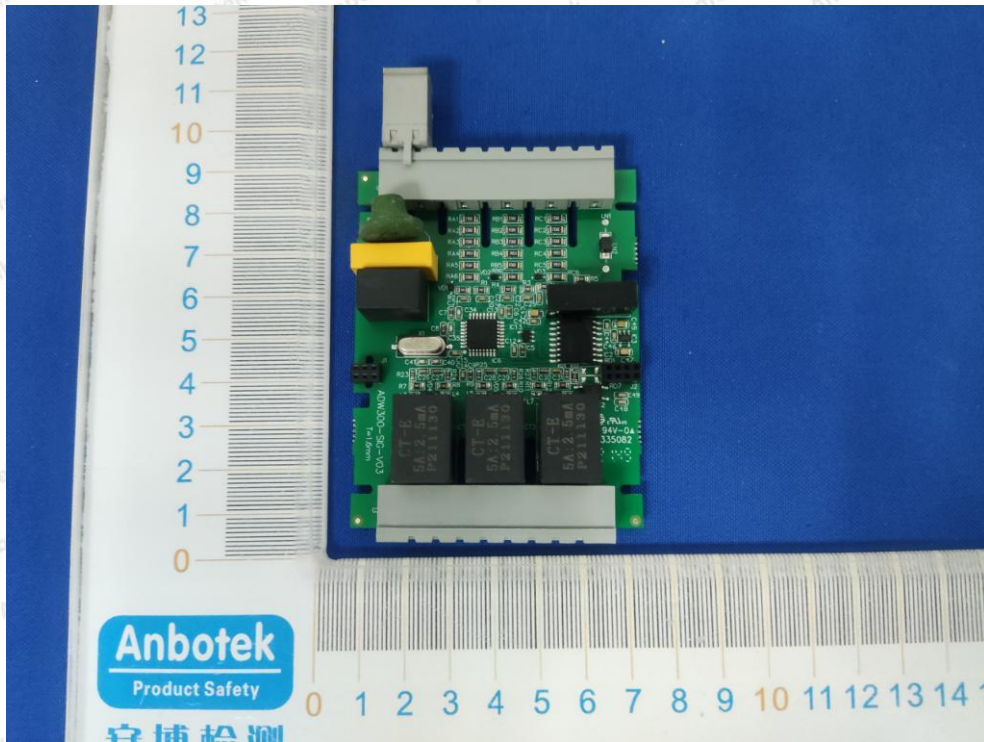



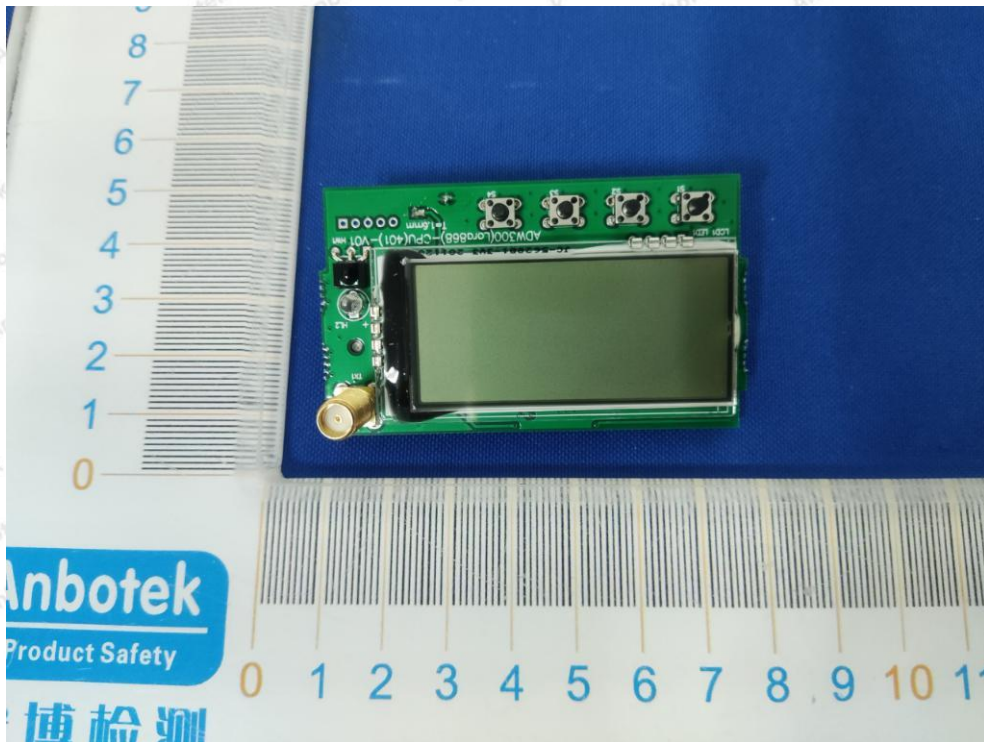
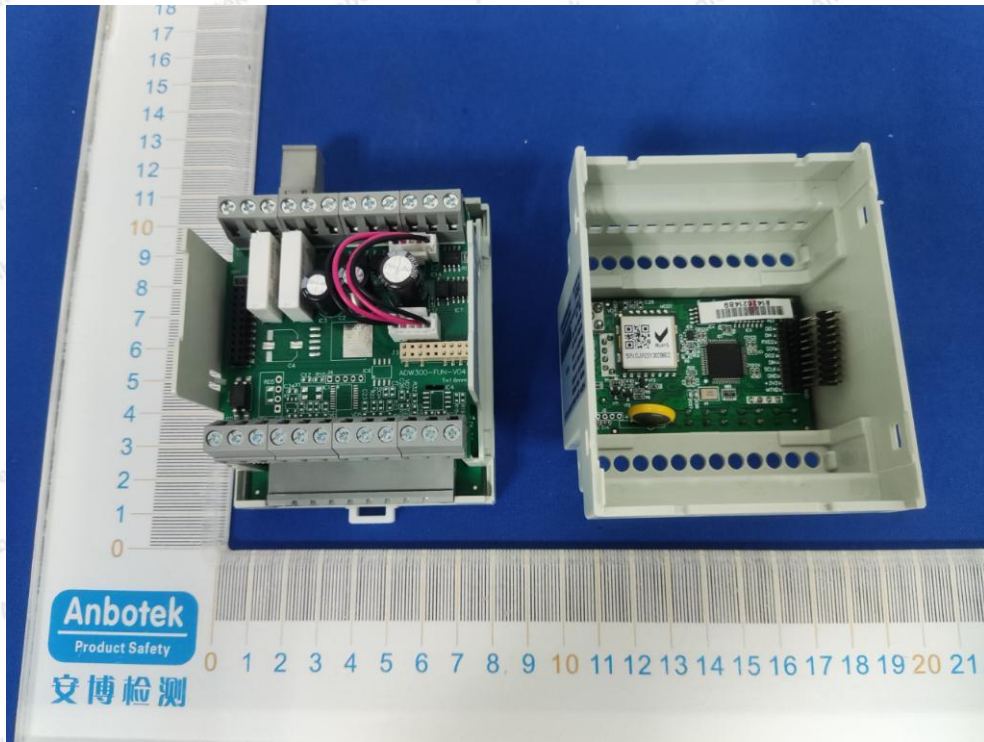







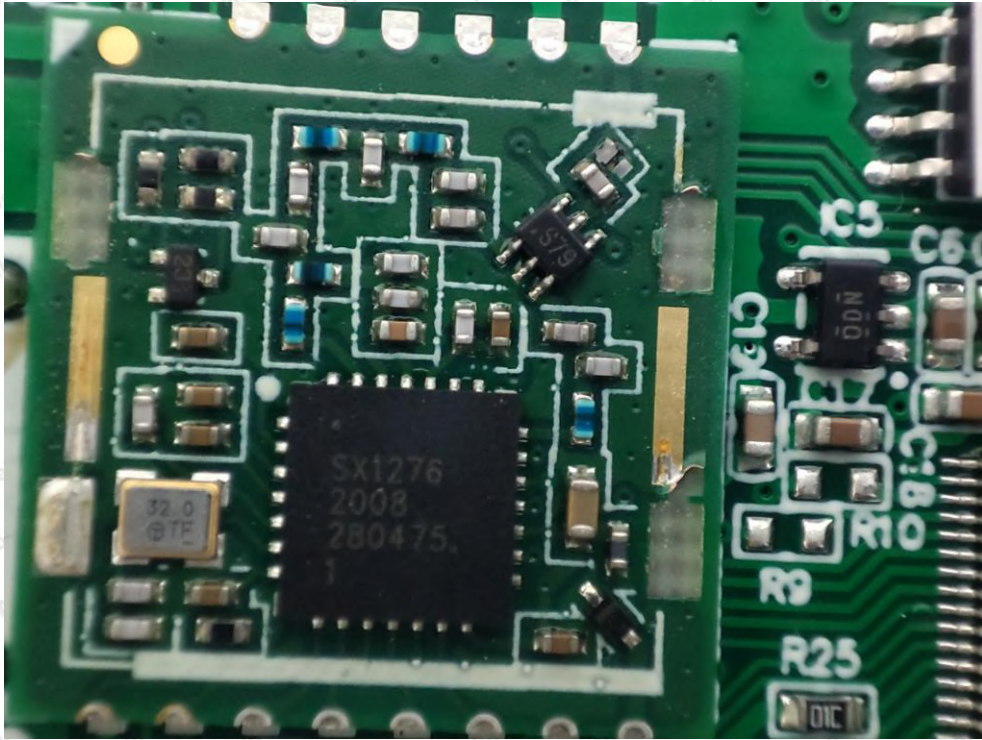



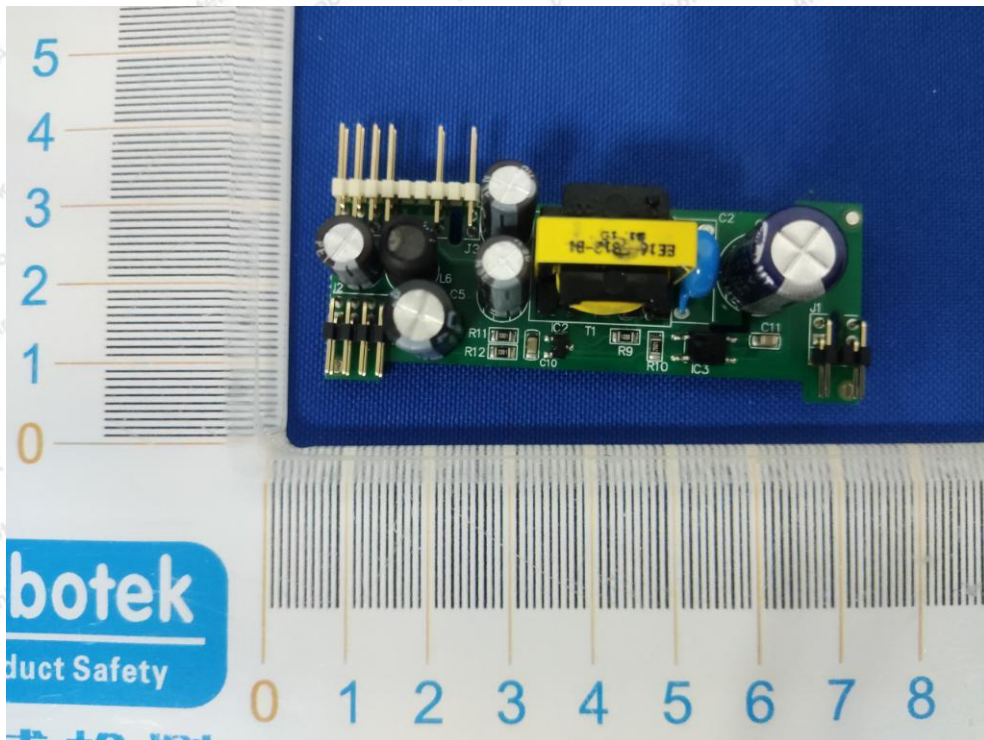



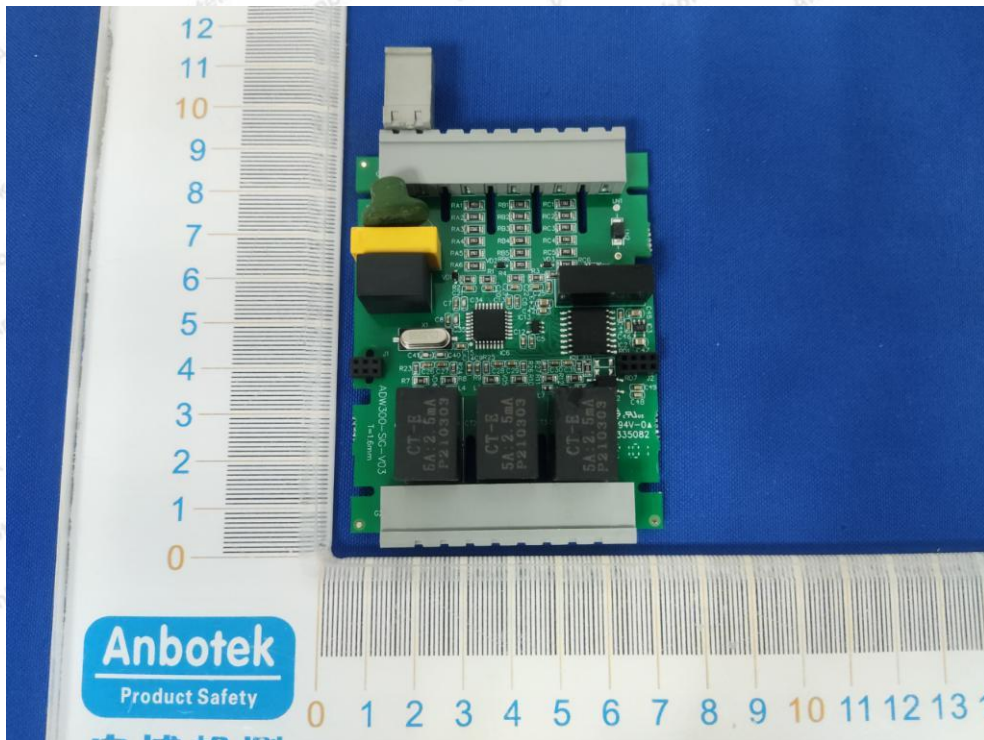
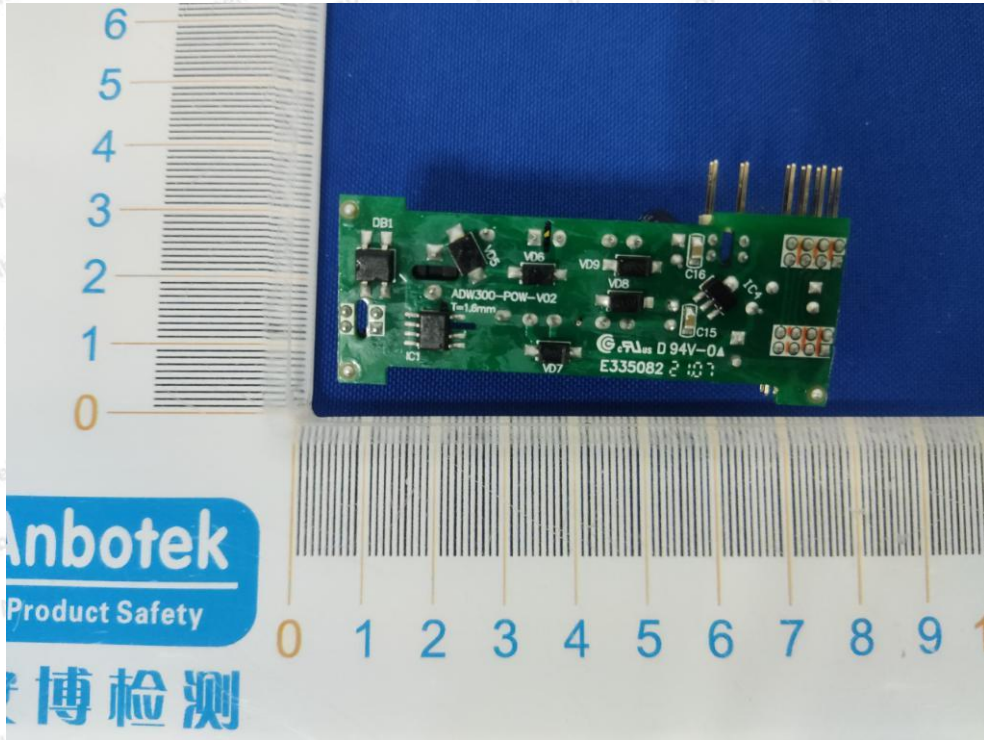



----- End of Report -----