

EMC Test Report

Client Name : **Acrel Co., Ltd.**

Client Address : **No.253, Yulv Road, Jiading, Shanghai, China**

Product Name : **Power Meter**

Report Date : **Mar. 15, 2023**

Shenzhen Anbotek Compliance Laboratory Limited



Contents

1. General Information.....	5
1.1. Client Information.....	5
1.2. Description of Device (EUT).....	5
1.3. Auxiliary Equipment Used During Test.....	5
1.4. Description of Test Mode.....	6
1.5. Test Summary.....	6
1.6. Test Equipment List.....	7
1.7. Description of Test Facility.....	10
1.8. EMS Performance Criteria.....	11
2. Power Line Conducted Emission Test.....	12
2.1. Test Standard and Limit.....	12
2.2. Test Setup.....	14
2.3. Test Procedure.....	14
2.4. Test Results.....	14
3. Radiated Emission Test (Below 1 GHz).....	17
3.1. Test Standard and Limit.....	17
3.2. Test Setup.....	19
3.3. Test Procedure.....	20
3.4. Test Results.....	20
4. Harmonic Current Test.....	23
4.1. Test Standard.....	23
4.2. Test Setup.....	23
4.3. Test Procedure.....	23
4.4. Test Results.....	23
5. Voltage Fluctuations & Flicker Test.....	24
5.1. Test Standard.....	24
5.2. Test Setup.....	24
5.3. Test Procedure.....	24
5.4. Test Results.....	24
6. Electrostatic Discharge Immunity Test.....	25
6.1. Test Specification.....	25
6.2. Test Setup.....	25
6.3. Test Procedure.....	25
6.4. Test Results.....	26
7. RF Field Strength Immunity Test.....	28
7.1. Test Specification.....	28
7.2. Test Setup.....	28
7.3. Test Procedure.....	29
7.4. Test Results.....	29



8. Electrical Fast Transient/Burst Immunity Test.....	31
8.1. Test Specification.....	31
8.2. Test Setup.....	31
8.3. Test Procedure.....	32
8.4. Test Results.....	32
9. Surge Immunity Test.....	34
9.1. Test Specification.....	34
9.2. Test Setup.....	34
9.3. Test Procedure.....	35
9.4. Test Results.....	35
10. Injected Currents Susceptibility Test.....	37
10.1. Test Specification.....	37
10.2. Test Setup.....	37
10.3. Test Procedure.....	38
10.4. Test Results.....	38
11. Power Frequency Magnetic Field Immunity Test.....	40
11.1. Test Specification.....	40
11.2. Test Setup.....	40
11.3. Test Procedure.....	40
11.4. Test Results.....	40
12. Voltage Dips and Interruptions Immunity Test.....	41
12.1. Test Specification.....	41
12.2. Test Setup.....	41
12.3. Test Procedure.....	41
12.4. Test Results.....	41
APPENDIX I -- TEST SETUP PHOTOGRAPH.....	43
APPENDIX II -- Photo documentation.....	47



TEST REPORT

Applicant : Acrel Co., Ltd.
Manufacturer : Jiangsu Acrel Electrical Manufacturing. Co., Ltd
Product Name : Power Meter
Test Model No. : ADL400-D
Reference Model No. : ADL400-U, ADL400-C, ADL400-F, ADL400, ADL400-FC
Trade Mark : N.A.
Rating(s) : 3×230/400V, 3×66/115V,
0.1-10(80)A, 0.1-0.5(80)A,
0.01-1(6)A, 3~10(80)A, 3~1(6)A, 0.01-0.05(6)A, 45-65Hz
Test Standard(s) : **EN IEC 61326-1: 2021;**
EN IEC 61000-3-2: 2019+A1:2021;
EN 61000-3-3: 2013+A1:2019+A2:2021;
(IEC 61000-4-2; IEC 61000-4-3; IEC 61000-4-4;
IEC 61000-4-5; IEC 61000-4-6; IEC 61000-4-8; IEC 61000-4-11)

The device described above is tested by Shenzhen Anbotek Compliance Laboratory Limited to determine the maximum emission levels emanating from the device and the severe levels of the device can endure and its performance criterion. The measurement results are contained in this test report and Shenzhen Anbotek Compliance Laboratory Limited is assumed full of responsibility for the accuracy and completeness of these measurements. Also, this report shows that the EUT (Equipment Under Test) is technically compliant with the EN IEC 61326-1, EN IEC 61000-3-2, EN 61000-3-3 requirements.

This report applies to above tested sample only and shall not be reproduced in part without written approval of Shenzhen Anbotek Compliance Laboratory Limited.

Date of Receipt: Feb. 28, 2023

Date of Test: Feb. 28~Mar. 13, 2023

Prepared By:

Yee Huang

(Yee Huang)

Approved & Authorized Signer:

KingKong Jin

(KingKong Jin)



1. General Information

1.1. Client Information

Applicant	:	Acrel Co., Ltd.
Address	:	No.253, Yulv Road, Jiading, Shanghai, China
Manufacturer	:	Jiangsu Acrel Electrical Manufacturing. Co., Ltd
Address	:	No.5, Dongmeng Road, Nanzha, Jiangyin, Jiangsu, China
Factory	:	Jiangsu Acrel Electrical Manufacturing. Co., Ltd
Address	:	No.5, Dongmeng Road, Nanzha, Jiangyin, Jiangsu, China

1.2. Description of Device (EUT)

Product Name	:	Power Meter
Test Model No.	:	ADL400-D
Reference Model No.	:	ADL400-U, ADL400-C, ADL400-F, ADL400, ADL400-FC (Note: All samples are the same except the model number & appearance, so we prepare "ADL400-U" for test only.)
Trade Mark	:	N.A.
Test Power Supply	:	AC3*230/400V,50Hz
Test Sample No.	:	1-1-1
Product Description	:	N/A
Remark: (1) For a more detailed features description, please refer to the manufacturer's specifications or the User's Manual.		

1.3. Auxiliary Equipment Used During Test

N/A	
-----	--



1.4. Description of Test Mode

Pretest Mode	Description
Mode 1	On

For Mode 1 Block Diagram of Test Setup



1.5. Test Summary

Test Items	Test Mode	Status
Power Line Conducted Emission Test	Mode 1	P
Radiated Emission Test (Below 1 GHz)	Mode 1	P
Radiated Emission Test (Above 1GHz)	/	N
Harmonic Current Test	Mode 1	P
Voltage Fluctuations & Flicker Test	Mode 1	P
Electrostatic Discharge Immunity Test	Mode 1	P
RF Field Strength Immunity Test	Mode 1	P
Electrical Fast Transient/Burst Immunity Test	Mode 1	P
Surge Immunity Test	Mode 1	P
Injected Currents Susceptibility Test	Mode 1	P
Power frequency Magnetic Field Immunity Test	/	N
Voltage Dips and Interruptions Immunity Test	Mode 1	P
P) Indicates "PASS". F) Indicates "Fail". N) Indicates "Not applicable".		



1.6. Test Equipment List Power Line Conducted Emission Test

Item	Equipment	Manufacturer	Model No.	Serial No.	Last Cal.	Cal. Interval
1.	L.I.S.N. Artificial Mains Network	Rohde & Schwarz	ENV216	100055	Oct. 23, 2022	1 Year
2.	Three Phase V-type Artificial Power Network	CYBERTEK	EM5040DT	E215040D T001	Jul. 05, 2022	1 Year
3.	EMI Test Receiver	Rohde & Schwarz	ESCI	100627	Oct. 13, 2022	1 Year
4.	RF Switching Unit	Compliance Direction	RSU-M2	38303	Oct. 22, 2022	1 Year
5.	Software Name EZ-EMC	Ferrari Technology	ANB-03A	N/A	N/A	N/A

 Radiated Emission Test (Below 1 GHz)

Item	Equipment	Manufacturer	Model No.	Serial No.	Last Cal.	Cal. Interval
1.	EMI Test Receiver	Rohde & Schwarz	ESCI	100627	Oct. 13, 2022	1 Year
2.	Pre-amplifier	Schwarzbeck	BBV-9745	9745-075	Oct. 23, 2022	1 Year
3.	Bilog Broadband Antenna	SCHWARZBECK	VULB 9163	01109	Oct. 16, 2022	3 Year
4.	Software Name EZ-EMC	Ferrari Technology	EMEC-3A1	N/A	N/A	N/A

 Radiated Emission Test (Above 1GHz)

Item	Equipment	Manufacturer	Model No.	Serial No.	Last Cal.	Cal. Interval
1.	EMI Test Receiver	Rohde & Schwarz	ESR26	101481	Oct. 23, 2022	1 Year
2.	Bilog Broadband Antenna	Schwarzbeck	VULB9163	VULB 9163-289	Oct. 23, 2022	1 Year
3.	Pre-amplifier	SONOMA	310N	186860	Oct. 23, 2022	1 Year
4.	Software Name EZ-EMC	Ferrari Technology	ANB-03A	N/A	N/A	N/A
5.	EMI Preamplifier	SKET Electronic	LNPA-0118G- 45	SKET-PA-0 02	Oct. 13, 2022	1 Year
6.	Double Ridged Horn Antenna	SCHWARZBECK	BBHA 9120D	02555	Oct. 16, 2022	3 Year



Harmonic Current and Flicker Test

Item	Equipment	Manufacturer	Model No.	Serial No.	Last Cal.	Cal. Interval
1.	Programmable AC Power source	IVYTECH	APS-5005A	632734	Oct. 23, 2022	1 Year
2.	Harmonic and Flicker Analyzer	EMC-PARTNER	HMONICS 1000-1P	164	Oct. 23, 2022	1 Year
3.	Harmonics-1000	N/A	Ed.3.0+4.0	N.A	N/A	N/A

 Electrostatic Discharge Immunity Test

Item	Equipment	Manufacturer	Model No.	Serial No.	Last Cal.	Cal. Interval
1.	ESD Simulators	emtest	ESD NX30.1	11936	Mar. 25, 2022	1 Year

 RF Field Strength Immunity Test

Item	Equipment	Manufacturer	Model No.	Serial No.	Last Cal.	Cal. Interval
1.	Signal Generator	Agilent	N5181A	MY5014310 7	Apr. 20, 2022	1 Year
2.	Power Meter	Agilent	E4417A	MY4510138 4	May 14, 2022	1 Year
3.	Amplifier	Micotop	MPA-80-100 0-600	MPA211031 8	Apr. 20, 2022	1 Year
4.	Amplifier	Micotop	MPA-1000-6 000-100	MPA211032 7	Apr. 20, 2022	1 Year
5.	Log.-Per.-Antenna	Schwarzbeck	VULP 9118E	01012	N/A	N/A
6.	Microwave Log.-Per. Antenna	Schwarzbeck	STLP 9149	00788	N/A	N/A
7.	Power Sensor	KEYSIGHT	E9323A	US40410647	Apr. 20, 2022	1 Year
8.	Power Sensor	KEYSIGHT	E9323A	MY5310000 7	Apr. 20, 2022	1 Year
9.	Electric field Probe	Narda S.T.S /PMM	EP 601	811ZX10351	Apr. 29, 2022	1 Year
10.	Software	EMtrace	EM 3	/	N/A	N/A

 Electrical Fast Transient/Burst Immunity Test

Item	Equipment	Manufacturer	Model No.	Serial No.	Last Cal.	Cal. Interval
1.	Surge Generator	TESEQ	NSG 3060	1480	Oct. 23, 2022	1 Year
2.	CDN	TESEQ	CDN 3061	1408	Oct. 23, 2022	1 Year
3.	EFT-Clamp	PRIMA	EFT-Clamp	/	Oct. 13, 2022	1 Year



Surge Immunity Test

Item	Equipment	Manufacturer	Model No.	Serial No.	Last Cal.	Cal. Interval
1.	Combined Wave Lightning Surge Simulator	3Ctest	CCS600	ES3771702	Jul. 05, 2022	1 Year
2.	Three Phase Power Coupling Network	3Ctest	SEPN69100 T	ES0801757	Jul. 05, 2022	1 Year
3.	Telecom port surge generator	PMI	TW101	190411	May 13, 2022	1 Year

 Injected Currents Susceptibility Test

Item	Equipment	Manufacturer	Model No.	Serial No.	Last Cal.	Cal. Interval
1.	C/S Conducted Immunity Test System	FRANKONIA	CIT-10	126A1196/20 12	Oct. 23, 2022	1 Year
2.	CDN	FRANKONIA	CDN - M2+ M3	A2210178/20 12	Oct. 23, 2022	1 Year
3.	6dB Attenuator	FRANKONIA	DAM 26W	1172202	Oct. 23, 2022	1 Year
4.	CIT-10	FRANKONIA	Version1.1.7	N/A	N/A	N/A
5.	EM-Clamp	FRANKONIA	EMCL-20	18101728-01 03	May 17, 2022	1 Year

 Power frequency Magnetic Field Immunity Test

Item	Equipment	Manufacturer	Model No.	Serial No.	Last Cal.	Cal. Interval
1.	Power Frequency Magnetic Field Generator	EVERFINE	EMS61000-8 K	906002	Oct. 23, 2022	1 Year

 Voltage Dips and Interruptions Immunity Test

Item	Equipment	Manufacturer	Model No.	Serial No.	Last Cal.	Cal. Interval
1.	CYCLE SAG Simulator	PRIMA	DRP61011A G	PR12046234	Oct. 23, 2022	1 Year



1.7. Description of Test Facility

The test facility is recognized, certified, or accredited by the following organizations:

FCC-Registration No.: 184111

Shenzhen Anbotek Compliance Laboratory Limited, EMC Laboratory has been registered and fully described in a report filed with the (FCC) Federal Communications Commission. The acceptance letter from the FCC is maintained in our files. Registration No. 184111.

ISED-Registration No.: 8058A

Shenzhen Anbotek Compliance Laboratory Limited, EMC Laboratory has been registered and fully described in a report filed with the (ISED) Innovation, Science and Economic Development Canada. The acceptance letter from the ISED is maintained in our files. Registration 8058A.

Test Location

Shenzhen Anbotek Compliance Laboratory Limited.

1/F, Building D, Sogood Science and Technology Park, Sanwei community, Hangcheng Street, Bao'an District, Shenzhen, Guangdong, China.518128



1.8. EMS Performance Criteria

Performance criterion A

The equipment shall continue to operate as intended during and after the test. No degradation of performance or loss of function is allowed below a performance level specified in the user documentation, when the equipment is used as intended. In the case of applying immunity tests with continuous electromagnetic phenomena, the performance level may be replaced by a permissible loss of performance which shall recover, v/ithout user intervention. A permissible loss of performance is allowed within the performance level only when this information is clearly provided to the end user via documentation, such as the product user manual. No change in the operating state is allowed nor is loss of data.

Performance criterion B

The equipment shall continue to operate as intended after the test. No degradation of performance or loss of function is allowed below a performance level specified in the user documentation, when the equipment is used as intended. During the test, the equipment performance level may be replaced by a permissible loss of performance if such loss of performance is detailed in the EMC test plan. A permissible loss of performance is allowed within the performance level only when this information is clearly provided to the end user via documentation, such as the product user manual. An unintended change of the operating state is allowed if self-recoverable. No loss of stored data is allowed.

Performance criterion C

Loss of function is allowed, provided the function is self-recoverable or can be restored by the operation of the controls. Recovery procedure shall be included in the user documentation. No permanent damage to the equipment is allowed.



2. Power Line Conducted Emission Test

2.1. Test Standard and Limit

Test Standard:	EN IEC 61326-1
----------------	----------------

Limits for conducted emission at the AC mains power ports of Class A Group 1 equipment

Frequency range (MHz)	Rated power ≤ 20KVA		20KVA < Rated power ≤ 75KVA		75KVA < Rated power	
	QP(dBuV)	AVG(dBuV)	QP(dBuV)	AVG(dBuV)	QP(dBuV)	AVG(dBuV)
0.15 ~ 0.50	79	66	100	90	130	120
0.50 ~ 5.00	73	60	86	76	125	115
5.00 ~ 30.00	73	60	90 ~ 73*	80 ~ 60*	115	105

Remark:

- (1) The lower limit shall apply at the transition frequencies.
- (2) The limit decreases linearly with the logarithm of the frequency in the range 5.00 MHz to 30.00 MHz.

Limits for conducted emission at the DC power ports of Class A Group 1 equipment

Frequency range (MHz)	Rated power ≤ 20KVA		20KVA < Rated power ≤ 75KVA		75KVA < Rated power	
	QP(dBuV)	AVG(dBuV)	QP(dBuV)	AVG(dBuV)	QP(dBuV)	AVG(dBuV)
0.15 ~ 5.00	97 ~ 89*	84 ~ 76*	116 ~ 106*	106 ~ 96*	132 ~ 122*	122 ~ 112*
5.00 ~ 30.00	89	76	106 ~ 89*	96 ~ 76*	122 ~ 105*	112 ~ 92*

Remark:

The limit decreases linearly with the logarithm of the frequency in the range 0.15 MHz to 30.00 MHz.

Limits for conducted emission at the AC mains power ports of Class B Group 1 equipment

Frequency range (MHz)	Limit (dBuV)	
	Quasi-peak	Average
0.15 ~ 0.50	66 ~ 56*	56 ~ 46*
0.50 ~ 5.00	56	46
5.00 ~ 30.00	60	50

Remark:

- (1) The lower limit shall apply at the transition frequencies.
- (2) The limit decreases linearly with the logarithm of the frequency in the range 0.15 MHz to 0.50 MHz.



Limits for conducted emission at the DC power ports of Class B Group 1 equipment

Frequency range (MHz)	Limit (dBuV)	
	Quasi-peak	Average
0.15 ~ 0.50	84 ~ 74*	74 ~ 64*
0.50 ~ 30.00	74	64

Remark:

The limit decreases linearly with the logarithm of the frequency in the range 0.15 MHz to 0.50 MHz.

 Limits for conducted emission at the AC mains power ports of Class B Group 2 equipment

Frequency range (MHz)	Limit (dBuV)	
	Quasi-peak	Average
0.15 ~ 0.50	66 ~ 56*	56 ~ 46*
0.50 ~ 5.00	56	46
5.00 ~ 30.00	60	50

Remark:

(1) The lower limit shall apply at the transition frequencies.

(2) The limit decreases linearly with the logarithm of the frequency in the range 0.15 MHz to 0.50 MHz.

 Limits for conducted emission at the AC mains power ports of Class A Group 2 equipment

Frequency range (MHz)	Limit of Rated power ≤ 75KVA (dBuV)		Limit of Rated power > 75KVA (dBuV)	
	Quasi-peak	Average	Quasi-peak	Average
0.15 ~ 0.50	100	90	130	120
0.50 ~ 5.00	86	76	125	115
5.00 ~ 30.00	90 ~ 73*	80 ~ 60*	115	105

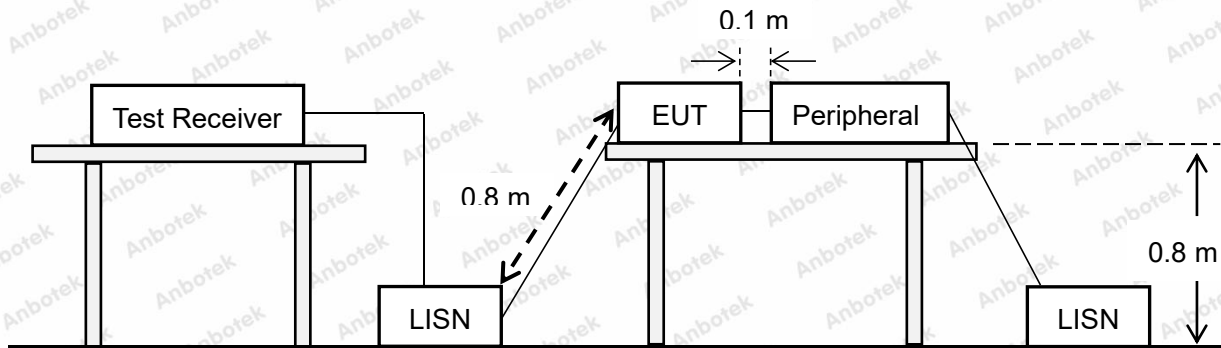
Remark:

(1) The lower limit shall apply at the transition frequencies.

(2) The limit decreases linearly with the logarithm of the frequency in the range 5.00 MHz to 30.00 MHz.



2.2. Test Setup



2.3. Test Procedure

The table-top EUT is placed on a non-conductive table 0.8 m above the horizontal ground reference plane, and the back of the EUT is 0.4 m away from the vertical ground reference plane, and at least 0.8 m from any other metal surface or ground plane. The floor-standing EUT is placed on an insulating support 0.1 m above the horizontal ground reference plate, at least 0.8 m away from other metal objects.

Connect EUT to the power mains through an LISN. Where the mains cable supplied by the manufacturer is longer than 1 m, the excess should be folded at the center into a bundle no longer than 0.4 m, so that its length is shortened to 1 m. All the peripherals are connecting to the other LISN.

The initial testing identified the frequency that has the highest disturbance relative to the limit while operating the EUT in typical modes of operation and cable positions in a test setup representative of typical system configuration.

The identification of the frequency of highest disturbance with respect to the limit was found by investigating disturbances at a number of significant frequencies. The probable frequency of maximum disturbance had been found and that the associated cable and EUT configuration and mode of operation had been identified.

Set the test-receiver to quasi peak detect function and average detect function, and to measure the conducted emissions values.

2.4. Test Results

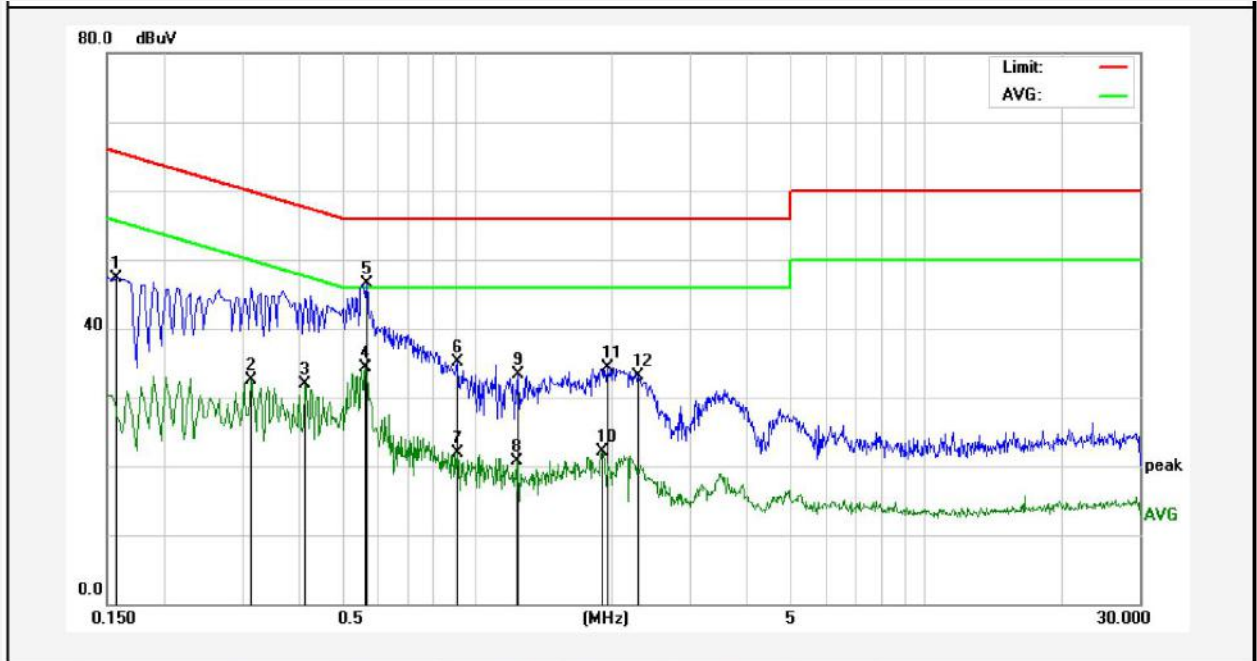
PASS

The test curves are shown in the following pages.



Power Line Conducted Test Data

Test Site: 1# Shielded Room
 Test Specification: AC3*230/400V,50Hz
 Comment: Live Line
 Temp.: 23.5°C Hum.: 45%



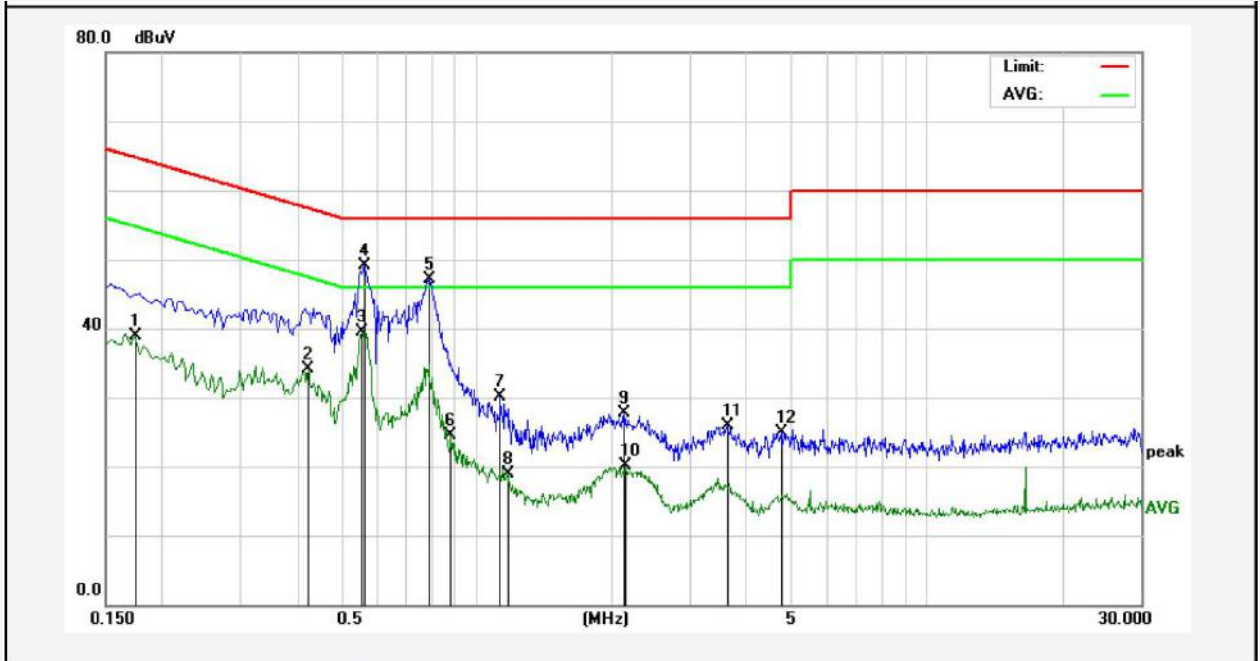
No.	Freq. (MHz)	Reading (dBuV)	Factor (dB)	Result (dBuV)	Limit (dBuV)	Over Limit (dB)	Detector	Remark
1	0.1580	37.73	9.59	47.32	65.56	-18.24	QP	
2	0.3140	22.72	9.77	32.49	49.86	-17.37	AVG	
3	0.4140	22.16	9.77	31.93	47.57	-15.64	AVG	
4	0.5660	24.51	9.85	34.36	46.00	-11.64	AVG	
5	0.5700	36.62	9.85	46.47	56.00	-9.53	QP	
6	0.9060	25.26	9.84	35.10	56.00	-20.90	QP	
7	0.9060	12.08	9.84	21.92	46.00	-24.08	AVG	
8	1.2300	10.96	9.84	20.80	46.00	-25.20	AVG	
9	1.2420	23.43	9.84	33.27	56.00	-22.73	QP	
10	1.9020	12.33	9.85	22.18	46.00	-23.82	AVG	
11	1.9620	24.52	9.85	34.37	56.00	-21.63	QP	
12	2.2860	23.19	9.87	33.06	56.00	-22.94	QP	

Note: Result = Reading + Factor Over Limit = Result - Limit



Power Line Conducted Test Data

Test Site: 1# Shielded Room
 Test Specification: AC3*230/400V,50Hz
 Comment: Neutral Line
 Temp.: 23.5°C Hum.: 45%



No.	Freq. (MHz)	Reading (dBuV)	Factor (dB)	Result (dBuV)	Limit (dBuV)	Over Limit (dB)	Detector	Remark
1	0.1740	29.39	9.59	38.98	54.76	-15.78	AVG	
2	0.4220	24.41	9.78	34.19	47.41	-13.22	AVG	
3	0.5580	29.61	9.85	39.46	46.00	-6.54	AVG	
4	0.5660	39.27	9.85	49.12	56.00	-6.88	QP	
5	0.7900	37.35	9.84	47.19	56.00	-8.81	QP	
6	0.8780	14.63	9.84	24.47	46.00	-21.53	AVG	
7	1.1340	20.16	9.85	30.01	56.00	-25.99	QP	
8	1.1780	9.11	9.84	18.95	46.00	-27.05	AVG	
9	2.1380	17.88	9.86	27.74	56.00	-28.26	QP	
10	2.1460	10.16	9.86	20.02	46.00	-25.98	AVG	
11	3.6140	16.03	9.89	25.92	56.00	-30.08	QP	
12	4.7540	15.19	9.78	24.97	56.00	-31.03	QP	

Note: Result = Reading + Factor Over Limit = Result - Limit



3. Radiated Emission Test (Below 1 GHz)

3.1. Test Standard and Limit

Test Standard	EN IEC 61326-1
---------------	----------------

Limit for radiated emissions at frequencies up to 1 GHz for class A Group 1 equipment

Frequency (MHz)	Limit of Rated power $\leq 20\text{KVA}$ (3m)	Limit of Rated power $> 20\text{KVA}$ (3m)
	Quasi-peak (dB $\mu\text{V/m}$)	Quasi-peak (dB $\mu\text{V/m}$)
30 ~ 230	50	60
230 ~ 1000	57	60

Remark: The lower limit shall apply at the transition frequencies.

Limit for radiated emissions at frequencies up to 1 GHz for class B Group 1 equipment

Frequency (MHz)	Distance (Meters)	Field Strengths Limit (dB $\mu\text{V/m}$)
30 ~ 230	3	40
230 ~ 1000	3	47

Remark: The lower limit shall apply at the transition frequencies.

Limit for radiated emissions at frequencies up to 1 GHz for class B Group 2 equipment

Frequency (MHz)	Limit (3m)		
	QP (dB $\mu\text{V/m}$)	AVG (dB $\mu\text{V/m}$)	QP (dB $\mu\text{A/m}$)
0.15 ~ 30	-	-	39 ~ 3*
30 ~ 80.872	40	35	-
80.872 ~ 81.848	60	55	-
81.848 ~ 134.786	40	35	-
134.786 ~ 136.414	60	55	-
136.414 ~ 230	40	35	-
230 ~ 1000	47	42	-

Remark:

(1) The lower limit shall apply at the transition frequencies.

(2) The limit decreases linearly with the logarithm of the frequency in the range 0.15 MHz to 30 MHz.



Limit for radiated emissions at frequencies up to 1 GHz for class B Group 2 equipment

Frequency (MHz)	Limit (3m)	
	QP (dB μ V/m)	QP (dB μ A/m)
0.15 ~ 0.49	-	82
0.49 ~ 1.705	-	72
1.705 ~ 2.194	-	77
2.194 ~ 3.95	-	68
3.95 ~ 11	-	68 ~ 28.5*
11 ~ 20	-	28.5
20 ~ 30	-	18.5
30 ~ 47	78	-
47 ~ 53.91	60	-
53.91 ~ 54.56	60	-
54.56 ~ 68	60	-
68 ~ 80.872	73	-
80.872 ~ 81.848	88	-
81.848 ~ 87	73	-
87 ~ 134.786	70	-
134.786 ~ 136.414	80	-
136.414 ~ 156	70	-
156 ~ 174	84	-
174 ~ 188.7	60	-
188.7 ~ 190.979	70	-
190.979 ~ 230	60	-
230 ~ 400	70	-
400 ~ 470	73	-
470 ~ 1000	70	-

Remark:

- (1) The lower limit shall apply at the transition frequencies.
- (2) The limit decreases linearly with the logarithm of the frequency in the range 3.95 MHz to 11 MHz.



Limit for radiated emissions at frequencies up to 1 GHz for class A EDM and arc welding equipment

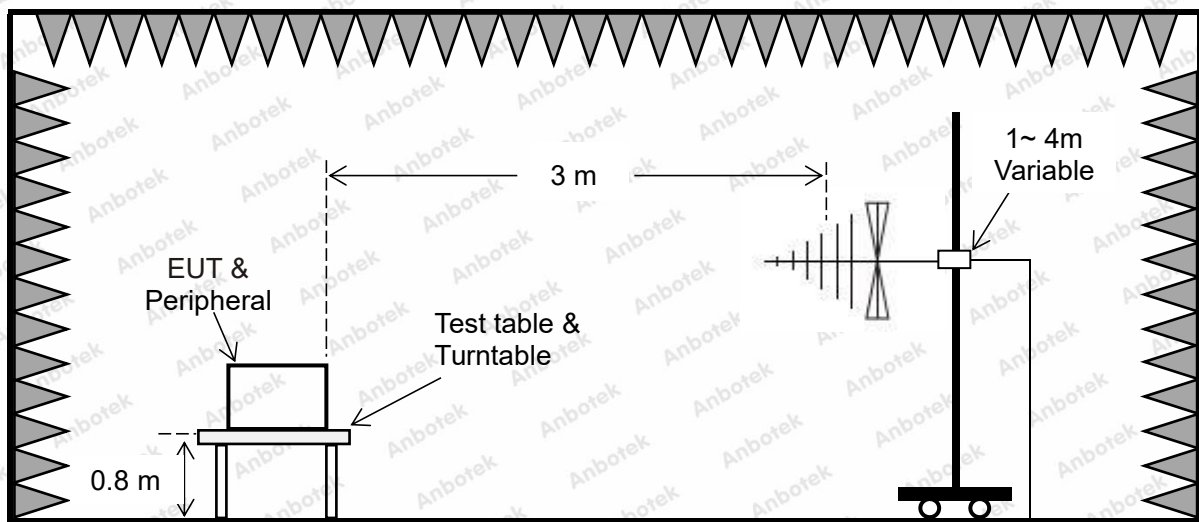
Frequency (MHz)	Distance (Meters)	Field Strengths Limit (dB μ V/m)
30 ~ 230	3	90 ~ 70*
230 ~ 1000	3	70

Remark:

The limit decreases linearly with the logarithm of the frequency in the range 30 MHz to 230 MHz.

3.2. Test Setup

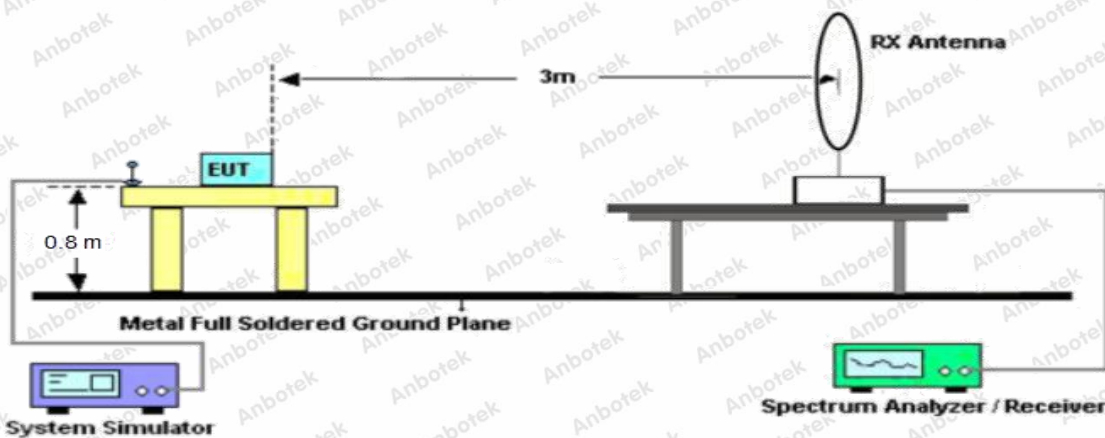
30 MHz-1 GHz



Test Receiver

Pre-Amplifier

0.15 MHz-30 MHz



3.3. Test Procedure

The table-top EUT is placed on a non-conductive table 0.8 m above the horizontal ground reference plane. The floor-standing EUT is placed on an insulating support 0.1 m above the horizontal ground reference plane.

The EUT was set 3 m away from the receiving antenna that was mounted on a non-conductive mast. The antenna can move up and down between 1 to 4 m to find out the maximum emission level(The height of the loop antenna is fixed at 1.5m).

The turntable can rotate 360 degree to determine the position of the maximum emission level.

The initial testing identified the frequency that has the highest disturbance relative to the limit while operating the EUT in typical modes of operation and cable positions in a test setup representative of typical system configuration.

The identification of the frequency of highest emission with respect to the limit was found by investigating emissions at a number of significant frequencies. The probable frequency of maximum emission had been found and that the associated cable and EUT configuration and mode of operation had been identified.

In the test frequency range of 0.15MHz-30MHz, the analytical bandwidth of the receiver is set to 9KHz, and in the test frequency range of 30MHz-1000MHz, the analytical bandwidth of the receiver is set to 120KHz.

3.4. Test Results

PASS

The test curves are shown in the following pages.



Test item: Radiation Test Polarization: Horizontal
 Standard: (RE)EN IEC 61326-1 Power Source: AC3*230/400V,50Hz
 Frequency Range: 30MHz ~ 1000MHz Temp.(°C)/Hum.(%RH): 23.5(°C)/48%RH
 Distance: 3m



No.	Freq. (MHz)	Reading (dBuV)	Factor ()	Result (dBuV/m)	Limit (dBuV/m)	Over Limit (dB)	Detector	Height (cm)	degree (deg)	Remark
1	64.3201	29.26	-19.41	9.85	40.00	-30.15	QP			
2	137.9028	42.57	-21.24	21.33	40.00	-18.67	QP			
3	270.8493	32.79	-15.56	17.23	47.00	-29.77	QP			
4	398.3312	32.25	-12.46	19.79	47.00	-27.21	QP			
5	466.4164	31.18	-11.18	20.00	47.00	-27.00	QP			
6	940.4800	28.68	-4.08	24.60	47.00	-22.40	QP			

Note: Result= Reading + Factor Over Limit=Result-Limit



Test item: Radiation Test Polarization: Vertical
 Standard: (RE)EN IEC 61326-1 Power Source: AC3*230/400V,50Hz
 Frequency Range: 30MHz ~ 1000MHz Temp.(°C)/Hum.(%RH): 23.5(°C)/48%RH
 Distance: 3m



No.	Freq. (MHz)	Reading (dBuV)	Factor ()	Result (dBuV/m)	Limit (dBuV/m)	Over Limit (dB)	Detector	Height (cm)	degree (deg)	Remark
1	35.7490	37.16	-17.87	19.29	40.00	-20.71	QP			
2	56.8914	37.28	-17.53	19.75	40.00	-20.25	QP			
3	137.9028	43.23	-21.24	21.99	40.00	-18.01	QP			
4	355.4273	31.45	-13.50	17.95	47.00	-29.05	QP			
5	478.8456	31.04	-10.95	20.09	47.00	-26.91	QP			
6	957.1148	28.60	-3.91	24.69	47.00	-22.31	QP			

Note: Result= Reading + Factor Over Limit=Result-Limit

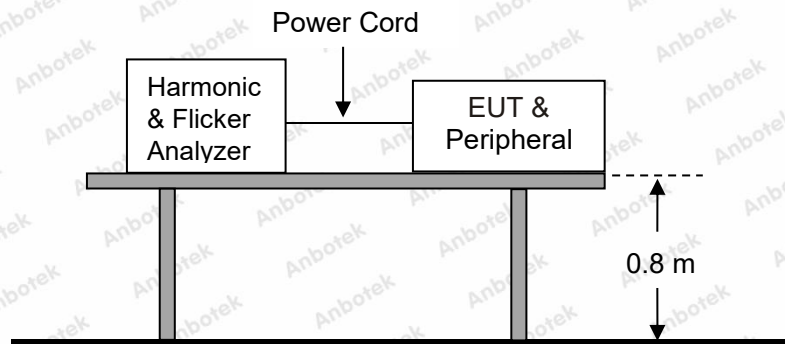


4. Harmonic Current Test

4.1. Test Standard

Test Standard:	EN IEC 61000-3-2
----------------	------------------

4.2. Test Setup



4.3. Test Procedure

The table-top EUT is placed on the top of a wooden table 0.8 m above the ground (0.1 m for the floor-standing EUT) and operated to produce the maximum harmonic components under normal operating conditions for each successive harmonic component in turn. The correspondent test program of test instrument to measure the current harmonics emanated from EUT is chosen. The measure time shall be not less than the necessary for the EUT to be exercised.

4.4. Test Results

PASS

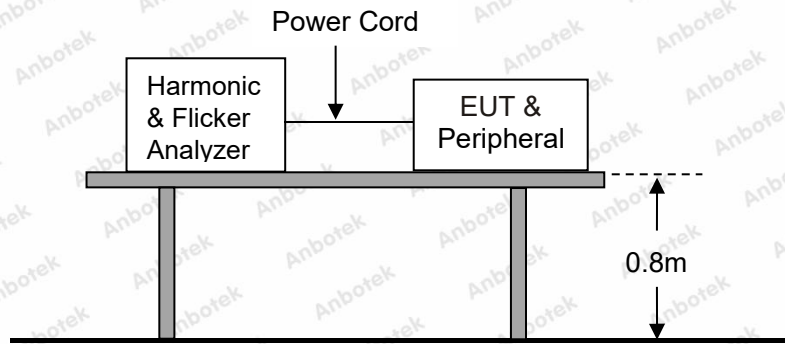


5. Voltage Fluctuations & Flicker Test

5.1. Test Standard

Test Standard:	EN 61000-3-3
----------------	--------------

5.2. Test Setup



5.3. Test Procedure

The table-top EUT is placed on the top of a wooden table 0.8 m above the ground (0.1 m for the floor-standing EUT) and operated to produce the most unfavorable sequence of voltage changes under normal conditions during the flicker measurement. The observation period for short-term flicker indicator is 10 minutes and the observation period for long-term flicker indicator is 2 hours.

5.4. Test Results

PASS

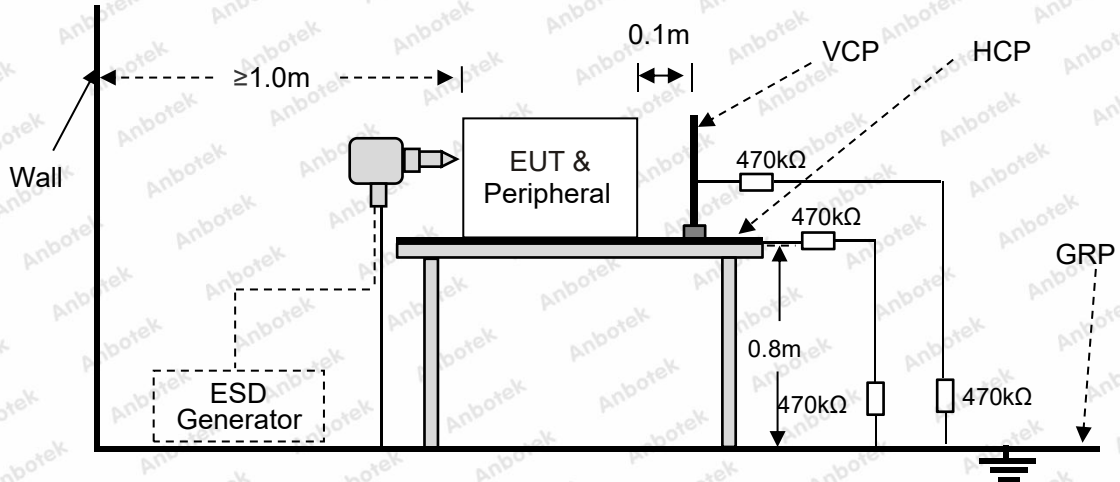


6. Electrostatic Discharge Immunity Test

6.1. Test Specification

Test Standard :	EN IEC 61326-1	
Basic standard :	IEC 61000-4-2: 2008	
Performance criteria:	B	
Test Level :	± 8kV (Air Discharge)	± 4kV (Contact Discharge)

6.2. Test Setup



6.3. Test Procedure

a. In the case of air discharge testing, the climatic conditions shall be within the following ranges:

- Ambient temperature: 15°C to 35°C;
- Relative humidity: 30% to 60%;
- Atmospheric pressure: 86 kPa (860 mbar) to 106 kPa (1060 mbar)

b. In the case of contact discharges, the tip of the discharge electrode shall touch the EUT before the discharge switch is operated.

c. In the case of painted surface covering a conducting substrate, the following procedure shall be adopted:

- If the coating is not declared to be an insulating coating by the equipment manufacturer, then the pointed tip of the generator shall penetrate the coating so as to make contact with the conducting substrate.
- Coating declared as insulating by the manufacturer shall only be submitted to the air discharge.
- The contact discharge test shall not be applied to such surfaces.



d. In the case of air discharges, the round discharge tip of the discharge electrode shall be approached as fast as possible (without causing mechanical damage) to touch the EUT. After each discharge, the ESD generator (discharge electrode) shall be removed from the EUT. The generator is then retriggered for a new single discharge. This procedure shall be repeated until the discharges are completed. In the case of an air discharge test, the discharge switch, which is used for contact discharge, shall be closed.

e. The test voltage shall be increased from the minimum to the selected test severity level, in order to determine any threshold of failure. The final test level should not exceed the product specification value in order to avoid damage to the equipment.

f. The test shall be performed with both air discharge and contact discharge. The test shall be performed with single discharges. On each pre-selected point at least 10 single discharges (in the most sensitive polarity) shall be applied. For the time interval between successive single discharges an initial value of 1 s is recommended. Longer intervals may be necessary to determine whether a system failure has occurred.

g. Ensure that the applied charge on the EUT has been dis-charged before next ESD pulse.

6.4. Test Results

PASS

Please refer to the following page.



Electrostatic Discharge Test Results

Test Result:	<input checked="" type="checkbox"/> Pass <input type="checkbox"/> Fail	Temperature:	22.3°C
Power Supply:	AC3*230/400V,50Hz	Humidity:	46%
Location		Kind A-Air Discharge C-Contact Discharge	Result
Air discharge: ±2.0 kV, ±4.0 kV, ±8.0 kV		Contact discharge: ±4.0 kV	
Slot	4 points	A	<input checked="" type="checkbox"/> A <input type="checkbox"/> B <input type="checkbox"/> C
Screen	4 points	A	<input checked="" type="checkbox"/> A <input type="checkbox"/> B <input type="checkbox"/> C
Button	4 points	A	<input checked="" type="checkbox"/> A <input type="checkbox"/> B <input type="checkbox"/> C
Light	2 points	A	<input checked="" type="checkbox"/> A <input type="checkbox"/> B <input type="checkbox"/> C
HCP	4 points	C	<input checked="" type="checkbox"/> A <input type="checkbox"/> B <input type="checkbox"/> C
VCP of the front	4 points	C	<input checked="" type="checkbox"/> A <input type="checkbox"/> B <input type="checkbox"/> C
VCP of the rear	4 points	C	<input checked="" type="checkbox"/> A <input type="checkbox"/> B <input type="checkbox"/> C
VCP of the left	4 points	C	<input checked="" type="checkbox"/> A <input type="checkbox"/> B <input type="checkbox"/> C
VCP of the right	4 points	C	<input checked="" type="checkbox"/> A <input type="checkbox"/> B <input type="checkbox"/> C
Note: N/A			

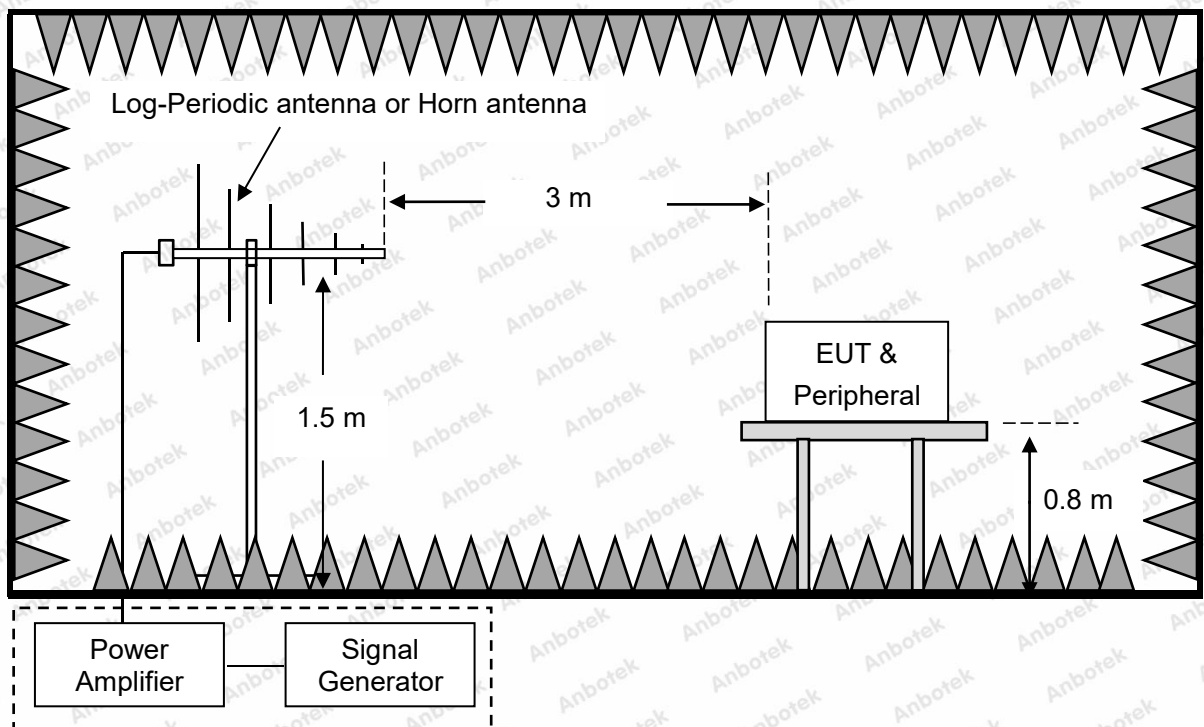


7. RF Field Strength Immunity Test

7.1. Test Specification

Test Standard:	EN IEC 61326-1	
Basic standard:	IEC 61000-4-3: 2020	
Test level:	<input checked="" type="checkbox"/> Basic Requirements	80MHz - 1GHz & 3V/m; Performance criteria:A 1.4GHz - 6GHz & 3V/m; Performance criteria:A
	<input type="checkbox"/> Requirements for industrial sites	80MHz - 1GHz & 10V/m; Performance criteria:A 1.4GHz - 6GHz & 3V/m; Performance criteria:A
	<input type="checkbox"/> Requirements for controlled electromagnetic environment	80MHz - 1GHz & 1V/m; Performance criteria:A 1.4GHz - 6GHz & 1V/m; Performance criteria:A
Modulation:	1kHz Sine Wave, 80%, AM Modulation	
Frequency Step:	1 % of preceding frequency value	
Polarity of Antenna:	Horizontal and Vertical	
Test Distance:	3 m	
Antenna Height:	1.5 m	
Dwell Time:	at least 0.5s	

7.2. Test Setup



7.3. Test Procedure

The procedure defined in this part requires the generation of electromagnetic fields within which the test sample is placed and its operation observed. To generate fields that are useful for simulation of actual (field) conditions may require significant antenna drive power and the resultant high field strength levels. To comply with local regulations and to prevent biological hazards to the testing personnel, it is recommended that these tests be carried out in a shielded enclosure or semi-anechoic chamber.

a. The antenna is placed 3 m from the equipment. The required field strength is determined by placing the field strength meter(s) on top of or directly alongside the equipment under test and monitoring the field strength meter via a remote field strength indicator outside the enclosure while adjusting the continuous-wave to the antenna.

b. The test shall normally be performed with the generating antenna facing each side of the EUT. When equipment can be used in different orientations (i.e. vertical or horizontal) all sides shall be exposed to the field during the test. When technically justified, some EUTs can be tested by exposing fewer faces to the generating antenna. In other cases, as determined for example by the type and size of EUT or the frequencies of test, more than four azimuths may need to be exposed.

c. The polarization of the field generated by each antenna necessitates testing each selected side twice, once with the antenna positioned vertically and again with the antenna positioned horizontally.

d. The step size of the frequency is set to 1%. The dwell time at each frequency shall not be less than the time necessary for the EUT to be exercised and to be able to respond. However, the dwell time should not exceed 5 s at each of the frequencies during the scan.

7.4. Test Results

PASS

Please refer to the following page.



RF Field Strength Susceptibility Test Results

Test Result:	<input checked="" type="checkbox"/> Pass <input type="checkbox"/> Fail	Temperature:	22.9℃		
Power Supply:	AC3*230/400V,50Hz	Humidity:	51%		
Frequency Range	Antenna Polarity	R.F. Field Strength	Dwell Time	Azimuth	Result
80 MHz ~ 1000 MHz	H / V	<input type="checkbox"/> 10 V/m <input checked="" type="checkbox"/> 3 V/m <input type="checkbox"/> 1 V/m	1s	Front	<input checked="" type="checkbox"/> A <input type="checkbox"/> B <input type="checkbox"/> C
				Rear	
				Left	
				Right	
1.4 GHz ~ 6 GHz	H / V	<input checked="" type="checkbox"/> 3 V/m <input type="checkbox"/> 1 V/m	1s	Front	<input checked="" type="checkbox"/> A <input type="checkbox"/> B <input type="checkbox"/> C
				Rear	
				Left	
				Right	
Note: N/A					



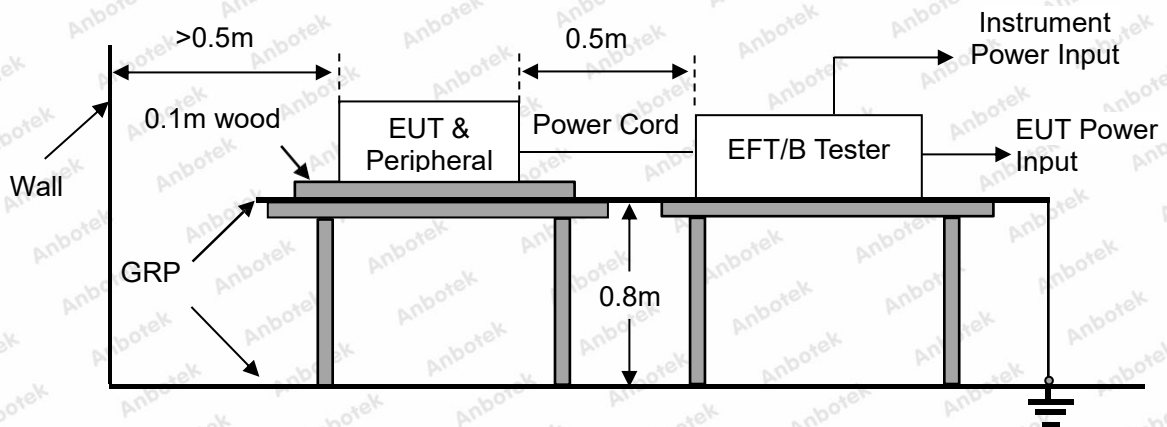
8. Electrical Fast Transient/Burst Immunity Test

8.1. Test Specification

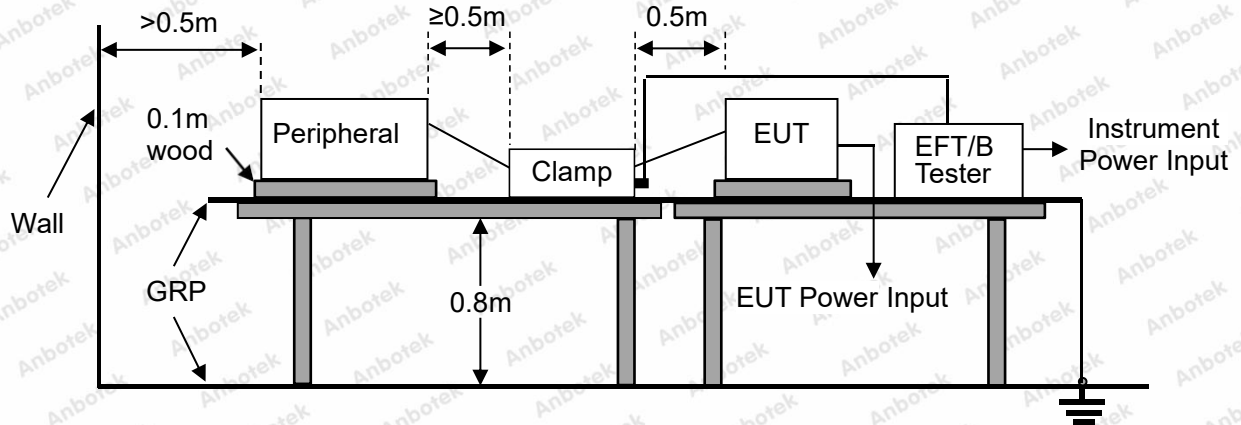
Test Standard:		EN IEC 61326-1
Basic standard:		IEC 61000-4-4: 2012
Performance criteria:		B
Test Level	☒ Basic Requirements	<input checked="" type="checkbox"/> 1 kV, AC mains power ports
		<input type="checkbox"/> 1 kV, DC power ports
		<input type="checkbox"/> 0.5 kV, I/O ports(Including functional earth)
		<input type="checkbox"/> 1 kV, I/O ports(Connected directly to mains supply)
	☐ Requirements for industrial sites	<input type="checkbox"/> 2 kV, AC mains power ports
		<input type="checkbox"/> 2 kV, DC power ports
		<input type="checkbox"/> 1 kV, I/O ports(Including functional earth)
		<input type="checkbox"/> 2 kV, I/O ports(Connected directly to mains supply)
	☐ Requirements for controlled electromagnetic environment	<input checked="" type="checkbox"/> 1 kV, AC mains power ports
		<input type="checkbox"/> 1 kV, DC power ports
		<input type="checkbox"/> 0.5 kV, I/O ports(Including functional earth)

8.2. Test Setup

AC mains power ports and DC network power ports:



I/O ports:



8.3. Test Procedure

The table-top EUT is placed on a table that is 0.8 m height, a ground reference plane is placed on the table, and uses 0.1 m insulation between the EUT and ground reference plane. The floor-standing EUT is placed on a ground reference plane and insulated from it by an insulating support with a thickness of 0.1 m. This reference ground plane shall project beyond the EUT by at least 0.1 m on all sides and the minimum distance between EUT and all other conductive structure, except the ground plane beneath the EUT, shall be more than 0.5 m.

All cables to the EUT shall be placed on the insulation support 0.1 m above the ground reference plane. Cables not subject to electrical fast transients shall be routed as far as possible from the cable under test to minimize the coupling between the cables.

8.4. Test Results

PASS

Please refer to the following page.



Electrical Fast Transient/Burst Test Results

Test Result:	<input checked="" type="checkbox"/> Pass <input type="checkbox"/> Fail	Temperature:	22.5°C	
Power Supply:	AC3*230/400V,50Hz	Humidity:	48%	
Ports	Polarity	Inject Time(s)	Test Voltage (kV)	Result
AC mains power ports	±	120 s	<input checked="" type="checkbox"/> 1.0 kV <input type="checkbox"/> 2.0 kV	<input checked="" type="checkbox"/> A <input type="checkbox"/> B <input type="checkbox"/> C
DC power ports	±	120 s	<input type="checkbox"/> 1.0 kV <input type="checkbox"/> 2.0 kV	<input type="checkbox"/> A <input type="checkbox"/> B <input type="checkbox"/> C
I/O ports	±	120 s	<input type="checkbox"/> 0.5 kV <input type="checkbox"/> 1.0 kV	<input type="checkbox"/> A <input type="checkbox"/> B <input type="checkbox"/> C
Note: N/A				

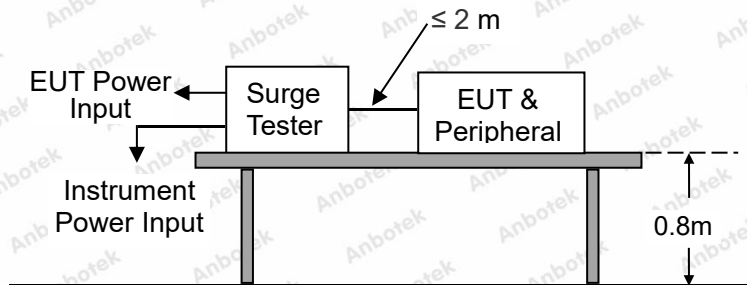


9. Surge Immunity Test

9.1. Test Specification

Test Standard:		EN IEC 61326-1
Basic standard:		IEC 61000-4-5: 2014+A1:2017
Performance criteria:		B
Test level:	<input checked="" type="checkbox"/> Basic Requirements	<input checked="" type="checkbox"/> AC mains power ports; Line - Line/0.5KV; Line - Ground/1KV
		<input type="checkbox"/> DC power ports; Line - Line/0.5KV; Line - Ground/1KV
		<input type="checkbox"/> I/O ports(Including functional earth); Line - Ground/1KV
		<input type="checkbox"/> I/O ports(Connected directly to mains supply); Line - Line/0.5KV; Line - Ground/1KV
	<input type="checkbox"/> Requirements for industrial sites	<input type="checkbox"/> AC mains power ports; Line - Line/1KV; Line - Ground/2KV
		<input type="checkbox"/> DC power ports; Line - Line/1KV; Line - Ground/2KV
		<input type="checkbox"/> I/O ports(Including functional earth); Line - Ground/1KV
		<input type="checkbox"/> I/O ports(Connected directly to mains supply); Line - Line/1KV; Line - Ground/2KV
	<input type="checkbox"/> Requirements for controlled electromagnetic environment	<input type="checkbox"/> AC mains power ports; Line - Line/0.5KV; Line - Ground/1KV
Number of surges		5 (for each combination of parameters)
Repetition rate		1 minute / time
Polarity:		Positive / Negative
Phase angle:		90°, 270° (Only AC mains power ports)

9.2. Test Setup



9.3. Test Procedure

Table-top EUT is placed on a table of 0.8 m heights above a metal ground reference plane. Floor standing EUT is placed on a ground reference plane and insulated from it by an insulating support with a thickness of 0.1 m. The length of the power cord between the EUT and the coupling/decoupling network is not more than 2 m, and the length of the interconnection line between the EUT and the coupling/decoupling network is not more than 2 m. The tests were done at repetition rate 1 per minute.

9.4. Test Results

PASS

Please refer to the following page.



Surge Immunity Test Results

Test Result:	<input checked="" type="checkbox"/> Pass <input type="checkbox"/> Fail		Temperature :	22.5°C	
Power Supply :	AC3*230/400V,50Hz		Humidity :	48%	
Location	Polarity	Phase Angle	Number of Pulse	Pulse Voltage (kV)	Result
<input checked="" type="checkbox"/> AC power port					
L1-L2	±	<input checked="" type="checkbox"/> 0° <input checked="" type="checkbox"/> 90° <input checked="" type="checkbox"/> 180° <input checked="" type="checkbox"/> 270°	5	<input checked="" type="checkbox"/> 0.5 kV <input type="checkbox"/> 1 kV	<input checked="" type="checkbox"/> A <input type="checkbox"/> B <input type="checkbox"/> C
L1-L3	±	<input checked="" type="checkbox"/> 0° <input checked="" type="checkbox"/> 90° <input checked="" type="checkbox"/> 180° <input checked="" type="checkbox"/> 270°	5	<input checked="" type="checkbox"/> 0.5 kV <input type="checkbox"/> 1 kV	<input checked="" type="checkbox"/> A <input type="checkbox"/> B <input type="checkbox"/> C
L2-L3	±	<input checked="" type="checkbox"/> 0° <input checked="" type="checkbox"/> 90° <input checked="" type="checkbox"/> 180° <input checked="" type="checkbox"/> 270°	5	<input checked="" type="checkbox"/> 0.5 kV <input type="checkbox"/> 1 kV	<input checked="" type="checkbox"/> A <input type="checkbox"/> B <input type="checkbox"/> C
L1-N	±	<input checked="" type="checkbox"/> 0° <input checked="" type="checkbox"/> 90° <input checked="" type="checkbox"/> 180° <input checked="" type="checkbox"/> 270°	5	<input checked="" type="checkbox"/> 0.5 kV <input type="checkbox"/> 1 kV	<input checked="" type="checkbox"/> A <input type="checkbox"/> B <input type="checkbox"/> C
L2-N	±	<input checked="" type="checkbox"/> 0° <input checked="" type="checkbox"/> 90° <input checked="" type="checkbox"/> 180° <input checked="" type="checkbox"/> 270°	5	<input checked="" type="checkbox"/> 0.5 kV <input type="checkbox"/> 1 kV	<input checked="" type="checkbox"/> A <input type="checkbox"/> B <input type="checkbox"/> C
L3-N	±	<input checked="" type="checkbox"/> 0° <input checked="" type="checkbox"/> 90° <input checked="" type="checkbox"/> 180° <input checked="" type="checkbox"/> 270°	5	<input checked="" type="checkbox"/> 0.5 kV <input type="checkbox"/> 1 kV	<input checked="" type="checkbox"/> A <input type="checkbox"/> B <input type="checkbox"/> C
L1-GND	±	<input checked="" type="checkbox"/> 0° <input checked="" type="checkbox"/> 90° <input checked="" type="checkbox"/> 180° <input checked="" type="checkbox"/> 270°	5	<input checked="" type="checkbox"/> 1 kV <input type="checkbox"/> 2 kV	<input checked="" type="checkbox"/> A <input type="checkbox"/> B <input type="checkbox"/> C
L2-GND	±	<input checked="" type="checkbox"/> 0° <input checked="" type="checkbox"/> 90° <input checked="" type="checkbox"/> 180° <input checked="" type="checkbox"/> 270°	5	<input checked="" type="checkbox"/> 1 kV <input type="checkbox"/> 2 kV	<input checked="" type="checkbox"/> A <input type="checkbox"/> B <input type="checkbox"/> C
L3-GND	±	<input checked="" type="checkbox"/> 0° <input checked="" type="checkbox"/> 90° <input checked="" type="checkbox"/> 180° <input checked="" type="checkbox"/> 270°	5	<input checked="" type="checkbox"/> 1 kV <input type="checkbox"/> 2 kV	<input checked="" type="checkbox"/> A <input type="checkbox"/> B <input type="checkbox"/> C
N-GND	±	<input checked="" type="checkbox"/> 0° <input checked="" type="checkbox"/> 90° <input checked="" type="checkbox"/> 180° <input checked="" type="checkbox"/> 270°	5	<input checked="" type="checkbox"/> 1 kV <input type="checkbox"/> 2 kV	<input checked="" type="checkbox"/> A <input type="checkbox"/> B <input type="checkbox"/> C
Note: N/A					



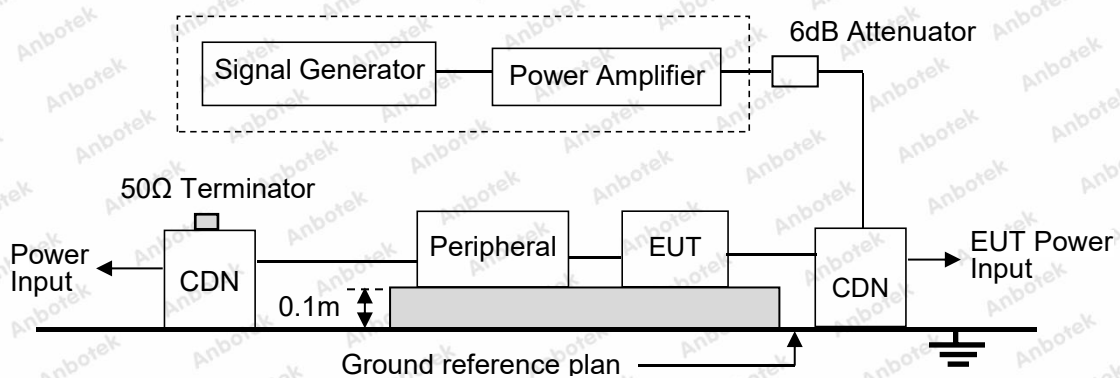
10. Injected Currents Susceptibility Test

10.1. Test Specification

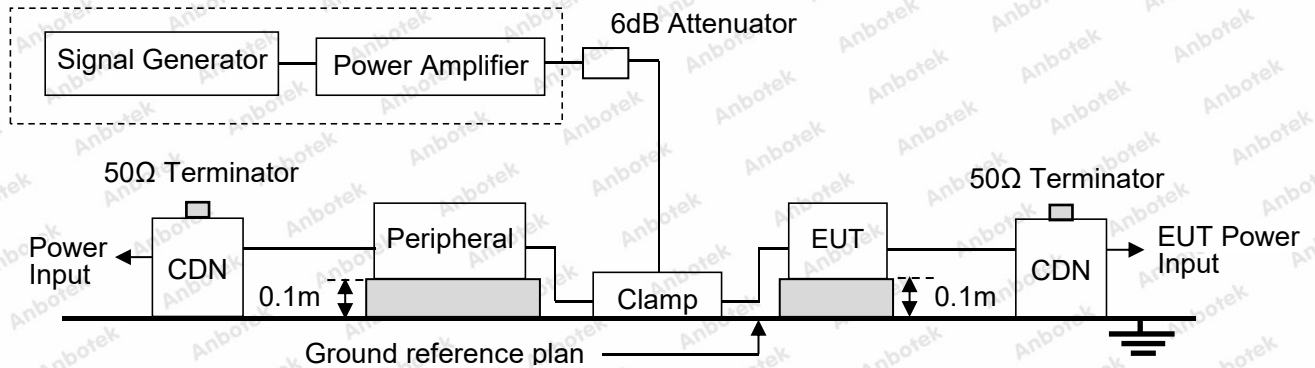
Test Standard:		EN IEC 61326-1
Basic standard:		IEC 61000-4-6: 2013
Performance criteria:		A
Frequency range:		0.15MHz - 80MHz
Test level:	<input checked="" type="checkbox"/> Basic Requirements	3V
	<input type="checkbox"/> Requirements for industrial sites	3V
	<input type="checkbox"/> Requirements for controlled electromagnetic environment	1V
Modulation:		AM 80%, 1kHz sine-wave
Frequency Step:		1% of fundamental

10.2. Test Setup

CDN injection:



Clamp injection:



10.3. Test Procedure

a. The EUT and peripheral are placed on an insulating support of 0.1 m height above a ground reference plan. The distance between EUT and CDN is 0.1 m to 0.3 m. All cables exiting the EUT are supported at a height of at least 30 mm above the ground reference plan.

b. The frequency range is swept from 150 kHz to 80MHz, with the signal 80% amplitude modulated with a 1 kHz sine wave. The rate of sweep did not exceed 1.5×10^{-3} decade/s. The frequency range is swept incrementally. The step size was 1% of fundamental from 0.15MHz to 80MHz.

c. The dwell time at each frequency isn't less than the time necessary for the EUT to be able to respond.

10.4. Test Results

PASS

Please refer to the following page.



Injected Currents Susceptibility Test Results

Test Result:	<input checked="" type="checkbox"/> Pass <input type="checkbox"/> Fail	Temperature:	22.5°C
Power Supply:	AC3*230/400V,50Hz	Humidity:	48%
Frequency Range (MHz)	Injected Position	Voltage (Un-modulated)	Result
<input checked="" type="checkbox"/> Basic Requirements			
0.15 ~ 80	<input checked="" type="checkbox"/> AC Mains <input type="checkbox"/> DC power <input type="checkbox"/> I/O ports	3V	<input checked="" type="checkbox"/> A <input type="checkbox"/> B <input type="checkbox"/> C
<input type="checkbox"/> Requirements for industrial sites			
0.15 ~ 80	<input type="checkbox"/> AC Mains <input type="checkbox"/> DC power <input type="checkbox"/> I/O ports	3V	<input type="checkbox"/> A <input type="checkbox"/> B <input type="checkbox"/> C
<input type="checkbox"/> Requirements for controlled electromagnetic environment			
0.15 ~ 80	<input type="checkbox"/> AC Mains <input type="checkbox"/> DC power <input type="checkbox"/> I/O ports	1V	<input type="checkbox"/> A <input type="checkbox"/> B <input type="checkbox"/> C
Note: N/A			

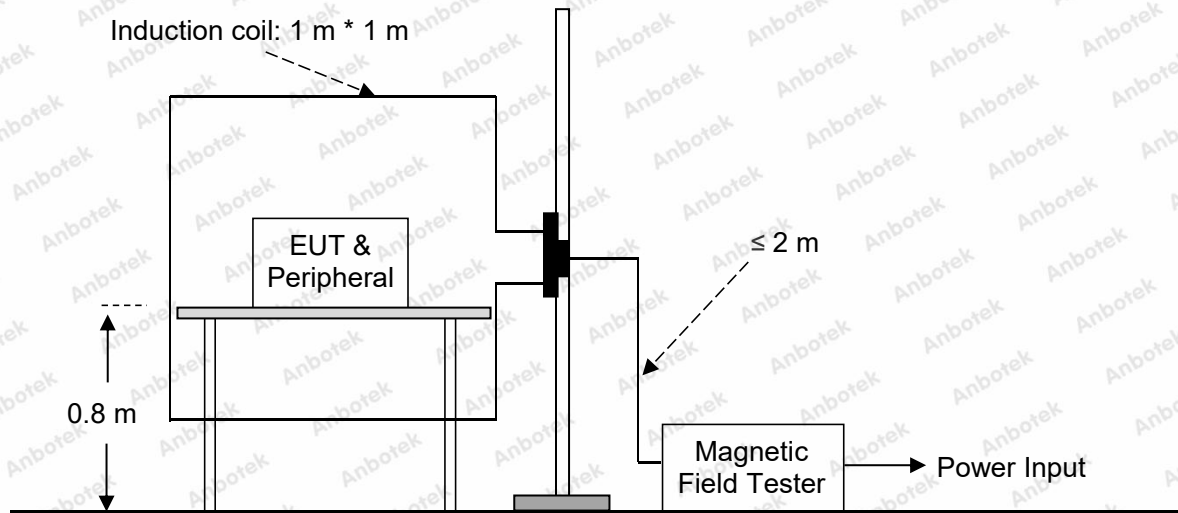


11. Power Frequency Magnetic Field Immunity Test

11.1. Test Specification

Test Standard:	EN IEC 61326-1	
Basic Standard	IEC 61000-4-8: 2009	
Performance criteria	A	
Test level	<input checked="" type="checkbox"/> Basic Requirements	3 A/m
	<input type="checkbox"/> Requirements for industrial sites	30 A/m

11.2. Test Setup



11.3. Test Procedure

Table-top EUT is placed on a table that is 0.8 m height. Floor standing EUT is placed on a ground reference plane and insulated from it by an insulating support with a thickness of 0.1 m.

The EUT is placed in the middle of an induction coil. The proximity method is used when the EUT does not fit into the standard inductive coil

11.4. Test Results

Not applicable.

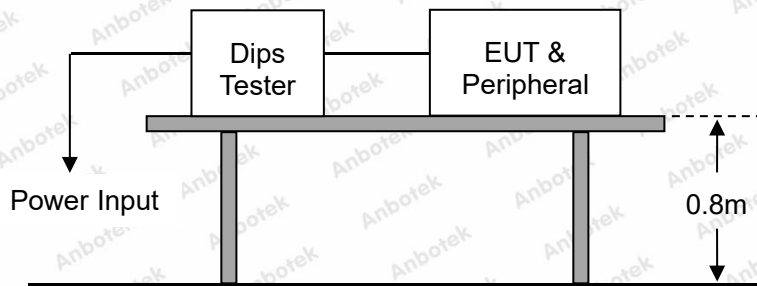


12. Voltage Dips and Interruptions Immunity Test

12.1. Test Specification

Test Standard:	EN IEC 61326-1	
Basic standard:	IEC 61000-4-11: 2020	
Test level:	<input checked="" type="checkbox"/> Basic Requirements	<input checked="" type="checkbox"/> 0%, 0.5 period, Criterion B
		<input checked="" type="checkbox"/> 0%, 1 periods, Criteria B
		<input checked="" type="checkbox"/> 70%, 25 periods, Criteria C
		<input checked="" type="checkbox"/> 0%, 250 periods, Criteria C
	<input type="checkbox"/> Requirements for industrial sites	<input type="checkbox"/> 0%, 1 period, Criterion B
		<input type="checkbox"/> 40%, 10 periods for 50Hz, Criteria C
<input type="checkbox"/> 70%, 25 periods for 50Hz, Criteria C		
		<input type="checkbox"/> 0%, 250 periods for 50Hz, Criteria C

12.2. Test Setup



12.3. Test Procedure

a. Where the equipment has a rated voltage the following shall apply:

- If the voltage range does not exceed 20% of the lower voltage specified for the rated voltage range, a single voltage within that range may be specified as a basis for test level specification.
- In all other cases, the test procedure shall be applied for both the lowest and highest voltages declared in the voltage range.

b. Test Conditions

- Select operated voltage and frequency of EUT - Test of interval: 10 sec.
- Level and duration: Sequence of 3 dips/interrupts.
- Voltage rise (and fall) time: 1.5 μ s.

c. Changes to occur at 0 degree crossover point of the voltage waveform.

12.4. Test Results

PASS

Please refer to the following page.

Shenzhen Anbotek Compliance Laboratory Limited

Address:1/F.,Building D,Sogood Science and Technology Park, Sanwei Community,
Hangcheng Street, Bao'an District, Shenzhen, Guangdong, China.
Tel:(86) 0755-26066440 Fax:(86) 0755-26014772 Email:service@anbotek.com

Code: AB-EMC-02-c



Hotline

400-003-0500

www.anbotek.com.cn



Voltage Dips and Interruptions Test Results

Test Result:	<input checked="" type="checkbox"/> Pass <input type="checkbox"/> Fail	Temperature :	21.1°C
Power Supply :	AC3*230/400V,50Hz	Humidity :	44%
Test Level % UT	Voltage Dips & Short Interruptions % UT	Duration (in periods)	Result
<input checked="" type="checkbox"/> Basic Requirements			
0	100	0.5P	<input checked="" type="checkbox"/> A <input type="checkbox"/> B <input type="checkbox"/> C
0	100	1P	<input checked="" type="checkbox"/> A <input type="checkbox"/> B <input type="checkbox"/> C
70	30	25P	<input checked="" type="checkbox"/> A <input type="checkbox"/> B <input type="checkbox"/> C
<input type="checkbox"/> Requirements for industrial sites			
0	100	1P	<input type="checkbox"/> A <input type="checkbox"/> B <input type="checkbox"/> C
40	60	10P	<input type="checkbox"/> A <input type="checkbox"/> B <input type="checkbox"/> C
70	30	25P	<input type="checkbox"/> A <input type="checkbox"/> B <input type="checkbox"/> C
Test Level % UT	Voltage Dips & Short Interruptions % UT	Duration (in periods)	Result
0	100	250P	<input type="checkbox"/> A <input type="checkbox"/> B <input checked="" type="checkbox"/> C
Note: N/A			



APPENDIX I -- TEST SETUP PHOTOGRAPH

Photo of Power Line Conducted Emission Test

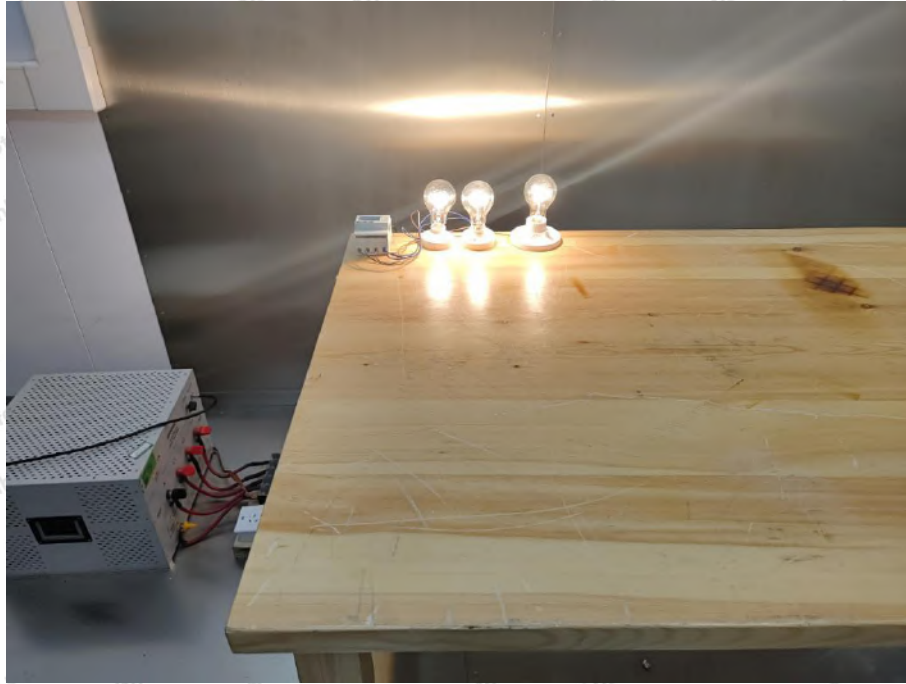


Photo of Radiated Emission Test (Below 1 GHz)

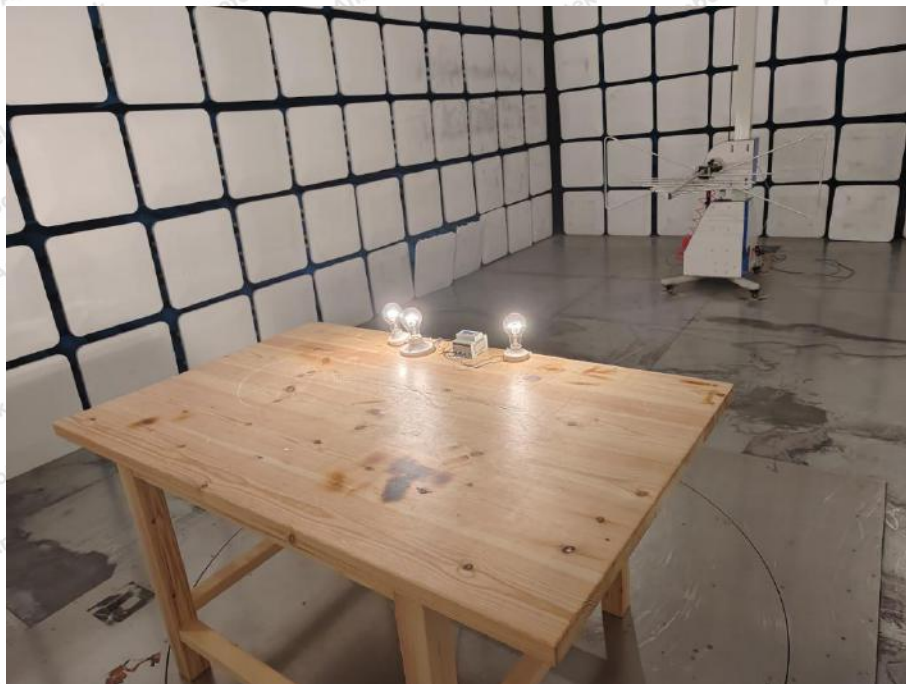


Photo of Electrostatic Discharge Immunity Test



Photo of RF Field Strength Immunity Test

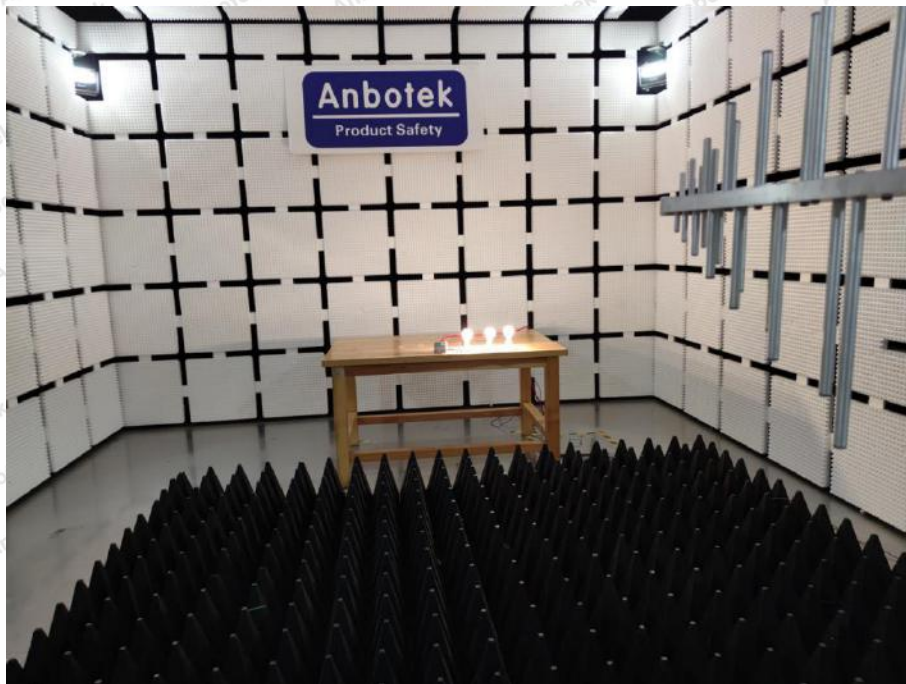


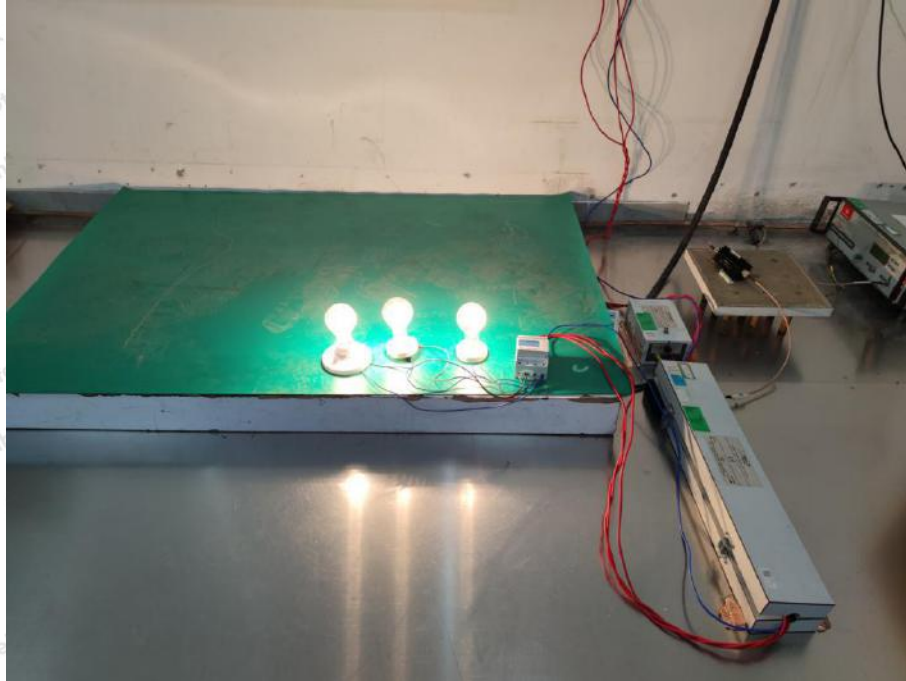
Photo of Electrical Fast Transient/Burst Immunity Test



Photo of Surge Immunity Test

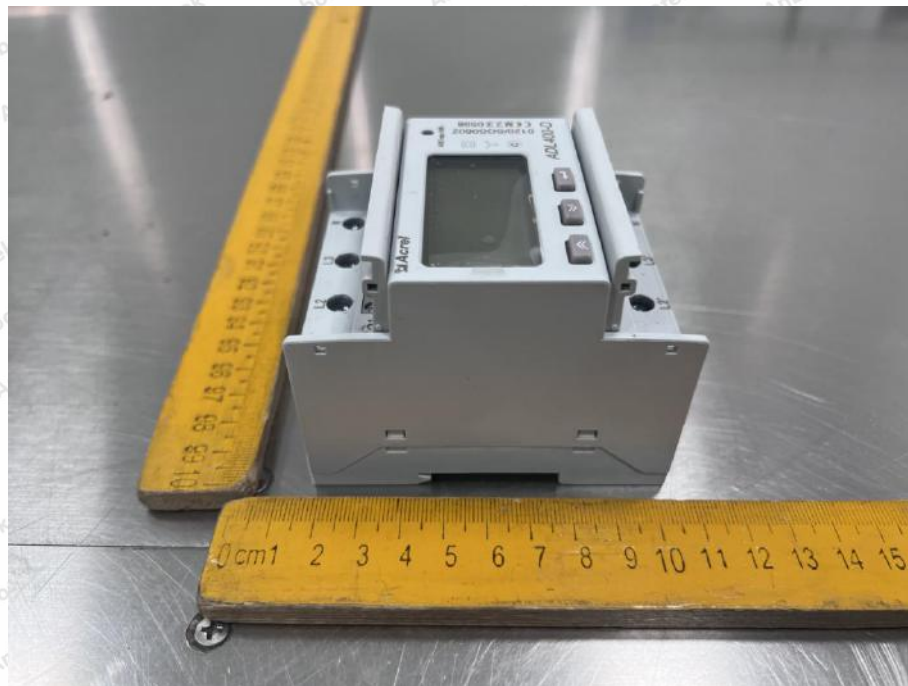
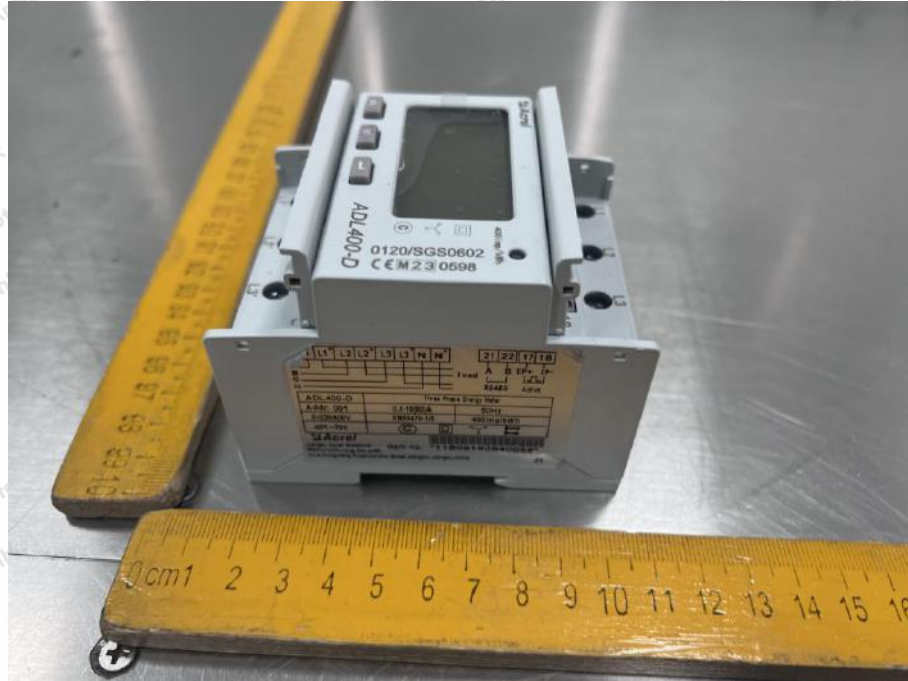


Photo of Injected Currents Susceptibility Test



APPENDIX II -- Photo documentation





CE Label

1. The CE conformity marking must consist of the initials 'CE' taking the following form:

If the CE marking is reduced or enlarged, the proportions given in the above graduated drawing must be respected.

2. The CE marking must have a height of at least 5 mm except where this is not possible on account of the nature of the apparatus.

3. The CE marking must be affixed to the product or to its data plate. Additionally it must be affixed to the packaging, if any, and to the accompanying documents.

4. The CE marking must be affixed visibly, legibly and indelibly.

It must have the same height as the initials 'CE'.

----- End of Report -----

